

**AGREEMENT**

**THIS AGREEMENT** is made and entered into as of this \_\_\_\_ day of \_\_\_\_\_, 2016, by and between

**THE SCHOOL BOARD OF BROWARD COUNTY, FLORIDA**

(hereinafter referred to as “SBBC”),  
a body corporate and political subdivision of the State of Florida,  
whose principal place of business is  
600 Southeast Third Avenue, Fort Lauderdale, Florida 33301

and

**REP SERVICES, INC.**

(hereinafter referred to as “VENDOR ”),  
whose principal place of business is  
581 Technology Park, Suite 1009  
Lake Mary, FL 32746

**WHEREAS**, SBBC desires to obtain goods and services of VENDOR to provide playground equipment, outdoor equipment, surfacing, fitness trails and fabric shade structures; and

**WHEREAS**, SBBC desires to utilize an existing contract between The School District of Palm Beach County, Florida (the “SDPBC”) dated August 19, 2015 and awarded pursuant to ITB 15C-32B Playground Equipment, Outdoor Fitness Equipment, Surfacing, Fitness Trails and Fabric Shade Structures as amended per addendum No.: 1, dated May 20, 2015 as permitted by Rule 6A.1.012(6), Florida Administrative Code and School Board Policy; and

**WHEREAS**, VENDOR and SBBC desire to enter into this Agreement for the use of the ITB for Playground Equipment, Outdoor Fitness Equipment, Surfacing, Fitness Trails and Fabric Shade Structures by and between the SDPBC and VENDOR.

**NOW, THEREFORE**, in consideration of the premises and of the mutual covenants contained herein and other good and valuable consideration, the receipt and sufficiency of which is hereby acknowledged, the Parties hereby agree as follows:

**ARTICLE 1 - RECITALS**

1.01 **Recitals.** The parties agree that the foregoing recitals are true and correct and that such recitals are incorporated herein by reference.

## ARTICLE 2 – SPECIAL CONDITIONS

2.01 **Term of Agreement.** Unless terminated earlier pursuant to Section 3.05 of this Agreement, the term of this Agreement shall **commence from date of award and conclude on July 31, 2018.** The term of the Agreement may, by mutual agreement, be extended for two additional one-year periods and, if needed, 180 days beyond the expiration date of the renewal period. SBBC's Procurement & Warehousing Services Department, will, if considering renewing, request a letter consenting to renewal from VENDOR, prior to the end of the term. Any renewal period shall be approved by an Amendment to this Agreement executed by both parties.

2.02 **Priority of Documents.** The Contract Documents of this Agreement consist of the following documents, in order of priority. In the event of a conflict between the documents, the priority of the documents shall be as follows:

- First: This Agreement,
- Second: The School District of Palm of Beach County Letter of Agreement ("Letter of Agreement"),
- Third: Addendum No. 1,
- Fourth: ITB 15C-32B Playground Equipment, Outdoor Fitness Equipment, Surfacing, Fitness Trails and Fabric Shade Structures (the "ITB"),
- Fifth: Response to the ITB 15C-32B by VENDOR (the "Response to ITB").

2.02.01 The term "The School District of Palm Beach County, Florida" shall be replaced with "The School Board of Broward County, Florida" in all instances where so noted in the attached Letter of Agreement, Addendum No. 1, the ITB and the Response, but which are *not* specifically set forth in this Agreement.

2.02.02 All references to policies of The School District of Palm Beach County, Florida shall be replaced with references to the corresponding and applicable policies of SBBC in all instances where so noted in the attached Letter of Agreement, Addendum No. 1, the ITB and the Response, but which are *not* specifically set forth in the Agreement. **NOTE: It is the responsibility of the VENDOR to request and obtain copies of all such policies of the SBBC.**

2.02.03 The term "School District's Office of Inspector General" shall be replaced with "School Board's Office of the Chief Auditor" in all instances where so noted in the attached Letter of Agreement, Addendum No. 1, the ITB and the Response.

2.03 **Services.** VENDOR shall provide SBBC goods and services, in accordance with the terms, conditions, and specifications of ITB 15C-32B awarded to VENDOR by the SDPBC. **Attachment C**, Letter of Agreement and **Attachment A**, ITB 15C-32B. Goods and services may include the purchase and/or installation of playground equipment at various SBBC school locations.

VENDOR shall not proceed with any work until such time as it receives a fully executed Purchase Order from the SBBC, which shall specifically identify the quantity of materials and/or

work to be provided and/or performed, the location for material delivery or work, the time for provision of such materials and/or work, and the total cost of such materials and/or work.

The materials and/or work identified in the Purchase Order, as well as the place of delivery or performance of such work, shall supersede and replace any such references in the attached Letter of Agreement, Addendum No. 1, the ITB and the Response.

2.04 **Pricing.** SBBC shall pay VENDOR for goods and services rendered under this Agreement in accordance with VENDOR's response to ITB 15C-32B, **Attachment B** and the terms, conditions, and specification of ITB 15C-32B awarded by the SDPBC to VENDOR, **Attachment C**, Letter of Agreement.

VENDOR may offer SBBC a special educational discount for pricing and reduce the cost of purchases during the contract term. VENDOR may invoice SBBC at a lower price than the original bid price submitted in ITB 15C-32B. SBBC may negotiate pricing with VENDOR to receive the best offer.

2.05 **Payment.** SBBC shall pay VENDOR for goods and services as set forth in a fully-executed Purchase Order, and in accordance with the terms, conditions, and specification of ITB 15C-32B awarded to VENDOR by the SDPBC. **Attachment C**

2.06 **Invoices:** Invoices shall be mailed to Physical Plant Operations, 3810 N. W. 10th Avenue, Fort Lauderdale, Florida 33309. However, if the Purchase Order relates to the *School Choice Enhancement Program*, invoices shall be mailed to The Office of Facilities and Construction Management, 3775 SW 16<sup>th</sup> Street, Fort Lauderdale, FL 33312. Delivery copies, packing slips and invoices to SBBC **MUST** include the following to permit SBBC to verify prices with this agreement and expedite the use of material.

- A. Purchase Order number
- B. Complete description of the items
- C. Itemized list prices
- D. Total dollar amount shall be net

2.07 **Inspection of VENDOR's Records by SBBC.** VENDOR shall establish and maintain books, records and documents (including electronic storage media) sufficient to reflect all income and expenditures of funds provided by SBBC under this Agreement. All VENDOR's Records, regardless of the form in which they are kept, shall be open to inspection and subject to audit, inspection, examination, evaluation and/or reproduction, during normal working hours, by SBBC's agent or its authorized representative to permit SBBC to evaluate, analyze and verify the satisfactory performance of the terms and conditions of this Agreement and to evaluate, analyze and verify any and all invoices, billings, payments and/or claims submitted by VENDOR or any of VENDOR's payees pursuant to this Agreement. VENDOR's Records subject to examination shall include, without limitation, those records necessary to evaluate and verify direct and indirect costs (including overhead allocations) as they may apply to costs associated with this Agreement. VENDOR's Records subject to this section shall include any and all documents pertinent to the evaluation, analysis, verification and reconciliation of any and all expenditures under this Agreement without regard to funding sources.

(a) Inspector General Audits. VENDOR shall comply and cooperate immediately with any inspections, reviews, investigations, or audits deemed necessary by the Florida Office of the Inspector General or by any other state or federal officials.

2.08 Notice. When any of the parties desire to give notice to the other, such notice must be in writing, sent by U.S. Mail, postage prepaid, addressed to the party for whom it is intended at the place last specified; the place for giving notice shall remain such until it is changed by written notice in compliance with the provisions of this paragraph. For the present, the Parties designate the following as the respective places for giving notice:

To SBBC:	<b>Superintendent of Schools The School Board of Broward County, Florida 600 Southeast Third Avenue Fort Lauderdale, Florida 33301</b>
With a Copy to:	<b>Director, Physical Plant Operations The School Board of Broward County, Florida 3810 NW 10<sup>th</sup> Avenue Fort Lauderdale, FL 33309</b>
To VENDOR:	<b>John Thomas Almon II, President 581 Technology Park, Suite 1009 Lake Mary, FL 32746</b>

2.09 Background Screening. VENDOR agrees to comply with all requirements of Sections 1012.32 and 1012.465, Florida Statutes, and all of its personnel who (1) are to be permitted access to school grounds when students are present, (2) will have direct contact with students, or (3) have access or control of school funds, will successfully complete the background screening required by the referenced statutes and meet the standards established by the statutes. This background screening will be conducted by SBBC in advance of VENDOR or its personnel providing any services under the conditions described in the previous sentence. VENDOR shall bear the cost of acquiring the background screening required by Section 1012.32, Florida Statutes, and any fee imposed by the Florida Department of Law Enforcement to maintain the fingerprints provided with respect to VENDOR and its personnel. The parties agree that the failure of VENDOR to perform any of the duties described in this section shall constitute a material breach of this Agreement entitling SBBC to terminate immediately with no further responsibilities or duties to perform under this Agreement. VENDOR agrees to indemnify and hold harmless SBBC, its officers and employees from any liability in the form of physical or mental injury, death or property damage resulting from VENDOR's failure to comply with the requirements of this Section or with Sections 1012.32 and 1012.465, Florida Statutes.

### **ARTICLE 3 – GENERAL CONDITIONS**

3.01 No Waiver of Sovereign Immunity. Nothing herein is intended to serve as a waiver of sovereign immunity by any agency or political subdivision to which sovereign immunity may be applicable or of any rights or limits to liability existing under Section 768.28, Florida Statutes. This section shall survive the termination of all performance or obligations under this Agreement and shall be fully binding until such time as any proceeding brought on account of this Agreement is barred by any applicable statute of limitations.

3.02 **No Third Party Beneficiaries.** The parties expressly acknowledge that it is not their intent to create or confer any rights or obligations in or upon any third person or entity under this Agreement. None of the parties intend to directly or substantially benefit a third party by this Agreement. The parties agree that there are no third party beneficiaries to this Agreement and that no third party shall be entitled to assert a claim against any of the parties based upon this Agreement. Nothing herein shall be construed as consent by an agency or political subdivision of the State of Florida to be sued by third parties in any matter arising out of any contract.

3.03 **Independent Contractor.** The parties to this agreement shall at all times be acting in the capacity of independent contractors and not as an officer, employee or agent of one another. Neither party or its respective agents, employees, subcontractors or assignees shall represent to others that it has the authority to bind the other party unless specifically authorized in writing to do so. No right to SBBC retirement, leave benefits or any other benefits of SBBC employees shall exist as a result of the performance of any duties or responsibilities under this Agreement. SBBC shall not be responsible for social security, withholding taxes, contributions to unemployment compensation funds or insurance for the other party or the other party's officers, employees, agents, subcontractors or assignees.

3.04 **Equal Opportunity Provision.** The parties agree that no person shall be subjected to discrimination because of age, race, color, disability, gender identity, gender expression marital status, national origin, religion, sex or sexual orientation in the performance of the parties' respective duties, responsibilities and obligations under this Agreement.

3.05 **Termination.** This Agreement may be canceled with or without cause by SBBC during the term hereof upon thirty (30) days written notice to the other parties of its desire to terminate this Agreement. SBBC shall have no liability for any property left on SBBC's property by any party to this Agreement after the termination of this Agreement. Any party contracting with SBBC under this Agreement agrees that any of its property placed upon SBBC's facilities pursuant to this Agreement shall be removed within ten (10) business days following the termination, conclusion or cancellation of this Agreement and that any such property remaining upon SBBC's facilities after that time shall be deemed to be abandoned, title to such property shall pass to SBBC, and SBBC may use or dispose of such property as SBBC deems fit and appropriate.

3.06 **Default.** The parties agree that, in the event that either party is in default of its obligations under this Agreement, the non-defaulting party shall provide to the defaulting party (30) days written notice to cure the default. However, in the event said default cannot be cured within said thirty (30) day period and the defaulting party is diligently attempting in good faith to cure same, the time period shall be reasonably extended to allow the defaulting party additional cure time. Upon the occurrence of a default that is not cured during the applicable cure period, this Agreement may be terminated by the non-defaulting party upon thirty (30) days notice. This remedy is not intended to be exclusive of any other remedy, and each and every such remedy shall be cumulative and shall be in addition to every other remedy now or hereafter existing at law or in equity or by statute or otherwise. No single or partial exercise by any party of any right, power, or remedy hereunder shall preclude any other or future exercise thereof. Nothing in this section shall be construed to preclude termination for convenience pursuant to Section 3.05.

3.07 **Annual Appropriation.** The performance and obligations of SBBC under this Agreement shall be contingent upon an annual budgetary appropriation by its governing body. If SBBC does not allocate funds for the payment of services or products to be provided under this Agreement, this Agreement may be terminated by SBBC at the end of the period for which funds have been allocated. SBBC shall notify the other party at the earliest possible time before such termination. No penalty shall accrue to SBBC in the event this provision is exercised, and SBBC shall not be obligated or liable for any future payments due or any damages as a result of termination under this section.

3.08 **Excess Funds.** Any party receiving funds paid by SBBC under this Agreement agrees to promptly notify SBBC of any funds erroneously received from SBBC upon the discovery of such erroneous payment or overpayment. Any such excess funds shall be refunded to SBBC with interest calculated from the date of the erroneous payment or overpayment. Interest shall be calculated using the interest rate for judgments under Section 55.03, Florida Statutes, applicable at the time the erroneous payment or overpayment was made by SBBC.

3.09 **Public Records.** Pursuant to Section 119.0701, Florida Statutes, any party contracting with SBBC is required to (a) keep and maintain available for public inspection any records that pertain to services rendered under this Agreement; (b) provide the public with access to public records on the same terms and conditions that SBBC would provide such records and at a cost that does not exceed the cost provided in Chapter 119, Florida Statutes or as otherwise provided by law; (c) ensure that public records that are exempt or confidential and exempt from public records disclosure requirements are not disclosed except as authorized by law; and (d) meet all requirements for retaining public records and transfer, at no cost to SBBC, all public records in that party's possession upon termination of its Agreement with SBBC and destroy any duplicate public records that are exempt or confidential and exempt from public records disclosure requirements. All of such party's records stored electronically must be provided to SBBC in a format that is compatible with SBBC's information technology systems. Each party shall maintain its own respective records and documents associated with this Agreement in accordance with the records retention requirements applicable to public records. Each party shall be responsible for compliance with any public documents request served upon it pursuant to Section 119.07, Florida Statutes, and any resultant award of attorney's fees for non-compliance with that law. Each party acknowledges that this Agreement and all attachments thereto are public records and do not constitute trade secrets.

3.10 **Student Records:** Notwithstanding any provision to the contrary within this Agreement, any party contracting with SBBC under this Agreement shall fully comply with the requirements of Sections 1002.22 and 1002.221, Florida Statutes; FERPA, and any other state or federal law or regulation regarding the confidentiality of student information and records. Each such party agrees, for itself, its officers, employees, agents, representatives, contractors or subcontractors, to fully indemnify and hold harmless SBBC and its officers and employees for any violation of this section, including, without limitation, defending SBBC and its officers and employees against any complaint, administrative or judicial proceeding, payment of any penalty imposed upon SBBC, or payment of any and all costs, damages, judgments or losses incurred by or imposed upon SBBC arising out of a breach of this covenant by the party, or an officer, employee, agent, representative, contractor, or sub-contractor of the party to the extent that the

party or an officer, employee, agent, representative, contractor, or sub-contractor of the party shall either intentionally or negligently violate the provisions of this section or of Sections 1002.22 and/or 1002.221, Florida Statutes.

3.11 **Compliance with Laws.** Each party shall comply with all applicable federal and state laws, codes, rules and regulations in performing its duties, responsibilities and obligations pursuant to this Agreement.

3.12 **Place of Performance.** All obligations of SBBC under the terms of this Agreement are reasonably susceptible of being performed in Broward County, Florida and shall be payable and performable in Broward County, Florida.

3.13 **Governing Law and Venue.** This Agreement shall be interpreted and construed in accordance with and governed by the laws of the State of Florida. Any controversies or legal problems arising out of this Agreement and any action involving the enforcement or interpretation of any rights hereunder shall be submitted to the jurisdiction of the State courts of the Seventeenth Judicial Circuit of Broward County, Florida.

3.14 **Entirety of Agreement.** This document incorporates and includes all prior negotiations, correspondence, conversations, agreements and understandings applicable to the matters contained herein and the parties agree that there are no commitments, agreements or understandings concerning the subject matter of this Agreement that are not contained in this document. Accordingly, the parties agree that no deviation from the terms hereof shall be predicated upon any prior representations or agreements, whether oral or written.

3.15 **Binding Effect.** This Agreement shall be binding upon and inure to the benefit of the parties hereto and their respective successors and assigns.

3.16 **Assignment.** Neither this Agreement or any interest herein may be assigned, transferred or encumbered by any party without the prior written consent of the other party. There shall be no partial assignments of this Agreement including, without limitation, the partial assignment of any right to receive payments from SBBC.

3.17 **Incorporation by Reference.** Exhibits attached hereto and referenced herein shall be deemed to be incorporated into this Agreement by reference.

3.18 **Captions.** The captions, section designations, section numbers, article numbers, titles and headings appearing in this Agreement are inserted only as a matter of convenience, have no substantive meaning, and in no way define, limit, construe or describe the scope or intent of such articles or sections of this Agreement, nor in any way effect this Agreement and shall not be construed to create a conflict with the provisions of this Agreement.

3.19 **Severability.** In the event that any one or more of the sections, paragraphs, sentences, clauses or provisions contained in this Agreement is held by a court of competent jurisdiction to be invalid, illegal, unlawful, unenforceable or void in any respect, such shall not affect the remaining portions of this Agreement and the same shall remain in full force and effect as if such invalid, illegal, unlawful, unenforceable or void sections, paragraphs, sentences, clauses or provisions had never been included herein.

3.20 **Preparation of Agreement.** The parties acknowledge that they have sought and obtained whatever competent advice and counsel as was necessary for them to form a full and complete understanding of all rights and obligations herein and that the preparation of this Agreement has been their joint effort. The language agreed to herein expresses their mutual intent and the resulting document shall not, solely as a matter of judicial construction, be construed more severely against one of the parties than the other.

3.21 **Amendments.** No modification, amendment, or alteration in the terms or conditions contained herein shall be effective unless contained in a written document prepared with the same or similar formality as this Agreement and executed by each party hereto.

3.22 **Waiver.** The parties agree that each requirement, duty and obligation set forth herein is substantial and important to the formation of this Agreement and, therefore, is a material term hereof. Any party's failure to enforce any provision of this Agreement shall not be deemed a waiver of such provision or modification of this Agreement unless the waiver is in writing and signed by the party waiving such provision. A written waiver shall only be effective as to the specific instance for which it is obtained and shall not be deemed a continuing or future waiver.

3.23 **Force Majeure.** Neither party shall be obligated to perform any duty, requirement or obligation under this Agreement if such performance is prevented by fire, hurricane, earthquake, explosion, wars, sabotage, accident, flood, acts of God, strikes, or other labor disputes, riot or civil commotions, or by reason of any other matter or condition beyond the control of either party, and which cannot be overcome by reasonable diligence and without unusual expense ("Force Majeure"). In no event shall a lack of funds on the part of either party be deemed Force Majeure.

3.24 **Survival.** All representations and warranties made herein, indemnification obligations, obligations to reimburse SBBC, obligations to maintain and allow inspection and audit of records and property, obligations to maintain the confidentiality of records, reporting requirements, and obligations to return public funds shall survive the termination of this Agreement.

3.25 **Contract Administration.** SBBC has delegated authority to the Superintendent of Schools or his/her designee to take any actions necessary to implement and administer this Agreement.

3.26. **Liability.** This section shall survive the termination of all performance or obligations under this Agreement and shall be fully binding until such time as any proceeding brought on account of this Agreement is barred by any applicable statute of limitations.

A. By SBBC: SBBC agrees to be fully responsible up to the limits of Section 768.28, Florida Statutes, for its acts of negligence, or its employees' acts of negligence when acting within the scope of their employment and agrees to be liable for any damages resulting from said negligence.

B. By VENDOR: VENDOR agrees to indemnify, hold harmless and defend SBBC, its agents, servants and employees from any and all claims, judgments, costs, and expenses

including, but not limited to, reasonable attorney's fees, reasonable investigative and discovery costs, court costs and all other sums which SBBC, its agents, servants and employees may pay or become obligated to pay on account of any, all and every claim or demand, or assertion of liability, or any claim or action founded thereon, arising or alleged to have arisen out of the products, goods or services furnished by VENDOR, its agents, servants or employees; the equipment of VENDOR, its agents, servants or employees while such equipment is on premises owned or controlled by SBBC; or the negligence of VENDOR or the negligence of VENDOR's agents when acting within the scope of their employment, whether such claims, judgments, costs and expenses be for damages, damage to property including SBBC's property, and injury or death of any person whether employed by VENDOR, SBBC or otherwise.

3.27 **Travel.** Local travel shall not be billed as a reimbursable expense. Out of county travel and per diem may be allowable at the sole discretion of SBBC. SBBC has delegated authority to the Superintendent of Schools or his/her designee to provide prior approval to VENDOR for any and all travel and per diem. Should any out of county travel and/or per diem be allowed, then it shall be billed and reimbursed in compliance with the current or updated School Board Policy 3400 and/or other relevant School Board Policies.

3.28 **School Board Policies.** VENDOR agrees to comply with all School Board Policies, local, state and federal laws.

3.29 **Authority.** Each person signing this Agreement on behalf of either party individually warrants that he or she has full legal power to execute this Agreement on behalf of the party for whom he or she is signing, and to bind and obligate such party with respect to all provisions contained in this Agreement.

**IN WITNESS WHEREOF**, the Parties hereto have made and executed this Agreement on the date first above written.

**FOR SBBC**

(Corporate Seal)

THE SCHOOL BOARD OF BROWARD  
COUNTY, FLORIDA

By \_\_\_\_\_  
Dr. Rosalind Osgood, Chair

ATTEST:

\_\_\_\_\_  
Robert W. Runcie, Superintendent of Schools

Approved as to Form and Legal Content:  
  
\_\_\_\_\_  
Office of the General Counsel

**FOR VENDOR**

(Corporate Seal)

REP SERVICES, INC.

ATTEST:

By John T. Almon II  
John T. Almon II  
President

\_\_\_\_\_, Secretary

-or-

Joe Holther

Witness

Patricia Thomas

Witness

**The Following Notarization is Required for Every Agreement Without Regard to Whether the Party Chose to Use a Secretary's Attestation or Two (2) Witnesses.**

STATE OF Florida

COUNTY OF Sevinde

The foregoing instrument was acknowledged before me this 2nd day of June, 2014 by John T. Almon II of Rep Services, Inc on behalf of the corporation/agency.

He/She is personally known to me or produced \_\_\_\_\_ as identification and did/did not first take an oath. \_\_\_\_\_ Type of Identification

My Commission Expires: May 8, 2018

JF Rohrborn  
Signature - Notary Public

JF Rohrborn  
Printed Name of Notary

#FF 121405  
Notary's Commission No.

(SEAL)

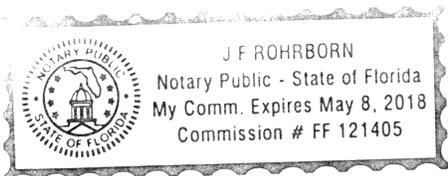

**School District of Palm Beach County FL**



**Invitation to Bid No.  
15C-32B**

**Playground Equipment, Outdoor Fitness Equipment, Surfacing, Fitness Trails and Fabric  
Shade Structures**

.....

**RESPONSES ARE DUE PRIOR TO:**

**2:00 PM (EST), May 27, 2015**

.....

**RESPONSES MUST BE SUBMITTED ELECTRONICALLY TO:**

[www.Demandstar.com](http://www.Demandstar.com)

.....

The School District of Palm Beach County is an  
Equal Education Opportunity Provider and Employer.  
[http://www.palmbeachschools.org/purchasing/documents/Equity Coordinators.pdf](http://www.palmbeachschools.org/purchasing/documents/Equity_Coordinators.pdf)

**15C-32B - SPECIAL CONDITIONS**

**A. SCOPE:** The purpose and intent of this Invitation to Bid is to secure prices and establish a Term Contract to Furnish and Install Playground Equipment, Outdoor Fitness Equipment, Surfacing, Fitness Trails and Fabric Shade Structures, as specified herein.

**B. DELIVERY:** Items in the Invitation to Bid are for various schools and departments located throughout Palm Beach County and are not for delivery to any central location. Awarded vendors for equipment are responsible for supplying all labor, materials, and equipment required for the off-loading and placement of items as directed, at all delivery locations, without assistance of School District personnel. A minimum of 48 hours advance notification of delivery is required from all freight carriers to the District's designated staff.

**C. DEMANDSTAR:**

1. All offers must be submitted electronically to Demandstar.com.
2. DemandStar requires that all documents be downloaded, completed, saved and re-uploaded to submit your offer. DemandStar does not support online document completion.
3. The Vendor Contact Information page on the DemandStar site has a required field "BID AMOUNT". The District does not require this field to be completed, but in order to complete the process DemandStar requires input. It is suggested that you input zero. All the District requirements should be included in number one above.
4. It is recommended that you incorporate your response into one document or as few separate uploads as possible when submitting your offer to DemandStar.
5. **The District will only consider offers that have been uploaded and submitted prior to the bid closing date and time. Allow sufficient time to complete your offer.**
6. **IMPORTANT INFORMATION:** When finished uploading all required documents, at the end of the document, **you must Submit your Response.**

After clicking "Submit Response" the following process will begin:

- DemandStar will verify that your response is complete as entered.
- You will see a confirmation page with your confirmation number and date/time stamp of your upload.
- You will receive a confirmation e-mail indicating a successful response submittal.

**If you do not receive any of the above, please call DemandStar Supplier Services at (800)711-1712 or email [demandstar@onvia.com](mailto:demandstar@onvia.com)**

**For additional information please go to:**

<http://www.palmbeachschools.org/purchasing/bids/purch/vendor/ebidding.pdf>

7. Hard copy bids will not be accepted.
8. Be advised that DemandStar has a limit of 30MB per document upload and a 100MB maximum per vendor response.

If necessary, an addendum will be distributed by DemandStar to all who are known by the Purchasing Department to have received a complete set of proposal documents.

- D. BENEFICIAL INTEREST AND DISCLOSURE OF OWNERSHIP AFFIDAVIT:** The School District is requesting this affidavit to include a list of every “person” (as defined in Section 1.01 (3), Florida Statutes to include individuals, children, firms, associates, joint adventures, partnerships, estates, trusts, business trusts, syndicates, fiduciaries, corporations and all other groups and combinations) holding 5% or more of the beneficial interest in the disclosing entity. **The Beneficial Interest and Disclosure of Ownership Affidavit (PBSD Form 1997) must be completed, signed, notarized and returned with your bid.**
- E. FLORIDA PREFERENCE:** Pursuant to §287.084 Florida Statute, award recommendations shall make appropriate adjustments to pricing when considering solicitations from Proposers having a principal place of business outside the State of Florida. **All Proposers must complete and submit the attached Proposers Statement of Principal Place of Business with the response to this solicitation.** Failure to comply may be considered non-responsive to the terms of this solicitation. Refer to <http://www.leg.state.fl.us/Statutes/index.cfm> for additional information regarding this Statute.
- F. M/WBE PREFERENCE:** Pursuant to Board Policy 6.143, award recommendations shall make appropriate adjustments to pricing when considering solicitations from a State of Florida or District certified Minority/Women Business Enterprise (M/WBE) if the bid price does not exceed the lowest bidder's price by an amount greater than \$50,000 or 5%, whichever is less. In instances where the certified M/WBE's price difference is greater than \$50,000 or 5%, the lowest responsive, responsible bidder will be awarded the contract and the goals shall be deemed waived. The requirements to qualify for the M/WBE are to be certified either by the State of Florida or the School District of Palm Beach County, **subject to the criteria indicated in paragraph P.** The District does not recognize any other certifications. Graduation (as described in Board Policy 6.143) from the District M/WBE Certification Program shall void certification by the State of Florida, if a vendor has exceeded the revenue/sales size standards for their industry specific classification for the previous three year period. **See Paragraph N, M/WBE GOAL for complete detail.** For District certification go to <http://www.palmbeachschools.org/MWBE> website and complete the M/WBE certification application.
- G. AWARD:** In order to meet the needs of the District, awards shall be made to all bidders found to be responsive and responsible and who offer a firm percentage discount for equipment, submit catalogs, agree to provide quotes as requested, and otherwise comply with all bid specifications, terms and conditions contained herein, including identifying their certified installer. That installer must respond to this bid. If the certified installer is found to be responsive and responsible and agrees to comply with all bid specifications and terms and conditions pertaining to installation and contained herein, the installer will be awarded on this bid. If the certified installer identified by the vendor responding only to the firm percentage discount for equipment section of this bid is not awarded, the vendor offering only discounts on equipment may be rejected.
- H. TERM OF CONTRACT:** The term of this contract shall be from August 20, 2015 through August 19, 2020. The contract may be extended ninety (90) days beyond the contract expiration date, if needed. The awardee agrees to this condition by signing their bid. The awardee will be notified by the Purchasing Department when the recommendation has been acted upon. All discount percentages and prices shall be firm for the term of this contract; however, nothing prohibits the District from accepting lower pricing during the term of this contract.

- I. REFERENCES:** Complete the Reference Document and include at least five (5) references from customers that you have contracted with to provide and/or install playground or outdoor fitness equipment, PIP surfacing, artificial turf, fabric shade structures or fitness trails

NOTE: The information requested must include a current contact name, and email address for each reference.

- J. QUALIFICATIONS:** Provide photocopies of the following (**valid and current**) licenses and/or certificates: **Failure to provide this documentation may result in rejection of bid.** Palm Beach County Local Business Tax Receipt, formerly Occupational License.

The bidder(s) must have an adequate organization, facilities, equipment, and personnel to insure prompt and efficient service. The District reserves the right, before recommending any award, to inspect the facilities to determine ability to perform. The District reserves the right to reject bids where evidence submitted, investigation and/or evaluation, is determined to indicate inability of the bidder to perform.

- K. PLACING AN OFFER:** All offers must be submitted electronically to Demandstar.com. No offer will be considered if submitted after the closing date and time. Hard copy bids will not be accepted.

Allow sufficient time to complete your offer, **and follow all steps outlined in Paragraph C.**

If necessary, an addendum will be distributed by DemandStar to all who are known by the Purchasing Department to have received a complete set of proposal documents.

- L. BID QUESTIONS:** Any questions concerning conditions and specifications must be submitted by email to Karen L. Adducci at [Karen.Adducci@palmbeachschools.org](mailto:Karen.Adducci@palmbeachschools.org) no later than 5:00 p.m. EST, on May 15, 2015. Questions received in writing by the time and date specified will be answered in writing and posted on DemandStar. Mrs. Adducci is authorized only to direct the attention of prospective proposers to various portions of the Bid so that they may read and interpret such for themselves. Neither Mrs. Adducci nor any employee of the District is authorized to interpret any portion of this Bid or give information as to the requirements of the Bid in addition to that contained in the written documents.

All questions submitted (along with their source) are subject to Public Records Laws and as such will be available for inspection upon receipt of a Public Records Request.

- M. POSTING OF BID RECOMMENDATION / TABULATIONS:** Bid recommendations and tabulations will be posted electronically with DemandStar and at the Fulton Holland Educational Services Center Purchasing Department, at 3300 Forest Hill Boulevard, Third Floor, A-Wing Suite A-323 West Palm Beach, FL, for review by interested parties, on June 11, 2015, at 3:00 p.m., EST, and will remain posted for a period of 72 hours. If the bid tabulation with recommended awards is not posted by said date and time, A "Notice of Delay of Posting" will be posted to inform all bidders of the new posting date and time.

Any person adversely affected by the decision or intended decision, as defined in School Board Policy 6.14 (4) (a), must file a notice of protest, in writing, within 72 hours after the posting of the notice of decision or intended decision. Saturdays, Sundays and State Holidays shall be excluded in the computation of the 72-hour time period. The formal written protest must be filed within 10 days after the date the notice of protest is filed. The formal written protest shall state with particularity the facts and law upon which the protest is based. Failure to file a notice of protest or to file a formal written protest within the time prescribed in section 120.57 (3), Florida Statutes, shall constitute a waiver of proceedings under chapter 120, Florida Statutes.

- N. M/WBE GOAL:** The Goal Setting Committee has established a 5% bid preference for participation/utilization of Minority/Women's Business Enterprises.

The Board strongly encourages the use of Minority/Woman Owned Business Enterprises for participation as partners, joint-venturers, prime contractor, sub-contractors, and in contracting opportunities. Listings of District Certified Minority and Women Business Enterprises can be found on the District's Office of Diversity in Business Practices web site at <http://www.palmbeachschools.org/mwbe/>.

- O. SUB-CONTRACTING:** If a vendor intends to sub-contract any portion of this bid for any reason, the name and address of the subcontracting firm must be submitted with the bid or prior to use for approval. No sub-contracting will take place prior to bid-awarded vendor furnishing this information and receiving written approval from the District. Subcontractors will be required to conform to the Jessica Lunsford Act as noted in the Instructions to Bidders document of this bid.

The Purchasing Department reserves the right to reject a subcontractor who previously failed in the proper performance of an award or failed to deliver on-time contracts of a similar nature, or who is not in the position to perform this award. The School District Representative reserves the right to inspect all facilities of any subcontractor in order to make determination as to the foregoing. The subcontractor will be equally responsible for meeting all requirements specified in this Invitation to Bid. Vendors are encouraged to seek minority and women business enterprises for participation in sub-contracting opportunities. The sub-contractor shall be equally responsible for meeting all requirements specified in this Invitation to Bid.

- P. MINORITY BUSINESS PARTICIPATION:**

Bidders who list minority subcontractors as participants in their bids will complete the M/WBE SUBCONTRACTOR PARTICIPATION LETTER OF INTENT (FORM 1525) and M/WBE SUBCONTRACTOR PARTICIPATION SUMMARY (FORM 1526). The summary (FORM 1526) will be submitted with all requests for payment.

The District only recognizes as acceptable for certification as minority/woman business enterprises those firms, vendors, and consultants that have successfully completed the certification requirements of the State of Florida Office of Supplier Diversity or the School District of Palm Beach County's Office of Diversity in Business Practices. The letter or certificate will only be deemed valid if the dates for certification have not expired. Any pending application with the District or the State of Florida Office of Supplier Diversity shall not be considered as certification of the vendor making application for consideration as a M/WBE firm.

In order to receive consideration for M/WBE participation, the bidder or firm(s) to be utilized by the bidder must be certified by the District or the State of Florida at the time that the bid is opened.

The District does not currently by implication or direct means have reciprocity with any governmental or non-governmental entity, with the exception of the State of Florida Office of Supplier Diversity for the purpose of sharing and/or acceptance of M/WBE vendors, consultants, for certification. The District does not recognize any other certifications.

Graduation (as described in School Board of Palm Beach County Policy 6.143) from the School District M/WBE Certification shall void certification by the State of Florida. Certification shall be verified and point award shall be determined by the Office of Diversity in Business Practices.

**Industry Specific Classifications:**

To ensure compliance with program guidelines and intent, proposers/subcontractors presenting State of Florida certification will receive MWBE bid preference ONLY if their specific MWBE classification is consistent with, and meets the standards identified in the Industry Specific Classifications and thresholds contained in School Board Policy 6.143 and the Office of Diversity in Business Practices' Procedures Manual.

**The industry specific classification for this solicitation is:**

- General Procurement- Asian and Native American owned

**Revenue/ Sales Size Standards for Industry Specific Classifications:**

Any firm that has exceeded gross sales or revenues (averaged over the last three (3) years) greater than the amounts below shall not be considered eligible to participate in the School District's M/WBE program.

- \$3,000,000 (Three Million dollars) for General Procurement

**To verify eligibility of State of Florida M/WBE Certified Vendors:** Bidders shall include in their bid response notarized copies of the front page of their or their subcontractor's tax return for the previous three years. **Failure to do so will result in denial of M/WBE bid preference for utilization of State of Florida certified M/WBE bidders/subcontractors.**

**Q. ACCESSIBILITY TO AND COOPERATION WITH INSPECTOR GENERAL AND STAFF:**

The Awarded Vendor agrees and understands that the School District's Office of Inspector General shall have immediate, complete, and unrestricted access to all financial and performance-related records, papers, books, documents, information, writings, drawings, graphs, photographs, processes, data or data compilations, computer hard drives, emails, instant messages, services, and property or equipment purchased in whole or in part with School Board funds ("Information and Records"). The Awarded Vendor shall furnish the Inspector General with all Information and Records requested for the purpose of conducting an investigation or audit, as well as provide the Inspector General with reasonable assistance in locating assets and obtaining Information and Records that are in the possession, custody, or control of the Awarded Vendor or its subcontractor. The Awarded Vendor understands, acknowledges, and agrees to abide by applicable portions of School Board Policy 1.092. Such policy is located at: <http://www.palmbeachschools.org/policies/>.

**R. PUBLIC RECORDS LAW**

The Contractor will be required by contract to:

- 1) Keep and maintain public records that ordinarily and necessarily would be required by the public agency in order to perform the service.
- 2) Provide the public with access to public records on the same terms and conditions that the public agency would provide the records and at a cost that does not exceed the cost provided in this chapter or as otherwise provided by law.
- 3) Ensure that public records that are exempt or confidential and exempt from public records disclosure requirements are not disclosed except as authorized by law.
- 4) Meet all requirements for retaining public records and transfer, at no cost, to the public agency all public records in possession of the contractor upon termination of the contract and destroy any duplicate public records that are exempt or confidential and exempt from public records disclosure requirements. All records stored electronically must be provided to the public agency in a format that is compatible with the information technology systems of the public agency.

**Public Records Exemption:**

- 1) For purposes of this paragraph, “competitive solicitation” means the process of requesting and receiving sealed bids, proposals, or replies in accordance with the terms of a competitive process, regardless of the method of procurement.
- 2) Sealed bids, proposals, or replies received by an agency pursuant to a competitive solicitation are exempt from s. 119.07(1) and s. 24(a), Art. I of the State Constitution until such time as the agency provides notice of an intended decision or until 30 days after opening the bids, proposals, or final replies, whichever is earlier.
- 3) If an agency rejects all bids, proposals, or replies submitted in response to a competitive solicitation and the agency concurrently provides notice of its intent to reissue the competitive solicitation, the rejected bids, proposals, or replies remain exempt from s. 119.07(1) and s. 24(a), Art. I of the State Constitution until such time as the agency provides notice of an intended decision concerning the reissued competitive solicitation or until the agency withdraws the reissued competitive solicitation. A bid, proposal, or reply is not exempt for longer than 12 months after the initial agency notice rejecting all bids, proposals, or replies.

**S. INSURANCE REQUIREMENTS:** Proof of the following insurance will be furnished by the awarded vendor(s) to the School Board of Palm Beach County by Certificate of Insurance.

Original copies of Certificates of Insurance meeting the specific required provision specified within this contract/agreement shall be forwarded to the School District of Palm Beach County, Purchasing Department by email ([insurancecertificate@palmbeachschools.org](mailto:insurancecertificate@palmbeachschools.org)), or fax (561-963-3823), and approved prior to the start of any work or the possession of any school property. Renewal certificates must be forwarded to the same department prior to the policy renewal date.

Thirty days written notice must be provided to the School District of Palm Beach County via certified mail in the event of cancellation. The notice must be sent to the Purchasing Department.

The awarded vendors shall provide complete copies of any insurance policy for required coverage within seven days of the date of request by the Purchasing Department. For all contracts with an amount of \$500,000 or more the actual INSURANCE POLICY must be included with the Certificate of Insurance.

1. **WORKERS' COMPENSATION:** Bidder(s) must comply with FSS 440, Workers' Compensation and Employees' Liability Insurance with minimum statutory limits.
2. **COMMERCIAL GENERAL LIABILITY:** Awarded vendors shall procure and maintain, for the life of this contract/agreement, Commercial General Liability Insurance. This policy shall provide coverage for death, bodily injury, personal injury, products and completed operations liability and property damage that could arise directly or indirectly from the performance of this agreement. It must be an occurrence form policy. **THE SCHOOL BOARD OF PALM BEACH COUNTY SHALL BE NAMED AS AN ADDITIONAL INSURED ON THE CERTIFICATE FOR COMMERCIAL GENERAL LIABILITY INSURANCE.**

The minimum limits of coverage shall be \$1,000,000 per occurrence, Combined, Single Limit for Bodily Injury Liability and Property Damage Liability.

3. **BUSINESS AUTOMOBILE LIABILITY:** Awarded vendors shall procure and maintain, for the life of the contract/agreement, Business Automobile Liability Insurance. **THE SCHOOL BOARD OF PALM BEACH COUNTY SHALL BE NAMED AS AN ADDITIONAL INSURED ON THE CERTIFICATE FOR BUSINESS AUTOMOBILE LIABILITY INSURANCE.**

The minimum limits of coverage shall be \$1,000,000 per occurrence. This coverage shall be an "Any Auto" form policy or a form policy that includes "Scheduled Autos, Hired Autos, and Non-Owned Autos" coverage. The insurance must be an occurrence form policy.

In the event the contractor does not own any vehicles, we require an affidavit signed by the contractor indicating the following:

\_\_\_\_\_ (Company Name) does not own any vehicles. In the event we acquire any vehicles throughout the term of this contract/agreement, \_\_\_\_\_ (Company Name) agrees to purchase Business Automobile Liability coverage as indicated above on the date of acquisition.

4. **WAIVER OF SUBROGATION:** In the event of loss, damage or injury to the awarded bidder(s) and/or the awarded bidder's property, the awarded bidder(s) shall look solely to any insurance in its favor without making any claim against the School Board of Palm Beach County. The awarded bidder(s) hereby waives any right of subrogation against the School Board of Palm Beach County, for loss, damage or injury within the scope of the Performer's insurance, and on behalf of itself and its insurer, waives all such claims against the School Board of Palm Beach County.

NOTE: The terms and conditions of this agreement shall apply with respect to awarded bidder's operations for any school or ancillary owned by the School Board of Palm Beach County.

- I. PAYMENT / PAYMENT TERMS:** Payment will be made after the goods/services from the awarded vendor have been received/completed; inspected and found to comply with award specifications, free of damage or defect; and a properly billed invoice is received and processed in the Accounting Services Department.

The District's payment terms are net 30 days; however, the District will accept terms for early payment. See **Early Payment Terms Document**.

**Payment will not be processed until the following occurs:**

1. The complete and satisfactory receipt of all items ordered. All pricing in accordance with the bid.
2. The receipt of a properly billed invoice in the Accounting Services Department.

**Invoices to the School Board MUST include the following to permit verification of prices and expedite payment to vendors:**

1. Name and Address of Vendor
2. A Unique Invoice Number
3. Date of Shipment
4. Line Item Total or Extended Price
5. Purchase Order Number
6. A copy of the first invoice for this contract shall be sent to the Purchasing Agent for review at [karen.adducci@palmbeachschools.org](mailto:karen.adducci@palmbeachschools.org)

**Invoice copy and/or packing slip must be presented at time of delivery. Original Invoice must be sent to Accounting Services, 3300 Forest Hill Blvd., Suite A-323, West Palm Beach, FL 33406, or submitted electronically.**

To submit an invoice as an email attachment, ensure that the electronic document meets the guidelines below and email the invoice to [apinvoice@palmbeachschools.org](mailto:apinvoice@palmbeachschools.org). That's it. Instead of waiting a few days for us to receive your invoice, we can start processing it as soon as we receive it.

**Electronic Invoice Submission Guidelines:**

- a. Submit industry standard PDF's, created at a 300-dpi bi-tonal equivalent (either image or text only content) or bi-tonal or grey scale TIF's.
- b. Each invoice must be its own file attachment. Multiple invoices in a single email is supported, but each invoice must be a separate file attachment

If you are interested in learning more about submitting invoices via email, please contact Bob Rucinski at [bob.rucinski@palmbeachschools.org](mailto:bob.rucinski@palmbeachschools.org), or call him at (561) 434-8701.

**Failure to timely submit invoices(s) to Accounting Services as set forth above may significantly delay processing and payment of the invoice.**

**The School Board may not process invoices submitted more than 120 Days after the date the goods or services were delivered without prior approval from the Accounting Services Department.**

**Vendor waives claims for payment of goods and/or services on invoice(s) not received by the Accounting Services Department within 120 Days of the delivery. Prior approval by Accounting Services is required if invoicing will extend past 120 days.**

**The above terms and conditions are agreed to by submitting an offer on this bid.**

- U. INCORRECT PRICING/INVOICES:** Any pricing on invoices that is incorrect or freight charges that were not included on the original Purchase Order, must be brought to the attention of the Purchasing Agent and corrected prior to the shipment(s) of goods or initiation of services. Additional costs that were not brought to the District's attention and did not receive written approval via a Change Order issued by the Purchasing Agent may not be honored.
- V. CHANGE ORDERS:** Any addition(s) to the Scope of Work or to a Purchase Order as a result of the bid award that adds additional costs must be brought to the School Districts attention and approved by the Purchasing Department prior to commencement of additional work, shipment of goods or the addition of unauthorized freight charges. Once approved, a Change Order will be issued to include the additional costs and work may commence and/or shipment of goods can begin. Additional costs that were not brought to the district's attention and did not result in a Change Order approved by the Purchasing Agent may not be honored.
- W. DISTRICT PURCHASING CARD:** The School District has authorized the use of a Purchasing Card with Visa through the Bank of America to expedite small dollar purchases for materials, supplies, and other items needed for daily operations. Vendors may be presented these credit cards by authorized School District personnel for the above mentioned purchases. Each cardholder's authorization limit may not exceed \$1,000 daily per vendor effective July 1, 2006 (with the exception of travel). Purchase orders are strongly discouraged for purchasing materials, and supplies under \$1,000.
- X. ORGANIZATION PROFILE:** Provide the Corporate Name and Parent Company (if applicable) and address of corporate headquarters. Provide the names, titles, addresses, email and telephone numbers of the persons authorized to answer any questions related to Company's proposal. The Organization Profile should also include information such as number of years in the business, number of locations, location of facilities, company vision statement and a succinct history of the company. In addition the Beneficial Interest and Disclosure of Ownership Affidavit (PBSD Form 1997) must be completed, signed, notarized and returned with your bid.
- Y. COMPANY FINANCIALS:** Vendors must provide financial statements giving the District enough information to determine financial stability. These statements may include, but are not limited to:
- a. Balance Sheet or Annual Report for the last three (3) years
  - b. Three (3) years of income statements and related earnings
  - c. Statement of Changes in financial position
  - d. Letter from the proposer banking institution
  - e. Statement from certified public accounting firm

**Z. ESTIMATED DOLLAR VALUE:** No guarantee of the dollar amount of this bid is implied or given.

**AA. WARRANTY:** Supplier/installer shall guarantee entire installed system to be free of defects in workmanship and materials for no less than one year from date installation is accepted. Supplier and/or installer shall repair and/or replace, at no cost to the School District, any defects or malfunctions noted during the warranty period and shall in addition transfer any manufacturer's guarantee for supplier/installer furnished equipment extending beyond this contract period to the owner. Supplier shall provide the manufacturer's warranty in writing and certified to the District's designee upon final inspection.

**BB. SALES PROMOTION / PRICE REDUCTION:** It is understood that sales promotions occur during the course of this contract that will lower prices of products for the period of the sales promotion. The District shall receive the full benefit of such reductions if lower than the discount established by this bid. The Purchasing Department must be notified of these promotions in writing, specifying the beginning and ending dates of the sales promotion.

Successful bidder(s) may always offer the District an additional discount at any time and invoice the District at a lower cost. Price reductions announced by the vendor shall take effect immediately and be applied to unshipped and subsequent orders.

**CC. HOURS OF OPERATION:** The installer is advised that the normal installation of these units shall occur when school is in session. It shall be the installer's responsibility to perform necessary measures, which may include erection of barricades and signs to isolate their work site and minimize the possibility of injury to staff and students. Additionally, it shall be the responsibility of the contractor to secure the area to protect their equipment and tools as well as to protect surfacing or foundation after it is poured and the playground components until the final inspection and acceptance by the District. There shall be no cost to the District for these safety and security measures.

**BID PREPARATION CHECKLIST:** The Bid Preparation Checklist is a guide to assist the Bidder in verifying the completeness of their Bid. The Bid Preparation Checklist does not relieve the Bidder of the responsibility of ensuring that all requirements of this solicitation are included with submittal of their response. Items checked "required" must be submitted with your bid response or your bid may be declared non responsive.

Verified by Vendor	Required	Document	See Special Condition
	Yes	Bidder Acknowledgement	N/A
	Yes	Bid Summary Document	N/A
	Yes	Certificates/License	Paragraph J
	Yes	Beneficial Interest and Disclosure of Ownership Affidavit	Paragraph D
	Yes	Proposer's Statement of Principal Place of Business	Paragraph E
	Yes	Debarment Certification	N/A
	Yes	Reference Document	Paragraph I
	Yes (if applicable)	Form 1525, Letter of Intent – M/WBE Subcontractor Participation	Paragraph P
	Yes (if applicable)	Form 1526, M/WBE Subcontractor Participation Summary	Paragraph P
	Yes	Form 0580, Drug-Free Workplace Certification	N/A
	Yes	Organizational Profile	Paragraph X
	Yes	Company Financials	Paragraph Y

## **INSTRUCTIONS TO BIDDERS**

The General Conditions for Bids, Instructions to Bidders, Special Conditions, Specifications, Addenda, and/or any other pertinent documents form a part of the Invitation to Bid, and by reference are made a part thereof.

1. **PURPOSE:** It is the purpose and intent of this invitation to secure bids for item(s) and/or services as listed herein for The School Board of Palm Beach County, Florida (hereinafter referred to as the "Board"), the corporate body politic that governs, operates, controls, and supervises the School District of Palm Beach County, Florida (hereinafter referred to as "District").
2. **ANTI-COLLUSION:** By electronically submitting a bid, the bidder certifies that it has not divulged, discussed or compared its bid with other bidders and has not colluded with any other bidder or parties to a bid whatsoever. No premiums, rebates or gratuities are permitted either with, prior to, or after any delivery of materials. Any such violation will result in the cancellation and/or return of materials (as applicable) and the removal of the bidder from all bid lists for the School Board of Palm Beach County, Florida.
3. **ANTI-DISCRIMINATION:**
  - a. The bidder certifies that they are in compliance with the non-discrimination clause contained in Section 202, Executive Order 11246, as amended by Executive Order 11375 relative to equal employment opportunity for all persons without regard to race, color, religion, sex or national origin. The provisions of the ADA Act of 1990 pertaining to employment shall also be applicable.
  - b. The bidder shall not discriminate on the basis of race, gender, gender identity or expression, religion, national origin, ethnicity, sexual orientation, age or disability in the solicitation, selection, hiring, or treatment of sub-contractors, vendors, suppliers, or commercial customers. Bidder shall provide equal opportunity for sub-contractors to participate in all of its public sector and private sector sub-contracting opportunities, provided that nothing contained in this clause shall prohibit or limit otherwise lawful efforts to remedy the effects of marketplace discrimination that has occurred or is occurring in the marketplace, such as those specified in the Palm Beach County School Board Policy 6.143. Bidder understands and agrees that violation of this clause is a material breach of the contract and may result in contract determination, debarment, or other sanctions.
4. **BIDS:** Bids will be received electronically through a secure mailbox at Demandstar.com until the date and time as indicated in this bid document. Bids will be opened publicly at the School District of Palm Beach County, Purchasing Department, 3300 Forest Hill Boulevard, Suite A-323, West Palm Beach, FL 33406-5813, and all bidders and general public are invited to attend. It is the sole responsibility of the bidder to ensure its bid reaches Demandstar on or before the closing date and hour as indicated in this bid document.
5. **CONTRACT:** The submission of your bid constitutes a firm offer by the bidder. Upon acceptance by the Board, the Purchasing Department will issue a notice of award and purchase order(s) for any supplies, equipment and/or services as a result of this bid. The Invitation to Bid and the corresponding purchase order(s) will constitute the complete agreement between the successful bidder and the Board. Unless otherwise stipulated in

the bid documents or agreed to in writing by both parties, no other contract documents shall be issued or accepted.

6. **WITHDRAWAL:** When a bidder wishes to withdraw a bid, a written request shall be submitted to the Director of Purchasing and the request will be reviewed for consideration. In no case shall a bidder be granted a release from a bid more than one time in a two-year period. A bidder may not withdraw a bid after the final call for bids at a designated time of opening.
7. **DEFAULT:** In case of default by the bidder, the Board may procure the articles or services from other sources and hold the bidder responsible for any excess costs incurred thereby.
8. **FUNDING OUT/ CANCELLATION OR TERMINATION WITH OR WITHOUT CAUSE:**

A. With Cause: In the event any of the provisions of the Contract are violated by the bidder, the Superintendent or designee shall give written notice to the bidder stating the deficiencies and unless the deficiencies are corrected within ten days, recommendation will be made to the Board or its designee for immediate cancellation. Upon cancellation hereunder the Board may pursue any and all legal remedies as provided herein and by law. In the event that it is subsequently determined that a cancellation under this paragraph was incorrect, the termination shall be converted to a termination for convenience pursuant to the next paragraph.

B. Without Cause: The Board or its designee reserves the right to terminate any contract resulting from this Invitation to Bid at any time and for no reason whatsoever, upon giving 30 days prior written notice to the bidder. If the Contract should be terminated for convenience as provided herein, the Board shall be relieved of all obligations under said Contract. The Board or its designee shall only be required to pay to the successful bidder that amount of the Contract actually performed to the date of termination.

C. Funding Out: Florida School Laws prohibit the Board or its designee from creating obligations on anticipation of budgeted revenues from one fiscal year to another without year-to-year extension provisions in the contracts.

It is necessary that fiscal funding out provisions be included in all bids in which the terms are for periods of longer than one year.

Therefore, the following funding out provisions are an integral part of this Invitation to Bid and must be agreed to by all bidders:

The Board or its designee may, during the contract period, terminate or discontinue the items covered in this bid for lack of appropriated funds upon the same terms and conditions.

Such prior written notice will state:

1. That the lack of appropriated funds is the reason for termination, and
2. Board agrees not to replace the equipment or services being terminated with equipment and services with functions similar to those performed by

the equipment covered in this bid from another vendor in the succeeding funding period.

**“This written notification will thereafter release the School Board of Palm Beach County, Florida of all further obligations in any way related to such equipment covered herein”.**

9. When any of the parties desire to give notice to the other, such notice must be in writing, sent by U.S. Mail/Federal Express/United Parcel Service or other traceable method, postage prepaid, addressed to the party for whom it is intended at the place last specified. The place for giving notice shall remain such until it is changed by written notice in compliance with the provisions of this paragraph. For the present, the Parties designate the following as the respective places for giving notice:

To School Board: Director of Purchasing Department  
The School District of Palm Beach County  
3300 Forest Hill Blvd., Suite A323  
West Palm Beach, FL 33406

With a copy to: Inspector General  
The School District of Palm Beach County  
3300 Forest Hill Blvd., Suite C306  
West Palm Beach, FL 33406

To Contractor:

10. **BIDDERS RESPONSIBILITY:** Before submitting its bid, each bidder is required to carefully examine the Invitation to Bid delivery schedule, bid prices and extensions, insurance requirements, licensing requirements, bid closing date and time and to completely familiarize itself with all of the terms and conditions that are contained within the Invitation to Bid. Failure to do so on the part of the bidder will in no way relieve it of any of the obligations and responsibilities which are a part of the Invitation to Bid.

Bidder warrants by virtue of bidding that prices shall remain firm for a period of ninety (90) days from the date of award by the Board or time stated in special conditions.

11. **AWARDS:** In the best interest of the District, the Purchasing Department reserves the right to reject any and all bids and to waive any minor irregularity in bids received; to accept any item or group of items unless qualified by bidder; to acquire additional quantities at prices quoted on the Invitation to Bid unless additional quantities are not acceptable, in which case the bid sheets must be noted "BID IS FOR SPECIFIED QUANTITY ONLY". All awards made as a result of this bid shall conform to applicable Florida Statutes.

12. **THE JESSICA LUNSFORD ACT:** All awarded bidders who are permitted access on school grounds when students are present, who may have direct contact with any student of the District, or who may have access to or control of school funds must be fingerprinted and background checked. Awarded bidder agrees to undergo a background check and fingerprinting if he/she is an individual who meets any of the above conditions and to require that all individuals in the organization who meet any of the conditions to submit to a

Level 2 FDLE background check and FBI screening, including fingerprinting by the School District's Police Department, at the sole cost of Awarded bidder. The report of the results will be immediately transmitted to the School District's Police Department, which shall be the sole determiner of clearance. Awarded bidder shall not begin providing services contemplated by the Invitation to Bid until Awarded bidder receives notice of clearance by the School District and is issued School District badges. Compliance requiring all awarded bidders to register as a visitor before entering school property and proper display of School District badges will be strictly enforced. Neither the Board, nor its members, officers, employees, or agents, shall be liable under any legal theory for any kind of claim whatsoever for the rejection of Awarded bidder (or discontinuation of Awarded bidder's services) on the basis of these compliance obligations. Awarded bidder agrees that neither the Awarded bidder, nor any employee, agent or representative of the Awarded bidder who has been convicted or who is currently under investigation for a crime delineated in section 435.04, Florida Statutes, will be employed in the performance of the contract.

13. **DISQUALIFYING CRIMES:** The bidder certifies by submission of this bid, that neither it nor its principals is presently debarred, suspended, proposed for debarment, declared ineligible or voluntarily excluded from participation in this transaction by the State of Florida or Federal Government. Further, bidder certifies that it has divulged, in its bid response, information regarding any of these actions or proposed actions with other governmental agencies.

A person or affiliate who has been placed on the convicted vendor list following a conviction for a public entity crime may not submit a bid to provide any goods or services to a public entity, may not submit a bid to contract with a public entity for the construction or repair of a public building or public work, may not submit bids on leases of real property to a public entity, may not be awarded or perform work as a contractor, supplier, subcontractor, or consultant under a contract with any public entity, and may not transact business with any public entity in excess of the threshold amount provided in Section 287.017, Florida Statutes, for CATEGORY TWO for a period of 36 months from the date of being placed on the convicted vendor list.

The bidder(s) certifies by submission of this bid, that neither it nor its principals are presently debarred, suspended, proposed for debarment, declared ineligible, or voluntarily excluded from participation in this transaction by any State or Federal department/agency.

The awarded bidder or any subcontractor shall not employ any persons with multiple felonies and / or crimes against children. The awarded bidder must provide documented proof of efforts to comply with this requirement. The Owner may declare any non-compliance or lack of diligent effort by the awarded bidder to comply as a breach of contract and immediately terminate the services of the awarded bidder.

14. **ADVERTISING:** In submitting a bid, bidder agrees not to use the results therefrom as a part of any commercial advertising without prior approval of the District.
15. **LOBBYING:** Bidders are hereby advised that they are not to lobby with any district personnel or board members related to or involved with this bid until the administration's recommendation for award has been posted at Demandstar.com, and at the Fulton Holland Educational Services Center, Purchasing Department area. All oral or written inquiries must be directed through the Purchasing Department.

Lobbying is defined as any action taken by an individual, firm, association, joint venture, partnership, syndicate, corporation, and all other groups who seek to influence the governmental decision of a board member or district personnel after advertisement and prior to the posted recommendation on the award of the Contract.

Any bidder or any individuals that lobby on behalf of bidder during the time specified will result in rejection / disqualification of said bid.

16. **DISPUTES:** In case of any doubt or difference of opinion as to the items to be furnished hereunder, the decision of the Board shall be final and binding on both parties.
17. **LEGAL REQUIREMENTS:** Federal, state, county, and local laws, ordinances, rules, and regulations that in any manner affect the items covered herein apply. Specifically, bidder(s) is to adhere to School Board Policies 3.12 and 3.13, pursuant to the following, with respect to any criminal arrests and convictions, and is on notice thereto that any employees involved in any Chapter [435](#), Florida Statutes offenses are precluded from continuing to work on the project and must be replaced. Failure to comply may result in the immediate termination of the awarded bidder's contract at the sole discretion of the District. Lack of knowledge by the bidder will in no way be a cause for relief from responsibility.
18. **TAXES:** The School District of Palm Beach County, is exempt from any taxes imposed by the State and/or Federal Government. State Sales Tax Exemption Certificate No. 85-8013897253C-1 and Federal Excise Tax No. 59-600783 appears on each purchase order. This exemption does not apply to purchase of tangible personal property made by contractors who use the tangible personal property in the performance of contracts for the improvements of School District-owned real property as defined in Chapter 192, Florida Statutes.
19. **ASSIGNMENT:** The successful bidder shall not sub-contract, assign, transfer, convey, sublet, or otherwise dispose of the contract, or of any or all of its rights, title, or interest therein, or its power to execute such contract to any person, firm, or corporation without prior written consent of the Board.
20. **SUBCONTRACTING:** If an awarded bidder intends to subcontract any portion of the Contract for any reason, the name and address of the subcontracting firm must be submitted along with the bidder's bid or prior to use for approval. No subcontracting will take place prior to bid-awarded bidder furnishing this information and receiving written approval from the District.

The Purchasing Department reserves the right to reject a subcontractor who previously failed in the proper performance of a contract or failed to deliver on-time contracts of a similar nature, or who, the District has determined in its sole discretion, is not in the position to perform the contract due to the subcontractor's size, experience, or resources. The District reserves the right to inspect all facilities of any subcontractor in order to make determination as to the foregoing. The subcontractor will be equally responsible for meeting all requirements specified in the Invitation to Bid.

21. **DEBARMENT:** The Board shall have the authority to debar a person / corporation for cause for consideration or award of future contracts. The debarment shall be for a period commensurate with the seriousness of the causes, generally not to exceed three (3) years. When the offense is willful or blatant, a longer term of debarment may be imposed, up to an indefinite period.
22. **REQUIREMENTS FOR PERSONNEL ENTERING DISTRICT PROPERTY:** Possession of firearms will not be tolerated in or near school buildings; nor will violations of Federal and State laws and any applicable Board policy regarding Drug Free Workplace be tolerated. Violations will be subject to the immediate termination provision heretofore stated in Paragraph 16, Legal Requirements.

"Firearm" means any weapon (including a starter gun or antique firearm) which will, is designed to, or may readily be converted to expel a projectile by the action of an explosive; the frame or receiver of any such weapon; any destructive device; or any machine gun.

No person who has a firearm in their vehicle may park their vehicle on District property. Furthermore, no person may possess or bring a firearm on District property.

If any employee of an independent contractor or sub-contractor is found to have brought a firearm on District property, said employee must be terminated from the Board project by the independent contractor or sub-contractor. If the sub-contractor fails to terminate said employee, the sub-contractor's agreement with the independent contractor for the Board project shall be terminated. If the independent contractor fails to terminate said employee or fails to terminate the agreement with the sub-contractor who fails to terminate said employee, the independent contractor's agreement with the Board shall be terminated.

Bidders are advised that they are responsible to ensure that no employee, agent or representative of their company who has been convicted or who is currently under investigation for a crime against children in accordance with section 435.04, Florida Statutes, will enter onto any school site.

23. **PRODUCT RECALL:** In the event the awarded awarded bidder receives notice that a product delivered by the awarded bidder to the District has been recalled, seized or embargoed, and/or has been determined to be misbranded, adulterated, or found to be unfit for human consumption by a packer, processor, subcontractor, retailer, manufacturer, or by any State or Federal regulatory agency, the awarded bidder shall notify the District's Bid Purchasing Agent within two business days of receiving such notice. The District's acceptance or failure to reject the affected product as non-conforming shall not in any way impact, negate, or diminish the awarded bidder's duty to notify the District's Purchasing Agent that the affected product has been recalled, seized or embargoed, and/or has been determined to be misbranded, adulterated, or found to be unfit for human consumption. The form and content of such notice to the District shall include the name and description of the affected product; the approximate date the affected product was delivered to the District; the bid number; and relevant information relating to the proper handling of the affected product and/or proper disposition of the affected product by the District, if necessary to protect the health, welfare, and safety of District students or employees; and any health hazards known to the awarded bidder which may be caused or created by the affected product. The awarded bidder shall, at the option of the Purchasing Department and/or Purchasing Agent, either reimburse the purchase price or provide an equivalent replacement product at no additional cost to the District. Unless it was absolutely necessary for the District to dispose of the affected product, the awarded bidder shall be responsible for removal and/or replacement of the affected product within a reasonable time, as determined by the District, without causing significant inconvenience to the District.

At the option of the District, the awarded vendor may be required to reimburse storage and/or handling fees to be calculated from time of delivery and acceptance to actual removal or disposal. The awarded vendor will bear all costs associated with the removal and proper disposal of the affected product. The failure to reimburse the purchase price and storage and/or handling fees or to remove and/or replace the affected product with an equivalent replacement within a reasonable time without significant inconvenience to the District will be considered a default.

**GENERAL CONDITIONS FOR BIDS**

1. **USE OF OTHER CONTRACTS:** The District reserves the right to utilize any other District contract, any State of Florida Contract, any contract awarded by any other city or county governmental agencies, any other school board, any other community college/state university system cooperative bid agreement, or to directly negotiate/purchase per School Board policy and/or State Board Rule 6A-1.012(6) in lieu of any offer received or award made as a result of this bid, if it is in the best interest to do so. The District also reserves the right to separately bid any single order or to purchase any item on this bid if it is in its best interest to do so.
2. **JOINT-BIDDING, COOPERATIVE PURCHASING AGREEMENT:** All bidders submitting a response to this Invitation to Bid agree that such response also constitutes a bid to all State Agencies and Political Subdivisions of the State of Florida under the same conditions, for the same prices and for the same effective period as this bid, should the bidder(s) deem it in the best interest of their business to do so.

This agreement in no way restricts or interferes with any state agency or political subdivision of the State of Florida to rebid any or all items.

3. **FAILURE TO DELIVER:** Failure to deliver as specified and at bid price will authorize the Board to purchase these items or services from other sources and hold the bidder responsible for any excess costs incurred thereby. Further, the Purchasing Department may recommend to the School Board that the vendor failing to deliver as specified be removed as a future bidder on all bids for a period of up to three years.
4. **MANDATORY NONDISCRIMINATION CLAUSE:** The Bidder shall not discriminate on the basis of race, gender, gender identity or expression, religion, national origin, ethnicity, sexual orientation, age or disability in the solicitation, selection, hiring, or treatment of sub-contractors, vendors, suppliers, or commercial customers. The Bidder shall provide equal opportunity for sub-contractors to participate in all of its public sector and private sector sub-contracting opportunities, provided that nothing contained in this clause shall prohibit or limit otherwise lawful efforts to remedy the effects of marketplace discrimination that has occurred or is occurring in the marketplace, such as those specified in the Palm Beach County School Board Policy 6.143. The Bidder understands and agrees that violation of this clause is a material breach of the contract and may result in contract determination, debarment, or other sanctions.
5. **CONTRACTOR BID REQUIREMENTS:** As part of its bid, bidder shall provide to the District a list of all instances within the past ten years where a complaint was filed or pending against bidder in a legal or administrative proceeding alleging that bidder discriminated on the basis of race, gender, gender identity or expression, religion, national origin, ethnicity, sexual orientation, age, or disability against its subcontractors, vendors, suppliers, or commercial customers, and a description of the status or resolution of each such complaint, including any remedial action taken.
6. **CONTRACT DISCLOSURE:** Upon the District's request, and upon the filing of a complaint against awarded bidder pursuant to Palm Beach County School Board Policy 6.144, awarded bidder agrees to provide the District, within sixty calendar days, a truthful and complete list of the names of all subcontractors, vendors, and suppliers that bidder has used in the past five years on any of its contracts that were undertaken within the District relevant geographic market as defined in Palm Beach County School Board Policy 6.143, including the total dollar amount paid by bidder for each subcontract or supply contract. Awarded bidder agrees to fully cooperate in any investigation conducted by the District pursuant to this Policy. Bidder understands and agrees that violation of this clause is a material breach of the Contract and may result in contract termination, debarment, and other sanctions.
7. **INDEMNIFICATION AND HOLD HARMLESS:** Contractor shall, in addition to any other obligation to indemnify the School Board and to the fullest extent permitted by law, protect, defend, indemnify, and hold harmless the School Board, its agents, officers, elected officials, and employees from and

against all claims, actions, liabilities, losses (including economic losses), or costs arising out of any actual:

- A. bodily injury, sickness, disease or death, or injury to or destruction of tangible property, including the loss of use resulting therefrom, or any other damage or loss arising out of, or claimed to have resulted in whole or in part from any actual act or omission of the Contractor, subcontractor, anyone directly or indirectly employed by any of them, or anyone for whose acts any of them may be liable in the performance of the work; or
- B. violation of law, statute, ordinance, governmental administration order, rule or regulation by Contractor in the performance of the work; or
- C. liens, claims or actions made by the Contractor or any subcontractor or other party performing the work; or
- D. claims by third parties (including, but not limited to, Contractor's employees or subcontractors) based upon an alleged breach by Contractor of any agreement with such third party (e.g., an employment agreement or licensing agreement), or allegation that Contractor's provision of services to the School Board pursuant to the Contract infringes upon or misappropriates a patent, copyright, trademark, trade secret, or other proprietary right of the third party.

The indemnification obligations hereunder shall not be limited to any limitation on the amount, type of damages, compensation, or benefits payable by or for the Contractor of any subcontractor under workers' compensation acts, disability benefit acts, other employee benefit acts, or any statutory bar. Such indemnification shall cease at such time the contract would not be renewed.

School Board acknowledges the waiver of sovereign immunity for liability in tort contained in Section 768.28, Florida Statutes, and acknowledges that such statute permits actions at law to recover damages in tort for monetary damages up to the limits set forth in such statute for death, personal injury or damage caused by the negligent or wrongful acts or omissions of a School Board employee acting within the scope of the employee's office or employment. The School Board agrees to be responsible for all such claims and damages, to the extent and limits provided in Section 768.28, Florida Statutes, arising from the actions of their respective employees. Each party acknowledges and it is expressly understood that the foregoing shall not constitute: (i) an agreement by the School Board to indemnify the School; (ii) a waiver of sovereign immunity by the School Board; (iii) a waiver of any right or defense that the School Board has under Section 768.28, Florida Statute, or any other statute; nor (iv) as consent to be sued by third parties.

Awarded bidder recognizes the broad nature of this indemnification and hold harmless article, and voluntarily makes this covenant for good and valuable consideration provided by the School Board in support of this indemnification in accordance with the laws of the State of Florida. This article will survive the termination of this Contract.

8. **BRAND NAMES:** Use of a brand name, trade name, make, model, manufacturer, or vendor catalog number in specifications is for the purpose of establishing a grade or quality of material only. It is not the District's intent to rule out other competition, therefore, the phrase OR ACCEPTABLE EQUAL is added. However, if a product other than that specified is bid, it is the vendor's responsibility to submit with the bid brochures, samples and/or detailed specifications on items bid. The District shall be the sole judge concerning the merits of bid submitted.

Bidder shall indicate on the bid form the manufacturer's name and number if bidding other than the specified brands, and shall indicate ANY deviation from the specifications as listed. Other than specified items offered requires complete descriptive technical literature marked to indicate detail(s) conformance with specific COPYRIGHTS OR PATENT RIGHTS: Bidder warrants that there has been no violation of copyrights or patent rights in manufacturing, producing or selling the goods shipped or ordered as a result of this bid. Seller agrees to hold the purchaser harmless from any and all liability, loss or expense occasioned by any such violation.

9. **MANUFACTURER'S CERTIFICATION:** The District reserves the right to request from bidders separate manufacturer certification of all statements made in the response to Invitation to Bid.

10. **OCCUPATIONAL HEALTH AND SAFETY:** Bidder, as a result of award of the bid, delivering any toxic substances item as defined in Code of Federal Regulation Chapter 29, shall furnish to the Purchasing Department, a Material Safety Data Sheet (MSDS). The material safety data sheet shall be provided with initial shipment and shall be revised on a timely basis as appropriate.

The MSDS must include the following information:

- A. The chemical name and the common name of the toxic substance.
- B. The hazards or other risks in the use of the toxic substance, including:
  - (1) The potential for fire, explosion, corrosively and reactivity;
  - (2) The known acute and chronic health effects of risks from exposure, including the medical conditions which are generally recognized as being aggravated by exposure to the toxic substance; and
  - (3) The primary routes of entry and symptoms of overexposure.
- C. The proper precautions, handling practices, necessary personal protective equipment, and other safety precautions in the use of or exposure to the toxic substances including appropriate emergency treatment in case of overexposure.
- D. The emergency procedure for spills, fire, disposal and first aid.
- E. A description in lay terms of the known specific potential health risks posed by the toxic substance intended to alert any person reading this information.
- F. The year and month, if available, that the information was compiled and the name, address and emergency telephone number of the manufacturer responsible for preparing the information.

Any questions regarding this requirement should be directed to: Department of Labor and Employment Security, Bureau of Industrial Safety and Health, Toxic Waste Information Center, 2551 Executive Center Circle West, Tallahassee, FL 32301-5014, Telephone 1-800-367-4378.

11. **OSHA:** The bidder warrants that the product/services supplied to the School District of Palm Beach County shall conform in all respects to the standards set forth in the Occupational Safety and Health Act 1970, as amended, and the failure to comply with this condition will be considered as a breach of contract.
12. **PRICES QUOTED:** Deduct trade discounts and quote firm net prices. Give both unit price and extend total. Prices must be stated in units of quantity specified in bid specifications. In case of discrepancy in computing the amount of the bid, the UNIT PRICE quoted will govern. All prices FOB destination, freight prepaid (unless otherwise stated in special conditions). Discounts for prompt payment: Award, if made, will be in accordance with terms and conditions stated herein. Each item must be bid separately and no attempt is to be made to tie any item or items in with any other item or items. Cash or quantity discounts offered will not be a consideration in determination of award of bid(s). If a bidder offers a discount, it is understood that a minimum of 30 days will be required for payment, and the discount time will be computed from the date of satisfactory delivery at place of acceptance and receipt of correct invoice at the office specified.
13. **CONDITIONS AND PACKAGING:** It is understood and agreed that any item offered or shipped as a result of this bid shall be new (current production model at the time of the bid). All containers shall be suitable for storage or shipment, and all prices shall include standard commercial packaging.
14. **UNDERWRITERS' LABORATORIES:** Unless otherwise stipulated in the bid, all manufactured items and fabricated assemblies shall be UL listed or re-examination testing where such has been established by UL for the items offered and furnished.
15. **DELIVERY:** Unless actual date of delivery is specified, show number of days required to make delivery after receipt of purchase order in space provided. Delivery time may become a basis for making an award (See Special Conditions). Delivery shall be within the normal working hours of the user, Monday through Friday, excluding holidays unless otherwise specified on the purchase order.
16. **QUALITY:** The items bid must be new and equal to or exceed specifications. The manufacturer's standard guarantee shall apply. During the guarantee period the successful bidder must repair and/or replace the unit without cost to the District with the understanding that all replacements shall

carry the same guarantee as the original equipment. The successful bidder shall make any such repairs and/or replacements immediately upon receiving notice from the District.

17. **SAMPLES, DEMONSTRATIONS AND TESTING:**

- A. Samples of items, when required, must be furnished free of expense and if not destroyed, will upon request, be returned at the bidder's expense. Request for the return of the samples must be indicated on his or her bid. Each individual sample must be labeled with bidder's name, bid number and item number. Failure of bidder to either deliver required samples or to clearly identify samples as indicated may be reason for rejection of the bid. Unless otherwise indicated, samples should be delivered to the Purchasing Department, School District of Palm Beach County.
- B. When required, the District may request full demonstrations of any units bid prior to the award of any contract.
- C. Items may be tested for compliance with specifications under the direction of the Florida Department of Agriculture and Consumer Services, or an independent testing laboratory. Bidders shall assume full responsibility for payment for any and all charges for testing and analysis of any materials offered or delivered that do not conform to the minimum required specifications. Bidder's disposition of all items delivered in this category must be at no expense to the District.

18. **INSPECTION AND ACCEPTANCE OF GOODS:** The awarded bidder shall be responsible for delivery of items in good condition at point destination. Bidder shall file with the carrier all claims for breakage, imperfections, and other losses, which will be deducted from invoices. The District will note, for the benefit of successful bidder, when packages are not received in good condition. In the event the material and/or services supplied to the District is found to be defective or does not conform to specifications, the District reserves the right to cancel the order upon written notice to the seller and return the product **to seller at the seller's expense.**

19. **LIABILITY, INSURANCE, LICENSES, AND PERMITS:** Where bidders are required to enter or go onto District property to deliver materials or perform work or services as a result of bid award, the bidder will assume the full duty obligation and expense of obtaining all necessary licenses, permits and insurance. Bidder shall be liable for any damage or loss to the District incurred by bidder, bidder's employees, licensees of the bidder or agent or any person the bidder has designated in completion of his or her contract as a result of the bid; further bidder shall be liable for all activities of bidder occasioned by performance of the Contract. Notwithstanding the foregoing, the liability herein shall be limited to ten million dollars (\$10,000,000) and the bidder recognizes that and covenants that it has received consideration for indemnification provided herein.

20. **SPECIFICATIONS:** Any omissions of detail specifications stated herein that would render the materials/service from use as specified will not relieve the bidder from responsibility.

21. **BID BONDS AND PERFORMANCE BONDS:** Bid bonds, when required, shall be submitted with the bid in the amount specified in Special Conditions. Bid bonds will be returned to unsuccessful bidders. After award of contract, the District will notify the successful bidder to submit a performance bond in the amount specified in Special Conditions. Upon receipt of the performance bond, the bid bond will be returned to the successful bidder.

22. **QUANTITIES:** The quantities shown are estimates of the quantity of items expected to be purchased during the term of award. Actual quantities purchased may often exceed or be less than quantities shown. Orders will be placed as needed by individual locations during the contract period. The bidder agrees that the price(s) offered shall be maintained irrespective of the quantity actually purchased.

23. **ORDERING PROCEDURE:**

Specific Items: After approval of Contract award by the Board, a letter of contract acceptance will be issued to each successful bidder acknowledging which goods or services have been awarded. Separate purchase orders will be issued based on specific items at firm, fixed prices listed in the bid.

Percent Discount Catalog Bids: Separate purchase orders will be issued with pricing based on catalog and/or price lists.

**No item may be shipped or service performed that is not listed on the purchase order.**

24. **POSTING OF BID AND SPECIFICATIONS:** Invitation to Bid with specifications will be posted for review by interested parties at Demandstar.com and at the Fulton Holland Educational Services Center, Purchasing Department, 3300 Forest Hill Boulevard, Third Floor, A-Wing Suite A-323, West Palm Beach, FL 33406, on the date of bid electronic mailing and will remain posted for a period of 72 hours. Failure to file a specification protest within the time prescribed in section 120.57(3), Florida Statutes, will constitute a waiver of proceedings under Chapter 120, Florida Statutes, and applicable Board rules, regulations and policies.
25. **BID PROTEST:** If a bidder wishes to protest a bid, they must do so in strict accordance with the procedures outlined in section 120.57(3), Florida Statutes, the Invitation to Bid, and School Board Policy 6.14.

Any person who files an action protesting bid specifications, a decision or intended decision pertaining to this bid pursuant to section 120.57(3)(b), Florida Statutes shall post with the Purchasing Department, at the time of filing the formal written protest, a bond secured by an acceptable surety company in Florida payable to The School Board of Palm Beach County, Florida in an amount equal to one percent (1%) of the total estimated contract value, but not less than \$500.00 nor more than \$5,000.00. Bond shall be conditioned upon the payment of all costs that may be adjudged against the protester in the administrative hearing in which the action is brought and in any subsequent appellate court proceeding. In lieu of a bond, a cashier's check, certified bank check, bank certified company check or money order will be acceptable form of security. If, after completion of the administrative hearing process and any appellate court proceedings, the District prevails, it shall recover all costs and charges included in the final order of judgment, including charges by the Division of Administrative Hearings. Upon payment of such costs and charges by the protester, the protest security shall be returned.

26. **TIE BID:** According to FS 287.087, tie bid preference shall be awarded to vendors with Drug Free Work Place programs. Whenever two or more are equal with regard to price, quality, and service, a bid received from a business that certifies that it has implemented a Drug Free Work Place program shall be given preference in the award process. In the event both vendors have a Drug Free Work Place preference shall be awarded to the vendor who is certified in the following order: as a M/WBE certified with the School District, as a SBE certified with the School District. If both vendors meet all three requirements, according to standard purchasing practice, the Director or Manager of Purchasing will flip a coin to break the tie. Vendor's company name closest to the letter "A" will always be assigned heads in the coin toss.
27. **INTERPRETATIONS:** Neither Demandstar nor any employee of the District is authorized to interpret any portion of the Invitation to Bid or give information as to the requirements of the bid in addition to that contained in the written bid document. Interpretations of the bid or additional information as to its requirements, where necessary, shall be communicated to bidders by written addendum.
28. **SPECIAL CONDITIONS:** If any conflict exists between any of the Special Conditions and/or the Specifications and either the General Conditions for Bids or the Instructions to Bidders, the Special Conditions and/or Specifications shall govern.

## 15C-32B - SPECIFICATIONS

### 1) General:

The purpose for this bid is to establish a pool of qualified vendors for the purchase and installation of playground equipment, playground surfacing, fabric shade structures, outdoor fitness equipment and fitness trails

- This bid is specifically for the purchase and installation of:
  - Playground equipment
  - Playground surfacing – including PIP and Artificial Turf
  - Outdoor fitness equipment
  - Fabric shade structures
  - Fitness trails which includes fitness stations and surfacing
- If awarded vendors sell other products, they may not be purchased referencing this bid (this includes benches, picnic tables, trash receptacles, etc.)
- Only vendors awarded under this bid will be allowed to participate in any upcoming projects for playgrounds, surfacing, repairs, fabric shade structures, outdoor fitness equipment and fitness trails
- If bidding to supply equipment, you must also either successfully bid on the installation of equipment and surfacing, site preparation and to supply ADA surfacing (meeting guidelines) **or** list your certified installer, who must submit a bid **and** be awarded a contract to supply/install all of these items
  - Bids not meeting this requirement will be rejected**
- The School District of Palm Beach County currently has 106 elementary schools, 33 middle schools & 23 high schools
  - Elementary schools have a minimum of two playgrounds, there are pre-school playgrounds at several high schools and schools with Head Start programs and several middle schools have outdoor fitness areas
- Bid awarded vendors will be given opportunities to submit proposals for all projects covered under this bid, including playgrounds for both existing school sites and new schools, as funding becomes available
- All products must be new, unused, of the latest design and technology and from the most current product lines.
- All installations shall be in compliance with District master Specifications where applicable

### 2) Warranty:

Bidders should include the following warranty compliance documents with their bid (upload and submit electronically through DemandStar) or provide to the purchasing agent within 24 hours of request:

- Applicable warranty and/or guarantees of equipment, surfacing and installations including any conditions and response time for repair and/or replacement of any components during the warranty period
- Availability of replacement parts
- Life expectancy of equipment and surfacing under normal use

At a minimum, the following warranties shall apply:

- A minimum of 5 years warranty shall be in effect for all equipment, installations, PIP surfacing, concrete curbing and sidewalks
- Artificial Turf shall have a minimum of 7 years warranty
- Recapping poured in place surfacing shall be warranted for a minimum of 3 years
- Sealer over poured in place surfacing shall be warranted for a minimum of 1 year
- Damage due to vandalism is exempt from warranty

### **3) Catalogs for Playground Equipment and Outdoor Fitness Equipment:**

Firm Percentage Discount: (see Item 1 on Bid Summary document)

- Bidder shall indicate in the space provided on the Bid Summary Document a single firm fixed percentage discount for each manufacturer's product line
- The District will accept a discount of 0%
- Bidders must bid a single fixed percentage discount, ex. 12% is acceptable, 11.075% isn't

Catalog and Price List:

- Awarded vendors for playground equipment and/or outdoor fitness equipment shall deliver their current catalog with prices or a price list if the catalog doesn't have prices to:  
School District of Palm Beach County  
Purchasing Department, Attn: Karen L. Adducci  
3300 Forest Hill Boulevard, Suite A-323  
West Palm Beach, FL 33406

Catalog Updates/Annual Replacements:

- The discounts, terms and conditions of this bid are to remain firm throughout the contract period
- During the contract period, the vendor may issue replacement catalogs
- The catalog replacements are to be delivered to the Purchasing Agent no less than 21 days prior to the effective date of same, along with a written request for acceptance and stating the effective date of such changes
- Prices may not be increased except when a new catalog with prices has been issued and accepted by the Purchasing Agent

### **4) Balance of Line:**

- The "balance of line" shall include new manufacturer's product line, new products, additional services and upgraded catalogs or products under the general category of items awarded under this bid
- Additions shall be submitted as they occur
- If awarded vendor is an authorized representative for a manufacturer and that relationship ends during the contract, written notice from the bid awarded company must be presented to the Purchasing Agent with a request for them to be allowed to provide a different manufacturer's product line for the duration of the contract
- If this occurs, it is the manufacturer's responsibility to find another bid awarded vendor to sell and install their product line for the duration of the contract and to receive approval from the Purchasing Agent

**5) Playground Equipment, Surfacing and Outdoor Fitness Equipment:**

- All equipment and surfacing provided must, at a minimum, meet the following standards: ADA (Americans with Disabilities Act) ASTM (The American Society for Testing and Materials), CPSC (Consumer Product Safety Council) and IPEMA (International Playground Equipment Manufacturers Association and all District standards
- Proposed playground packages must be approved and signed off by the District's certified playground safety inspector (CPSI) for compliance with national standards prior to a purchase order being issued.
- Regardless of how a project is funded, it must fully comply with all District standards and the current safety and ADA related requirements
- Any playground equipment or surfacing installed on Palm Beach County Schools' property not complying with safety regulations and all requirements in this bid shall be removed or replaced (at the sole discretion of the District) at no cost to the District

**5a) General Design Requirements:**

Playground and outdoor fitness equipment shall meet the following requirements:

- Equipment for Pre-K shall not exceed four feet in height
- Equipment for primary students shall not exceed six feet
- Equipment for intermediate students shall not exceed eight feet in height unless designed for uses other than climbing
- Outdoor fitness equipment shall be age appropriate
- Equipment shall be free of points, sharp edges and protrusions that may cut or puncture
- Equipment shall be free of protrusions and other elements that may snag clothing or body parts
- Equipment shall be free of angles or openings that may entrap body parts
- Equipment shall be free of pinch or crush points
- Equipment shall be free of splinters and not be subject to future splintering
- Equipment shall have slip resistant walking and climbing surfaces
- Equipment shall have components that drain freely and do not collect water
- Equipment shall have steps and handholds of proper size, spacing and incline where necessary to assist climbing
- Closed risers shall be placed at all steps
- Equipment shall have all moving parts constructed of materials that minimize the potential for impact injuries
- Equipment shall have handrails, raised edges and other barriers where necessary to minimize the potential for falls
- Equipment shall have vandal-proof connectors that cannot be loosened or unfastened without special tools
- Equipment shall permit easy access by adults for maintenance and emergencies
- Equipment shall provide more than one means of access and exit
- Equipment shall be designed to support the maximum possible load able to be imposed on the apparatus
- Equipment shall be designed to be permanently anchored in place
- Equipment shall be constructed of non-rusting and nontoxic materials and paints
- Equipment shall be constructed of materials that will remain durable in an outdoor environment
- All main (in-ground) support posts shall be powder coated aluminum

- Equipment shall not be constructed of wood or contain wooden components
- There shall be no tether balls or benches (or other seating) placed inside either the playground area or outdoor fitness equipment area
- If in the professional judgment of the District's Risk Management staff, a risk issue is raised regarding any equipment or surfacing, the final decision will be made by the District's Risk Management Certified Playground Safety Inspector (CPSI)
- A "Certificate of Completion" from the Building Department for permitted work is required
- No new playground package will be issued a final approval letter until the "Certificate of Completion" is received by Risk Management
- There shall be no walls, grates, drains, valves, or any other possible obstructions within a 6' perimeter of any playground unless protected by a 6' high (black vinyl) 9 Ga. fence, or one that matches existing chain link 6' high fences
- Access - All playgrounds shall be ADA compliant including having code compliant sidewalks to the ADA surfacing
- Equipment repairs, revisions or replacements by the vendor shall require prior approval from Risk Management

#### **5b) Curbs for Playgrounds:**

- **PIP surfacing:** Installer shall provide and install 4 inch wide x 12 inch deep new concrete curb at playground perimeter, with cut-outs for drainage. Installer shall submit a proposed curb detail for approval for monolithic slab installation
- **Artificial turf** - Installer shall provide and install 6 inch wide x 12 inch deep new concrete curb at playground perimeter, saw cut every 10 feet. Installer shall submit a proposed curb detail for approval for monolithic slab installation

**5c) Fencing:** (Fencing will **not** be purchased as part of this bid. It will be provided by the District's contracted vendor for fencing. This information is included because it is part of the playground requirements)

- All Pre-K, kindergarten and ESE (ADA) playgrounds will be surrounded with a 6' high, 9 gauge black vinyl double knuckle chain link fence, or one that matches existing chain link 6' high fences
- When the playground is located inside a school's existing 6' high perimeter fence, a 4' high fence may be allowed, at the District's discretion
- Fences surrounding K-2 playgrounds are required to have one gate equipped with panic hardware if under 2500 square feet and if over 2500 square feet two gates equipped with panic hardware are required
- Fencing shall comply with ASTM standard F2049-11

**5d) Standards:** Equipment manufacturers, vendors and installers shall adhere to the following safety standards:

American Society of Testing and Materials (ASTM)  
 ADA/ABA Accessibility Guidelines  
 Consumer Product Safety Commission (CPSC)  
 International Playground Equipment Manufacturers Association (IPEMA)  
 District standards where they exceed those guidelines  
 District Master Specifications - use this link  
<http://www.palmbeachschools.org/buildingdepartment/DMS2013pdf.asp> )  
 All state, federal and local safety rules and regulations

**5e) Signs:**

- Signage for all playgrounds shall be provided and installed in compliance with ASTM standards
- Signs may also be purchased for existing playgrounds

**5f) Replacement Parts:**

- Replacement parts, whether under warranty or not, must be available in the United States or the vendor must give the District an option of delivery by Priority shipping or overnight delivery, payable by the District
- Bidder shall indicate in space provided on the Bid Summary document all manufacturers' lines they are authorized to sell parts for and the firm percentage discount of list price
- Replacement parts shall be new
- Failure to deliver parts in a timely manner may result in bidder being considered non-compliant and removed from the list of bid awarded vendors eligible to do any business under this bid

**6) Installation of Surfacing and Equipment:**

If bidding equipment only and listing multiple installers (who are also awarded contracts), it will be the responsibility of the vendor providing the equipment to determine which certified installer will do each job; however, if the installers have bid different rates, the District will only be billed the lowest rate for the installation.

**6a) The installer shall comply with the following:**

- Each day an employee of the installer shall report to the school's main office, register in the appropriate sign-in book, list the number of employees on the school site and sign out at the end of the day
- Furnish, at own expense, all supervision, equipment, machines, tools, materials, labor, transportation, and anything necessary to perform site preparation, installation of equipment and surfacing
- The School District will provide water and electricity from the point of closest hook-up only (no hoses or electrical cables will be provided)
- The School District will be responsible for sprinkler relocation when necessary
- Contractors will consider the means of egress from any playground structure and be certain that no component presents an obstruction
- Private locates shall be the responsibility of the installing contractor in order to verify all interfering private or public owned utility locates (the cost shall be billed to the District)
- Ultimately, the Installer shall be held responsible for utility repairs required as a result of construction damages
- Erect and maintain a barrier around the entire playground until it has passed inspection by the District's CPSI and been released for use
- Protect all school buildings, structures, and utilities that are underground, above ground, or on the surface from their operations which may be hazardous and/or damaging to school facilities
- Protect all personnel (school staff and installer's employees), and students or others on school campuses against hazards and/or injuries that might result from installer's work
- This shall include, but not be limited to, the erection of barricades and signs to isolate the work site and minimize the risk of injury to anyone on the school campus

- Safeguard all tools, materials, and equipment at all times, including after work hours
- Provide security for the site while surfacing is curing, drying, etc. (there shall be no cost to the District for this security)
- Not prohibit entrance or exiting from school fire lanes, doorways, gates, etc.
- Verify and be responsible for the accuracy of all field measurements
- Ensure that all work is installed straight, level, plumb and in a professional manner
- Have frequent pick-up of all rubbish, refuse, scrap materials, and debris
- Remove all rubbish, scrap, etc., from the school site
- No rubbish shall be used as fill on the school site and installer may not use the school's dumpster
- Leave the work site in a neat and orderly manner at the end of each work day
- At completion of the installation, the site shall be in a ready to use condition, free of any debris
- Repair or replace, according to local codes and School District's satisfaction, all water lines, sanitary lines, electrical lines, curbs, sidewalks, streets, parking lots, fences, grassed areas, etc., broken or damaged as a result of the installer's operations
- Restore the site to its original condition, which may include re-sodding the area affected by their work with sod of the same variety and quality as the surrounding sod
- Where no sod exists prior to installation, the installer shall restore grade to a level consistent with the surrounding grade, and provide and install sod, if requested by the District (this sod is billable)
- All finish grading and final cleanup shall be the responsibility of the vendor
- Provide a maintenance manual and repair kit for all installed playground structures/equipment, delivered to the District Maintenance Plant & Operations (MP&O), 3300 Summit Blvd, West Palm Beach, FL., clearly labeled as to the school site it is for (there shall be no cost to the District)

**6b) Installation crew:**

- Supervisor shall be CPSI certified, be on site at all times, be fluent in English, be thoroughly knowledgeable of all plans, specifications and other contract documents and have the authority to act on the installer's behalf
- For each awarded project, vendor will provide:
  - Supervisor's name and certification
  - A list of the crew
  - Confirmation that all crew has completed the District background check and has a District issued badge in compliance with the Jessica Lunsford Act
- Installation crew must be factory certified to install equipment and surfacing
- All of the installer's employees and subcontractors shall wear School District badges and fully comply with the Jessica Lunsford Act
- Comply with School Board Policies and Rules prohibiting smoking and consumption of alcohol and illegal drugs while anywhere on District property.
- All of the installer's employees shall be clean and appropriately dressed at all times, whether school is in session or not. Shirts shall be worn at all times.
- Installation crew shall only use restroom facilities as determined at the pre-construction meeting
- At no time shall anyone use student restroom facilities, including when school is not in session.

**6c) Sanitary Facilities**

- The Contractor shall provide sanitary temporary toilet buildings for the use of all workers
- All toilets shall comply with local codes and ordinances
- Toilets shall be kept supplied with toilet paper and shall have workable door fasteners
- Toilets shall be serviced no less than once weekly and shall be present in a quantity of not less than 1 per 20 workers or as otherwise required by OSHA regulation
- The toilets shall be maintained in a sanitary condition at all times

**6d) The Jessica Lunsford Act:**

- All awarded bidders who are permitted access on school grounds when students are present, who may have direct contact with any student of the District, or who may have access to or control of school funds must be fingerprinted and background checked
- Awarded bidder agrees to undergo a background check and fingerprinting if he/she is an individual who meets any of the above conditions and to require that all individuals in the organization who meet any of the conditions to submit to a Level 2 FDLE background check and FBI screening, including fingerprinting by the School District's Police Department, at the sole cost of Awarded bidder
- The report of the results will be immediately transmitted to the School District's Police Department, which shall be the sole determiner of clearance
- Awarded bidder shall not begin providing services contemplated by the Invitation to Bid until Awarded bidder receives notice of clearance by the School District and is issued School District badges
- Compliance requiring all awarded bidders to register as a visitor before entering school property and proper display of School District badges will be strictly enforced
- Neither the Board, nor its members, officers, employees, or agents, shall be liable under any legal theory for any kind of claim whatsoever for the rejection of awarded bidder (or discontinuation of awarded bidder's services) on the basis of these compliance obligations
- Awarded bidder agrees that neither the awarded bidder, nor any employee, agent or representative of the awarded bidder who has been convicted or who is currently under investigation for a crime delineated in section 435.04, Florida Statutes, will be employed in the performance of the contract
- In addition, all awarded vendor's representative who attend mandatory site visits in order to bid on a project are required to have complied with the Jessica Lunsford Act and wear their District issued badges at all meetings

**6e) Dumpsters:**

- Dumpsters and all job site trash are the responsibility of the installer
- The District representative will provide a list of recommended dumpster companies by area
- Dumpsters must be located so as not to interfere with traffic at the school site and shall be promptly removed upon completion of job
- The installer shall clean or make any necessary corrections to any area damaged by a dumpster

**7) Surfacing:** (See Items 3 & 4 on Bid Summary Document)

- Surfacing for all playgrounds shall be poured in place with the exception of some Pre-K playgrounds where the District may approve artificial turf
- Surfacing must be IPEMA certified and a copy of the certification shall be provided with each awarded proposal package
- There will be no loose fill type surfacing and no tiles
- Provide & install clean fill as needed, compacted to 2,500 PSF (compaction test to be provided by vendor) to ensure positive drainage away from playground
- Poured In Place Surfacing shall meet current ASTM standards for impact attenuation and maneuverability
- A mandatory 4 inch wide x 12 inch deep concrete perimeter curb is required for poured in place surfacing and a 6" wide X 12" deep concrete perimeter curb is required for all synthetic turf applications
- All playground and fitness trail surfacing material being bid must be approved by the District's Risk Management staff
- Product specifications, (M)SDS and samples if requested, must be provided within twenty-four hours of request

**7a) Random Testing of Surfacing:**

- A sampling of the surface material that is installed may be tested to be certain its quality and consistency matches that which was ordered
- In order to verify that the proper amount of binder is being used; a random sample will be collected by District staff and tested at an independent lab
- If it fails, the vendor agrees to provide a seal coating in 2 years or increase the length of the warranty and will reimburse the District for the testing
- If a vendor's sample fails more than twice, the District may cancel the contract without penalty. This will not relieve the vendor from warranty obligations

**7b) Surfacing – Repair, Recap and/or Replace** (See Item 15 on Bid Summary)

- Projects to repair, seal, patch, recap, and or replace surfacing will be posted on DemandStar as an RFQ and a mandatory site visit will be scheduled with bid awarded vendors
- Only awarded vendors for Item 15 on the Bid Summary will be eligible to participate in these projects
- All RFQ responses must be uploaded to DemandStar by the date and time specified for each project
- The EPDM layer will be 5/8"
- Pre and Post drop test will be performed by the District's Risk Management Certified Playground Safety Inspector (CPSI) when surfacing repairs encompass the entire area to ensure it conforms to ASTM F-1292 requirements
- Complete tear-outs of surfacing will not require a pre-test
- All materials must be IPEMA certified and documentation will be required
- Materials and installations shall comply with all current applicable codes and standards
- Vendor shall ensure the entire surface is cleaned upon completion of repairs or any work
- Upon award and receipt of a purchase order, work must be scheduled and completed in a timely manner and to the satisfaction of the District
- There will be no charge for consultation or troubleshooting on any project

**7c) Artificial turf – where fall protection is Not required:** (See Item 5 on Bid Summary Document)

- Projects will be posted on DemandStar and a mandatory site visit will be scheduled with bid awarded vendors
- Artificial turf shall comply with the current and any updated District Master Specifications
- All turf seams will be secured with Velcro **and** adhesive and the turf will be secured firmly so that it cannot be lifted in any manner
- Install per manufacturer's specifications and ensure proper drainage
- A mandatory 6" wide X 12" deep concrete perimeter curb will be used for all synthetic turf applications

**8) Fabric Shade Structures** (See Item 16 & 17 on Bid Summary)

- When funding is available during the term of this contract, projects for Fabric Shade Structures will be posted on DemandStar as an RFQ and a mandatory site visit will be scheduled with bid awarded vendors
- Only awarded vendors for this product (Item 16 & 17) on the Bid Summary will be eligible to participate in these projects
- All RFQ responses must be uploaded to DemandStar by the date and time specified for each project
- There will be no charge for consultation or troubleshooting on any project
- All quotes must provide cost for labor, materials and installation
- All free-standing shade structures must be approved by the District Building Department
- Permits and inspection are required
- Signed/sealed engineered drawings showing the structural supports/foundations meet 150 mph wind loads are required
- Engineered drawings must be prepared by a State of Florida Registered engineer
- The fee for providing engineered drawings, signed and sealed by a State of Florida registered engineer shall be stated on the Bid Summary document
- Shade structures shall be certified by a US Testing Laboratory, comply with Florida Building Code, meet wind load and comply with District Master Specs (a copy is included in this bid)
- Fabric cover shall meet the requirements of NFPA 701, Standard Methods of Fire Tests for Flame Resistant Textiles and Film. A certificate or label sewn into fabric showing compliance must be provided for each project
- Provide instruction on care of the fabric and any requirements for re-treating the fabric to maintain its fire retardant classification
- This bid does not include covered walkways, aluminum awnings or shade structures other than fabric

**9) Fitness Trails** (See Items 18 & 19 on Bid Summary Document)

- When funding is available during the term of this contract, projects for Fitness Trails will be posted on DemandStar as an RFQ and a mandatory site visit will be scheduled with bid awarded vendors
- Only awarded vendors for Items 18 & 19 on the Bid Summary will be eligible to participate in these projects
- All RFQ responses must be uploaded to DemandStar by the date and time specified for each project
- There will be no charge for consultation or troubleshooting on any project
- All quotes must provide cost for labor, materials and installation
- Fitness trail equipment shall be appropriate for the age level at the site or school
- Fitness trail equipment shall include introductory signs, station signs, exercise stations, heartbeat check guides and all components in compliance with ASTM, CPSC or ADA laws
- Signs shall not be made of wood or contain wood components
- The awarded vendor shall be responsible for ensuring any and all fitness trail surfacing, fall zones, fall protection, pathways and equipment for Palm Beach County Schools meet the safety requirements as stated in this bid document including any updates by the District, ASTM, CPSC or ADA laws regardless of how the project is funded
- Proposed Fitness Trail packages must be approved and signed off by the District's certified playground safety inspector (CPSI) and the District's Building Department if required, prior to an order being placed
- Fitness trail stations shall meet the same requirements as playground equipment and outdoor fitness equipment
- Fitness trails may have different types of ADA surfacing if approved by the District's certified playground safety inspector (CPSI)
- Bidders should submit surfacing spec sheets, test data, etc. with bid or within 24 hours of request by the purchasing agent, for review and approval of any surfacing bid for fitness trails
- The District reserves the right to utilize other bids for the purchase and installation of the fitness trail surfacing if it is deemed to be in the best interest of the District

**10) Proposals:**

- The District's Playground and Outdoor Fitness Equipment Proposal form will be used for all proposals to provide & install playgrounds and outdoor fitness equipment and surfacing
- All successful bidders will make copies of this form as needed at no cost to the District
- When a project has been awarded, the awarded vendor will prepare 5 sets of packages containing all of the following for review by the District's Risk Management Certified Playground Safety inspector (CPSI):
  - 1) Playground Proposal form
  - 2) A list of components and the price for each as listed in their catalog/price list
  - 3) 3-Dimensional drawing
    - With a 180 degree view showing the type and color of surfacing
    - State the grade level on the drawing, under the school's name
    - Show the fall/use zone measurements, height of equipment, and ADA access route
    - List the number and name of the playground components meeting ADA requirements for lower and upper level components
  - 4) 2-Dimensional drawing;
    - Shall be on 11" X 17" paper with NO font being less than 1/8"
    - List the number and name of the playground components meeting ADA requirements for lower and upper level components
    - Identify "North" on the drawing
    - Include a scale on the drawing
    - State the grade level on the drawing, under the school's name
    - An identifying symbol shall be added to indicate that a curb will surround the playgrounds (4" for poured in place)
  - 5) Architectural Site Plan (to be provided by the District facilitator) clearly indicating the location of the playground(s) or fitness trails, the ADA compliant access route and the geographical orientation
  - 6) (M)SDS forms and IPEMA (The International Playground Equipment Manufacturers Association) certification for the surfacing
  - 7) A letter of compliance from the manufacturer describing their compliance with 16 CFR Part 1303 and Section 3 Federal Hazardous Substances Act with regard to lead, and Section 8 of the Consumer Product Safety Act with regard to phthalates

**11) Process:**

- Project is identified, funded and a requisition is processed
- Request For Quotes (RFQ) is prepared and posted on DemandStar by the purchasing agent
- RFQ is only open to bid awarded vendors. Note: A vendor may be removed from the list of eligible vendors at the sole discretion of the District purchasing agent for a period of time which may include the remainder of the contract. This would prevent the vendor from participating in any project and their name will be removed from the list of Bid Awarded Vendors.
- Mandatory site visit scheduled - vendor representatives will view the site, take measurements and be given project specifications
- Any project specific questions will be addressed and published through DemandStar as an addendum
- If tree trimming or removal is required, vendor may be requested to provide a quote
- Vendors prepare a proposal and upload it to DemandStar by the due date and time
- Projects for shade structures and surfacing repairs or replacements will be awarded to the lowest bidder or as stated in the RFQ
- For new or replacement playgrounds
  - All qualified proposals are reviewed and short-listed to top 3 best meeting the needs of the school
  - The three selected will make oral presentations to school based staff
  - The staff will rank the proposers as first, second and third
  - Selection may be based on innovation of design, number of components/activities, aesthetic, play value of the equipment, etc.
  - Award tabulation will be posted on DemandStar
  - Awarded vendor will prepare five (5) packages and deliver them to the District's facility representative for review to ensure they are complete
  - District's Facility representative will deliver the packages to the Risk Management department for review and signed approval by a District CPSI
  - Within seven (7) days, the CPSI shall approve or request additional information or changes
  - If the equipment changes or anything requested affects the cost of the project, the vendor will submit five (5) revised Playground Proposal forms and five (5) sets of any other documents or drawings that have been revised
  - Approved and sign-off packages go to purchasing agent who issues a PO which is notice to begin project
- For all projects, District's facility representative will schedule pre-construction meeting with awarded vendor, installation supervisor and school representative
  - The meeting will address:
    - Schedule for deliveries and installation
    - Site access
    - Dumpster requirements
    - Sanitary facilities
    - Permitting if required
    - Vendor will provide supervisor and crew documentation (per requirements listed above)
    - Any other pertinent information

- District's facility representative shall periodically check installation process and verify that all workers on site are fully complying with all District policies, are badged and comply with the Jessica Lunsford Act
- District's facility representative verifies the job is complete
- Where required, a District CPSI will inspect the equipment and surfacing for safety and ADA compliance
- Any other issues such as quality will be addressed by the purchasing agent and the District's facility representative
- Payment will be made for both materials and installation only after successful inspection by the District's CPSI, completion of a Professional Performance Evaluation –PPE (Vendor evaluation) and receipt of Certificate of Completion
- No deposits or partial payments will be made
- New school construction (including replacement school construction)  
The above process will be followed except after award of the project, the installer shall coordinate all deliveries and work with the Construction Manager
- If the District makes any changes to the above procedures during the contract, all awarded vendors will be notified by the Purchasing Agent and shall fully comply with any revisions.

### **12) Post Bid Award Meeting**

- After award of this contract, all awarded vendors will attend a mandatory start-up meeting at the District (exact location, date & time to be determined)
- District staff involved in these types of projects will be available to review basic District guidelines and requirements
- All awarded vendors are required to have a representative attend in order to participate in projects available through this bid

### **13) Glossary of Terms**

ADA	Americans with Disabilities Act
ASTM	American Society for Testing Materials
CM	Construction Manager
CPSC	Consumer Product Safety Commission
CPSI	Certified Playground Safety Inspector
IPEMA	International Playground Equipment Manufacturers Association
MSDS	Material Safety Data Sheets
NPSI	National Playground Safety Inspector
PPE	Professional Performance Evaluation

The School District of Palm Beach County  
Project Name  
SDPBC Project No.

SECTION 13 31 00  
PLAYGROUND SHADE STRUCTURES

PART 1 GENERAL

1.1 RELATED DOCUMENTS

- A. Drawings and general provisions of the Contract, including General and Supplementary Conditions and Division 1 specification sections, apply to work in this section.

1.2 SUMMARY

- A. The shade structure contractor shall be responsible for design, engineering, fabrication, and supply of the work specified herein.
- B. The intent of this specification is to have only one manufacturer responsible for all the functions.

1.3 REFERENCES

- A. ASCE 7 – Minimum Design Loads for Buildings and other Structures
- B. ASTM A135/A135M – Standard Specification for Electric Resistance Welded Steel Pipe
- C. ASTM A500/A500M – Standard Specification for Cold Formed Welded and Seamless Carbon Steel Structural Tubing in Rounds and Shapes
- D. ASTM E84 – Standard Test Method for Surface Burning Characteristics of Building Materials
- E. NFPA 701- Standard Methods of Fire Tests for Flame Propagation of Textiles and Films
- F. FBC - Florida Building Code
- G. FFPC Florida Fire Prevention Code

1.4 SUBMITTALS

- A. Provide installed reference sites with structures for similar scope and installation engineered to the FBC requirements.
  - 1. Provide minimum of 5-references in Southeast Florida, preferably 5-years or more in age.
  - 2. Include in reference list of structure dimensions with install dates and project locations.
- B. Provide material samples and color available.
- C. Provide signed and sealed engineered drawings and structural calculations prepared by Florida licensed Engineer.
- D. Provide certification the fabric meet NFPA 701 requirements.

1.5 WARRANTY

- A. The successful bidder shall provide a one-year warranty on all labor and materials.
- B. Provide a supplemental non-prorated 10-year warranty from the manufacturer on fabric including stitching and 20-years on the structural integrity of the steel, from date of substantial completion.
- C. The warranty shall not deprive the Owner of other rights under the provisions of the Contract Documents, are in addition to, and run concurrent with, other warranties made by the Contractor under requirements.

PART 2 PRODUCTS

The School District of Palm Beach County

Project Name

SDPBC Project No.

## 2.1 GENERAL

- A. Design and manufacture the shade product to the most exacting specifications by skilled craftsmen, and certified by Professional Engineers for structural soundness of designs.
- B. Ship all shade products knocked-down, with complete assembly instructions, and ready for easy in-field installation
- C. Engineer the structures to meet or exceed the requirements of the FBC.
- D. Design to the following wind speeds:
  - 1. Frame only            Wind load of area installed per current wind map for Risk Category I
  - 2. Frame w/canopy    90 M.P.H.
- E. Material:
  - 1. All materials shall be structurally sound and appropriate for safe use.
  - 2. Ensure product durability by the use of corrosion-resistant metals such as stainless steel, and coatings such as zinc plating, galvanizing, and powder coating on steel parts, subject to the product-specific requirements.
  - 3. Use fabrics with UV-stabilizers and fire retardants for longevity and safety.
- F. Packaging: Wrap all metal posts, rafters, and beams to protect the powder coat finish during shipping.
- G. Weldments: Factory weld all tubing members using Certified Welders meeting American Welding Society (AWS) specifications and to the highest standards of quality workmanship.
  - 1. Finish the weldments with a zinc-rich galvanized coating.
  - 2. Minimize or omit field welding in the assembly of the shade products.
- H. Posts, Structural Frame Tubing, and Hardware:
  - 1. Use cold-formed and milled tubing meeting ASTM A135/A135M and ASTM A500/A500M requirements.
  - 2. Test material in accordance with ASTM E8.
  - 3. Minimum yield is 40,000 psi, minimum tensile strength of 45,000 psi on all posts.
  - 4. Pre-cut all tubing to appropriate lengths, and galvanize all outside surfaces with an exterior corrosion-resistant zinc-rich coating.
  - 5. Where required, schedule-40 support pipes of hot-dip galvanized or powder-coated black steel.
  - 6. All fastening hardware shall be stainless steel.
- I. Powder-coating Process:
  - 1. Completely clean and properly, pre-treat all powder-coated parts before coating.
  - 2. Apply powder coating electrostatically and oven-cured at 375 to 425 degrees Fahrenheit.
  - 3. Powders shall meet or exceed ASTM standards for Adhesion, Hardness, Impact, Flexibility, Overbake Resistance, and Salt Spray Resistance.
  - 4. Owner shall select color from manufacturer's palette.
- J. Design the footings per the FBC for the specified structure.
- K. Roofing:
  - 1. Design structural frames use with shade fabric.
  - 2. Attach the fabric to frame using a vinyl covered minimum diameter galvanized and clear vinyl coated cable.
  - 3. Provide zinc-plated copper cable fasteners for maximum corrosion resistance.

## 2.2 FASTENING SYSTEM

- A. Deliver the Shade Fabric complete with independent cables pre-inserted in fabric hems.
- B. Loop and clamp each cable at each end.

The School District of Palm Beach County

Project Name

SDPBC Project No.

- C. Provide a Fastening System with a factory-installed device at each roof rafter corner.
- D. The fastening device should feature a concealed mechanism.
- E. Attach cables to a hook welded to the moving sleeve, thereby distributing tension evenly over rafters and not directly onto the mechanism.
- F. Seal the rafters with no penetrations on the top side, thereby preventing water from entering.
- G. Provide a locking cap at the end of each rafter with a vandal-resistant bolt (special wrench provided by the manufacturer) to prevent unauthorized access to the fastening device mechanism.
- H. Provide a system to adjust the tension on the fabric, which staff controls with the proper tool supplied by the vendor.
- I. Provide instructional video DVD on handling the shade structure, exact procedure for removing, and re-attaching canopy using an actual shade structure in the field.

### 2.3 FABRIC

- A. Shade Fabric:
  - 1. Knitted of monofilament and tape construction high-density polyethylene with Ultra Violet (U.V.) stabilizers and flame retardant, UV-Block Factor varies by standard color offered from 91% to 99%.
  - 2. Normal Thickness: 0.057 inches
  - 3. Fabric Mass: Min 337 g/m<sup>2</sup>
  - 4. Light Fastness: 7-8 (Blue Wool Scale)
  - 5. Weather Fastness: 4-5 (Grey Scale Test)
  - 6. Tear Resistance: Warp 210N Weft 276N
  - 7. Breaking Force: Warp 786N Weft 1544N
  - 8. Bursting Pressure: Mean 3125kPa
  - 9. Bursting Force: Mean 1775N
  - 10. All hems and seams are double rowlock stitched using exterior grade UV-stabilized polyethylene sewing thread.
- B. Flammability:
  - 1. Treat shade fabric with fire retardants that pass the requirements established under the NFPA 701 Test Method 2 test standards for flammability, including the accelerated water leaching protocol.
  - 2. Furnish written evidence of compliance with this standard, including with accelerated water leaching protocol, with bid proposal.

## PART 3 EXECUTION

### 3.1 INSTALLATION

- A. Installations of shade structure(s) by an installer who shall comply with the manufacturer's instructions for assembly, installation, and erection, per approved drawings.
- B. The site shall be free of construction debris upon the completion of the project.

END OF SECTION

The School District of Palm Beach County

Project Name:

SDPBC Project No.:

SECTION 32 18 16.13  
ARTIFICIAL TURF PLAYGROUND PROTECTIVE SURFACING

PART 1 GENERAL

1.1 SECTION INCLUDES

- A. Requirements for installation of a protective surfacing system at play areas equipped with play equipment, the protective surfacing system shall include:
1. Synthetic turf top surface
  2. Synthetic granular material or granular rubber material in a layer below the synthetic turf, or a closed cell polyurethane foam layer below the synthetic turf.
  3. Geotextile layer between the granular material or closed cell foam and the rock layer.
  4. Properly placed rock layer below the synthetic granular material
  5. Geotextile layer between the rock layer and the sub-grade.
  6. Properly prepared soil sub-grade under the rock layer
  7. Concrete containment curb around the system
  8. Synthetic nailing strip around the interior of the curbing
  9. Provisions for removal of storm water from the system and transmission of same to the on-site storm water management system.

1.2 REGULATORY REQUIREMENTS

- A. The protective surfacing system shall provide:
1. Fall protection as required by Federal and State Statutes, Standards, Regulations, and reference materials noted herein.
  2. Accessibility as required by Federal and State Statutes, Standards, and Regulations.
  3. An integral suppression from harmful biological growth including bacterium, molds, fungi, viruses, and any other pathogenic organism.
    - a. Integral shall mean that substances are directly incorporated into the manufacture of the various system components for the purpose identified herein, as opposed to substances applied to the finished system after construction.
    - b. Integral shall alternately mean that the substance naturally resists harmful biological growth in its native, as-manufactured state.

1.3 REFERENCE DOCUMENTS

- A. Guide to ADA Accessibility: Guidelines for Play Areas (May 2001)
- B. Florida Building Code Section 423, State Requirements for Educational Facilities
- C. Florida Building Code -Accessibility
- D. ASTM F1487 - Standard Consumer Safety Performance Specification for Playground Equipment for Public Use
  1. Compliance with this standard must be third party certified by the International Play Equipment Manufacturer's Association (IPEMA)
- E. ASTM F1292 - Standard Specification for Impact Attenuation of Surface Material Within the Use Zone of Playground Equipment
  1. Compliance with this standard must be third party certified by the International Play Equipment Manufacturer's Association (IPEMA)

The School District of Palm Beach County

Project Name:

SDPBC Project No.:

- F. District Master Specifications: Section 03 30 00, Cast-in-Place Concrete and Section 33 40 00, Storm Drainage Utilities

#### 1.4 SUBMITTALS

- A. The Contractor shall furnish to the District the manufacturers' literature and data for all materials installed under this section for approval by the District prior to purchasing or installation.
  - 1. Standard submittals shall include but not be limited to:
    - a. A list of playground equipment components with catalog prices
    - b. 3-dimensional playground layout drawing
    - c. 2-dimensional playground layout drawing
  - 2. This submittal shall also include a scaled site plan that shows the limits of the protective surface system installation, the placement of play equipment within the protective surface limits, and a 12-foot wide clear area around the limits of the protective surface system.
    - a. Verify the 12-foot clear limits through site inspection and use of original Facility as built or construction documents.
  - 3. Submittals shall also include a product mock-up that shows a complete cross-section of the proposed artificial turf section, from the turf through the fall protection layer and drain rock.
    - a. The mock-up will be provided in a clear plastic container that measures 12 inches square, minimum.
    - b. The mock-up will include examples of all seams within construction materials, including the artificial turf, geotextile, and fall protection layers.

#### 1.5 RELATED DOCUMENTS

- A. General provisions of the purchase Contract as provided by others in the District.

#### 1.6 WARRANTY

- A. The system components and installation shall have a minimum one-year warranty covering 100% of all manufacturers' or installation defects.
  - 1. The Contractor providing installation shall immediately repair all defects and separately address any issues with the various component manufacturers. Uninterrupted use of the facilities is critical for proper District operations.
- B. Other individual component warranties, as required of the manufacturer, listed in Part 2.

#### 1.7 LEED COMPLIANCE

- A. The District has determined that projects shall be constructed complying with Leadership in Energy and Environmental Design (LEED) requirements as promulgated in the document titled: LEED Reference Guide for Green Building Design and Construction, For the Design, Construction and Major Renovations of Commercial and Institutional Buildings, Including Core & Shell and K-12 School Projects, 2009 Edition.
- B. The District goal is LEED Silver Certification for all major projects. Certification is not required for small projects consisting only of playground construction.
- C. At a minimum, investigate the potential LEED compliance areas as listed below for construction in accordance with this specification.
  - 1. MR Credit 4 – Recycled Content

The School District of Palm Beach County

Project Name:

SDPBC Project No.:

## 2. MR Credit 5 – Regional Materials

### PART 2 PRODUCTS

#### 2.1 General

- A. Product ASTM standard compliance must be third party certified by the International Play Equipment Manufacturer's Association (IPEMA).
- B. Rock or natural granular mineral materials shall be obtained from virgin sources and not be from recycled construction materials. All rock or natural granular materials shall be free of metallic or sharp edged glass-like materials.
- C. All manufactured materials shall be completely free of lead or lead compounds.

#### 2.2 SYNTHETIC TURF

- A. The synthetic turf shall be Endura Ultra RSIFLTK2-PB or equal. The required properties are:
  - 1. Pile weight – 43 oz. / sq. yd
  - 2. Face yarn type – Polyethylene monofilament with textured nylon mono thatch layer
  - 3. Yarn count – Primary, 5000/4; Secondary, 4200/8
  - 4. Pile height (tufted) – 1-3/4 inch (pre-finished)
  - 5. Color – Verde
  - 6. Construction – Broadloom tufted, dual yarn, same row
  - 7. Tufting gauge – 3/8 inch
  - 8. Primary backing – 6.0 oz/sq yd polypropylene, polyester, and fiber backing
  - 9. Secondary backing – 50 oz/sq yd urethane
  - 10. Tertiary backing – 3.5 oz/sq yd geotextile fleece
  - 11. Total product weight – 103 oz/sq yd plus/minus 2 oz/sq yd
  - 12. Finished roll width – 15 feet
  - 13. Finished roll length – up to 240 feet
  - 14. Anti-microbial yard – 50% by weight
- B. The turf shall be rated by independent testing from a nationally certified testing agency as complying with a minimum drop height of 12-feet in accordance with ASTM F1292.
- C. The turf shall be rated by an independent testing from a nationally certified testing agency as complying with accessibility in accordance with ASTM F1951.

#### 2.3 SYNTHETIC GRANULAR MATERIAL / RUBBER GRANULAR MATERIAL

- A. The synthetic granular material or rubber granular material shall be GTR SOFT-COVER or a similar product manufactured specifically for playground applications.
  - 1. The granular product shall be completely steel-free and sized between 3/8 and 1/8 inch in size.
    - a. The granular product may be produced from used automobile tires.
  - 2. A six-inch thick layer of the granular product shall be rated by independent testing from a nationally certified testing agency as complying with a minimum drop height of 12 feet in accordance with ASTM F1292.

#### 2.4 CLOSED CELL POLYURETHANE FOAM PAD

The School District of Palm Beach County

Project Name:

SDPBC Project No.:

- A. The pad shall be Polygreen Foam Playground Pad as manufactured by United Sustainable Surfaces of America, or pre-approved equal.
  - 1. The pad made from 100% recycled, non-contaminated post-industrial cross-link closed-cell polyethylene foam.
  - 2. The proposed layer thickness of the foam product shall be rated by independent testing from a nationally certified testing agency (IPEMA) as complying with a minimum drop height of 12 feet in accordance with ASTM F 1292.

## 2.5 GEOTEXTILE

- A. Geotextile shall be Mirafi S600 nonwoven polypropylene material as manufactured by TenCate Geosynthetics North America, or a pre-approved equal. The required material properties are:
  - 1. Grab tensile strength (ASTM D4632) – 160 pounds (ultimate) at 50% elongation.
  - 2. Trapezoidal tear strength (ASTM D4533) – 65 pounds.
  - 3. CBR puncture strength (ASTM D6241) – 450 pounds.
  - 4. UV resistance after 500 hours (ASTM D4355) – 80% strength.
  - 5. Permittivity (ASTM D4491) – 1.5 sec<sup>-1</sup>
  - 6. Flow Rate (ASTM D4491) – 110 gal/min/sq ft

## 2.6 ROCK LAYER

- A. The rock layer shall be prepared using FDOT number 57 or number 4 stone.
  - 1. Minimum layer thickness shall be four inches.
  - 2. Rock layer shall be mechanically tamped to ensure minimal settlement and maintenance of uniform layer thickness and surface slope after construction.

## 2.7 COMPACTED SUBGRADE

- A. The compacted sub-grade density shall be at least 95% of T-99.
  - 1. The minimum layer thickness shall be six inches.

## 2.8 CONCRETE CURBING

- A. The concrete curbing shall be manufactured using a design mix that will produce a minimum 28-day compressive strength of 3,000 psi.

## 2.9 SYNTHETIC NAILING STRIP

- A. The synthetic nailing strip shall be manufactured from recycled plastic containers.
  - 1. Use Poly-tuf HDPE Dimensional Plastic Lumber or equivalent product.
    - a. Size shall be equal to dimensional 2x4 lumber.
  - 2. Allow spacing between sections of plastic lumber to account for the relatively large coefficient of thermal expansion.

## 2.10 FASTENERS

- A. All fasteners shall be manufactured using stainless steel or another material with similar corrosion and natural bacteriological resistance.
  - 1. Fasteners shall include nails, staples, bolts, screws, nuts, washers and other similar manufactured objects.

The School District of Palm Beach County

Project Name:

SDPBC Project No.:

- a. Tapcon self-tapping stainless steel concrete anchors or equivalent.
- b. Rapid or Arrow 304 stainless steel staples for fastening synthetic turf to nailer strip.

### PART 3 EXECUTION

#### 3.1 GENERAL

- A. Provide a fall protection assembly as generally shown in Exhibit 1, which appears at the end of this section.

#### 3.2 SEAMS

- A. All turf material seams, which are field fabricated between individual rolls of turf material, shall be made using Velcro and glue or a similar process that produces a full strength seam between rolls.
- B. All turf material seams around equipment supports shall be completely sealed to the support and have no open spaces or other defects that form an attractive nuisance for students to pull that seam apart beginning at the defect.
  1. All seams at equipment supports shall be uniform in appearance.
  2. Seams at supports shall comply with Exhibit 2, which appears at the end of this section.

#### 3.3 FASTENING

- A. Fasten synthetic wood nailing strip to concrete curbing using stainless steel self-tapping fasteners.
  1. Use fastener spacing as needed to meet anticipated working loads imparted from the synthetic turf. Confirm working loads with turf manufacturer or provide fastener spacing such that the turf will tear before the fasteners will pull from the concrete.
- B. Fasten synthetic turf to the synthetic wood nailing strip using stainless steel staples.
  1. Staple spacing as recommended by the turf manufacturer or calculated to exceed the turf strength as noted above.
  2. The turf edge treatment shall be as specified by the turf manufacturer.
- C. Fasteners shall be attached to concrete 14 or more days after the concrete has been placed.

#### 3.4 CONCRETE PLACEMENT

- A. Place concrete in accordance with DMS 03 30 00.
  1. Control joints will be placed at five foot intervals, maximum longitudinal spacing and will be saw cut, minimum 6 inch depth, joint shall be made within 24 to 60 hours after concrete placement.
  2. Place all expansion joints at one side of all corners and at 50 foot maximum longitudinal spacing.

#### 3.5 PLAY EQUIPMENT FOUNDATIONS

- A. Play equipment foundations shall be prepared and placed in accordance with the play equipment manufacturer's requirements.
  1. Where foundations require use of cast-in-place concrete, the concrete and reinforcing steel shall comply with the specifications provided herein.

The School District of Palm Beach County

Project Name:

SDPBC Project No.:

### 3.6 PERIODIC INSPECTION

- A. Periodic inspection of construction will be provided by the SDPBC at the following points:
  - 1. When formwork and reinforcing steel has been placed and assembly is ready to receive concrete.
  - 2. When subgrade has been compacted, play equipment foundations have been placed, and synthetic nailer has been attached to the concrete curbing.
- B. All inspection comments must be resolved and re-inspection may be required.

### 3.7 SITE RESTORATION

- A. The Work area shall be completely restored to the sole satisfaction of the District without additional payment to the Contractor.
  - 1. All construction equipment, materials, supplies, temporary supports and other appurtenant items shall be completely removed from the school site.
  - 2. All grassed areas and landscaping shall be restored to pre-construction conditions unless otherwise specified by the District.

### 3.8 FINAL INSPECTION

- A. A final inspection shall be performed by the District's Department of Risk Management. A Certified Playground Inspector (CPI) will observe the completed project.
  - 1. All final inspection comments shall be resolved to the sole satisfaction of the District CPI without additional compensation.
  - 2. The Contractor may, from time to time, request informal inspections by the CPI to verify that the general intent of the project documents is being met. CPI inspections shall not replace the required Building Department inspections.

*(NOTE – EXHIBIT 1 AND EXHIBIT 2 APPEAR ON THE FOLLOWING PAGES)*

The School District of Palm Beach County

Project Name:

SDPBC Project No.:

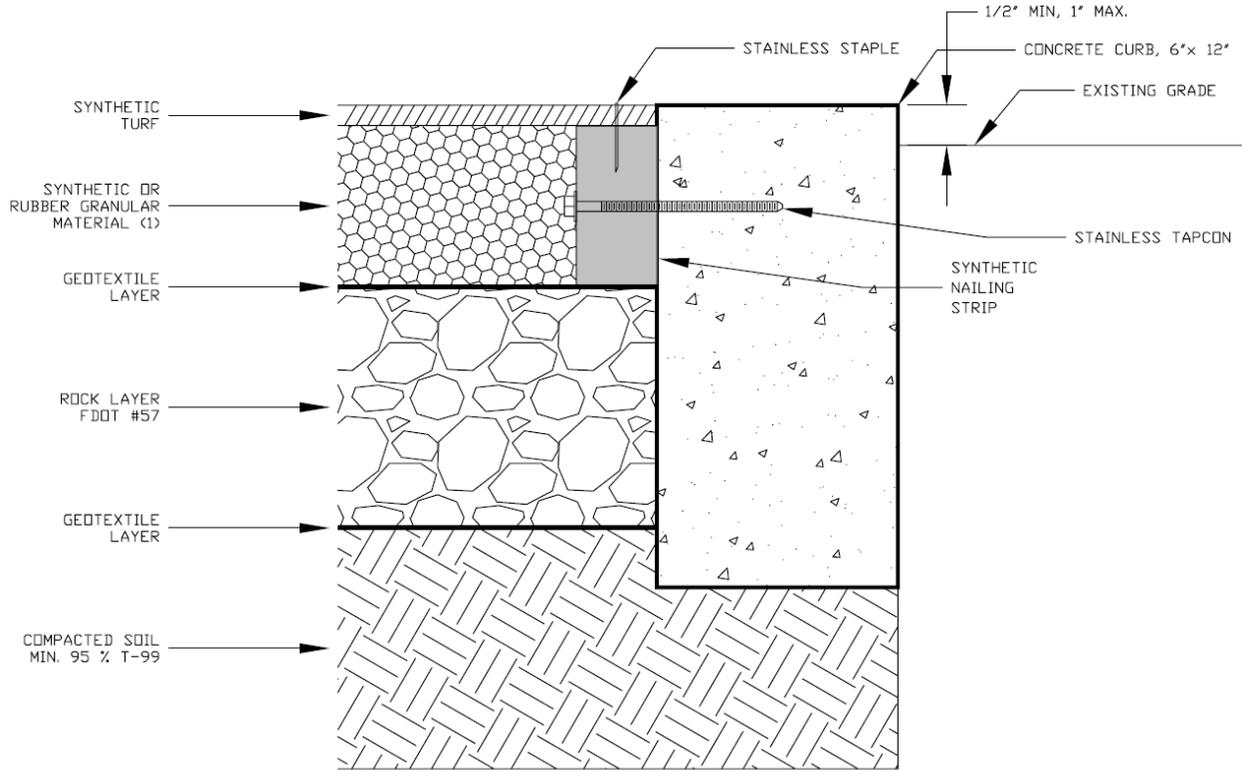

(1) CONTRACTOR MAY SUBSTITUTE MANUFACTURED PADDING MATERIAL PER SPECIFICATION PARAGRAPH 2.4

EXHIBIT 1

The School District of Palm Beach County

Project Name:

SDPBC Project No.:

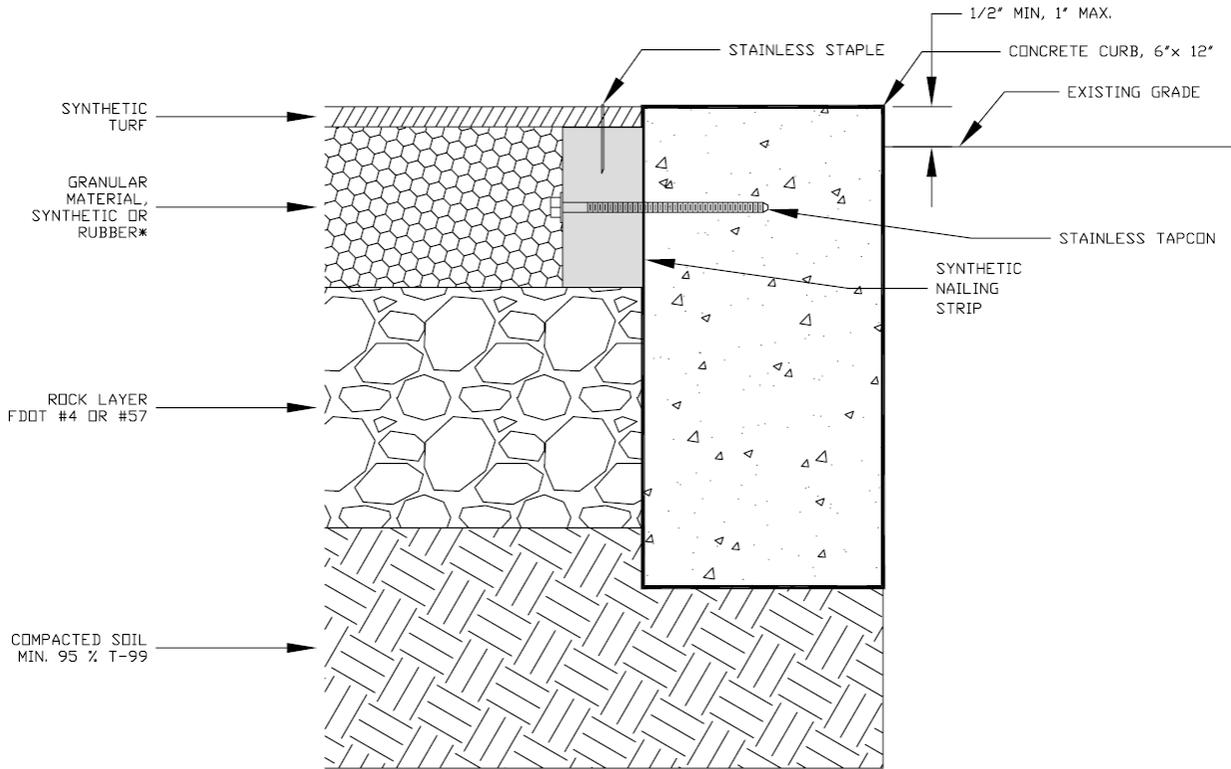

\* CONTRACTOR MAY SUBSTITUTE MANUFACTURED PADDING MATERIAL PER SPECIFICATION PARAGRAPH 2.2.B.

EXHIBIT 1

The School District of Palm Beach County

Project Name:

SDPBC Project No.:

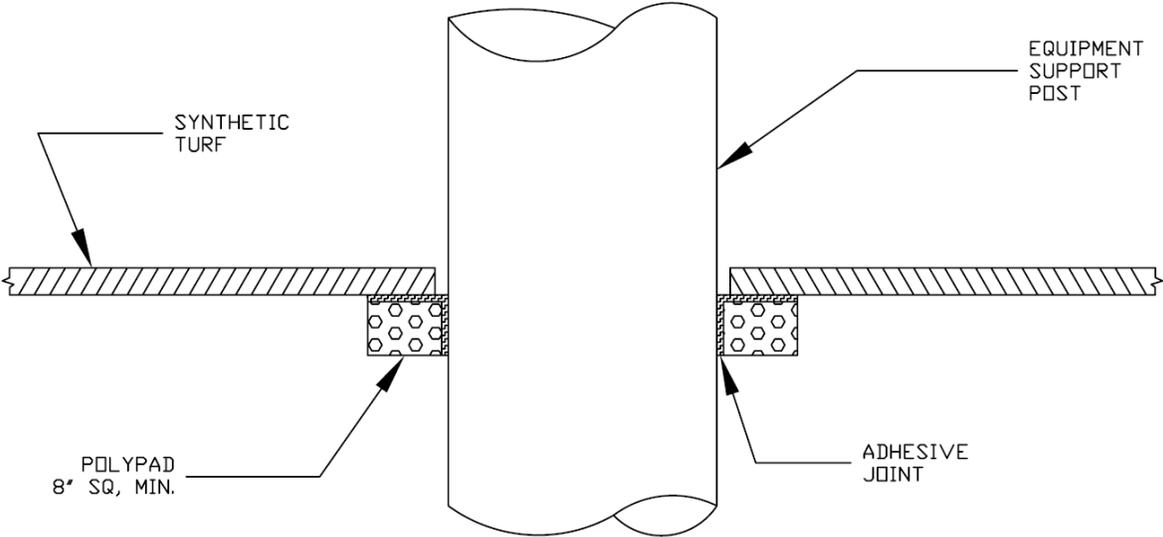

- NOTES:
1. POLYPAD SHALL BE A POLYETHYLENE PAD BLENDED WITH SOME RECYCLED POLYOLEFIN MATERIAL, 1 INCH THICK. THE PAD MATERIAL SHALL HAVE A MINIMUM TEAR RESISTANCE OF 35 POUNDS PER INCH, DETERMINED IN ACCORDANCE WITH ASTM D3575. THE PAD SHALL BE COATED WITH A SUITABLE BINDER SO THE ADHESIVE WILL BOND THE PAD TO THE OTHER MATERIALS.
  2. ADHESIVE SHALL BE LOCTITE PL 400.
  3. EQUIVALENT MATERIALS MAY BE PROVIDED AND WILL BE SUBJECTED TO A FIELD PERFORMANCE TEST TO VERIFY EQUIVALENCY. MATERIALS THAT FAIL THE FIELD TEST WILL BE COMPLETELY REPLACED AT NO ADDITIONAL COST TO THE DISTRICT.

EXHIBIT 2

END OF SECTION

SCHOOL DISTRICT OF PALM BEACH COUNTY  
PURCHASING DEPARTMENT

May 20, 2015

ADDENDUM NO. 1

INVITATION TO BID NO. 15C – 32B

TITLE: TERM CONTRACT FOR PLAYGROUND EQUIPMENT, OUTDOOR FITNESS EQUIPMENT, SURFACING, FITNESS TRAILS AND FABRIC SHADE STRUCTURES

RETURN DATE: May 27, 2015 - 2:00 P.M. EST

This addendum modifies the above listed Invitation to Bid as follows:

Add to Read:

The Beneficial Interest and Disclosure of Ownership Affidavit was omitted from the original bid packet documents. This document has now been uploaded to Demandstar, please download this document and include in your bid packet submittal.

  
\_\_\_\_\_  
Morris Simpson, Purchasing Agent

  
\_\_\_\_\_  
Genell McMann, Purchasing Manager

Posting of Conditions/Specifications

This Addendum will be posted for review by interested parties, at DemandStar.com on the date of the Addendum electronic mailing and will remain posted for a period of 72 hours. Failure to file a protest on any changes to the specifications contained in the Addendum within the time prescribed in section 120.57 (3) Florida Statutes, will constitute a waiver of proceedings under Chapter 120 Florida Statutes, and applicable School Board rules, regulations and policies.

Any person who files an action protesting the specifications contained in this Addendum, pursuant to Section 120.57(3)(b), Florida Statutes shall post with the Purchasing Department, at the time of filing the formal written protest, a bond secured

by an acceptable surety company in Florida payable to the School Board of Palm Beach County in an amount equal to 1 percent (1%) of the total estimated contract value, but not less than \$500 nor more than \$5,000. Bond shall be conditioned upon the payment of all costs that may be adjudged against the protester in the administrative hearing in which the action is brought and in any subsequent appellate court proceeding. In lieu of a bond, a cashier's check, certified bank check, bank certified company check or money order will be acceptable form of security. If, after completion of the administrative hearing process and any appellate court proceedings, the Board prevails, it shall recover all costs and charges included in the final order of judgment, including charges by the Division of Administrative Hearings. Upon payment of such costs and charges by the protester, the protest security shall be returned.



THE SCHOOL DISTRICT OF PALM BEACH COUNTY  
**Beneficial Interest and Disclosure of Ownership Affidavit**

Bid No. 15C-32B Project No./ Title Playground Equipment, Outdoor Fitness Equipment, Surfacing, Fitness Trails, and Fabric Shade Structures

Corporate Name \_\_\_\_\_ Tax FEIN No. \_\_\_\_\_

Before me, the undersigned authority, personally appeared, \_\_\_\_\_, ("Corporate Representative") this \_\_\_\_\_ day of \_\_\_\_\_, 20 \_\_, who, first being duly sworn, as required by law, subject to the penalties prescribed for perjury, deposes and says:

- 1) Corporate Representative has read the contents of this Affidavit, has actual knowledge of the facts contained herein, and states that the facts contained herein are true, correct, and complete.
- 2) The following is a list of every "person" (as defined in Section 1.01(3), Florida Statutes to include individuals, children firms, associates, joint adventures, partnerships, estates, trusts, business trusts, syndicates, fiduciaries, corporations and all other groups and combinations) holding 5% or more of the beneficial interest in the disclosing entity: (If more space is needed, attach separate sheet)

A. Persons or corporate entities owning 5% or more:

Name	Address	Percentage

B. Persons or corporate entities who hold by proxy the voting power of 5% or more:

Name	Address	Percentage

C. Stock held for others and for whom held:

1. Name / 2. From Whom Held	Address	Percentage
1. _____		
2. _____		
1. _____		
2. _____		
1. _____		
2. _____		

CORPORATE REPRESENTATIVE

By: \_\_\_\_\_

**SWORN TO** and subscribed before me this \_\_\_\_\_ day of \_\_\_\_\_, 20 \_\_, by \_\_\_\_\_ Such person(s) (Notary Public must check applicable box).

is/are personally known to me.  produced a current driver license(s).  produced \_\_\_\_\_ as identification.

(NOTARY PUBLIC SEAL)

\_\_\_\_\_  
Notary Public

\_\_\_\_\_  
(Print, Type or Stamp Name of Notary Public)

**THE SCHOOL DISTRICT OF PALM BEACH COUNTY  
PURCHASING DEPARTMENT  
3300 Forest Hill Boulevard, Suite A-323  
West Palm Beach, FL 33406-5813**

**INVITATION TO BID  
15C-32B  
Bidder Acknowledgement**

**Vendor Name:**

**Vendor Mailing Address:**

**E-Mail Address:**

**Area Code / Telephone Number:**

**Toll-Free Telephone Number:**

**Fax Number:**

**Web Address:**

**FEID No. or SS #:**

**Delivery                                      calendar days after receipt of order:**

**ANTI-COLLUSION**

By electronically submitting your bid, the bidder certifies that they have not divulged, discussed or compared their bid with other bidders and have not colluded with any other bidder or parties to a bid whatever. No premiums, rebates or gratuities permitted either with, prior to, or after any delivery of material. Any such violation will result in the cancellation and/or return of materials (as applicable) and the removal from the bid lists for the School District of Palm Beach County, Florida and I hereby certify that I have read and understand the requirements of this Invitation to Bid and that I am duly authorized to execute this offer document and any contract(s) and/or other transaction by award of this bid.

**BID CERTIFICATION**

I further certify that I have read the entire contents of this Invitation to Bid document and agree to full, complete and unconditional acceptance of the contents of this Invitation to Bid and all appendices and the contents of any Addendum released hereto. I further certify that by virtue of executing and returning this Bidder Acknowledgement Form, I am submitting the following information as this company's response.

**Name of Representative Submitting Bid :**

**Title of Company Representative:**

**Date:**

### 15C-32B – Bid Summary

<b>Item 1</b>	<b>Playground Equipment And Outdoor Fitness Equipment</b> <u>Firm Percentage Discount</u> <ul style="list-style-type: none"> <li>Will be deducted from the catalog list prices</li> <li>Bidders must bid a single fixed percentage discount, ex. 12% is acceptable; 11.075% is not</li> <li>The District will accept a discount of 0%.</li> </ul> <u>Freight Charges:</u> <ul style="list-style-type: none"> <li>All freight charges are to be prepaid by successful bidders and added to the invoice</li> <li>The School District will only pay actual freight charges</li> <li>It is further agreed by all vendors signing this bid proposal that title to all items ordered, remain with the vendor until received and accepted by the School District</li> <li>Vendor is required to file all claims for damages/shortages etc.</li> </ul>	
	<b>List the Playground Equipment Manufacturer(s) and the Outdoor Fitness Equipment Manufacturer(s) you represent</b>	<b>Fixed % Percentage Discount off List Price</b>
<b>Item 2.</b>	<b>Installation of Playground and Outdoor Fitness Equipment</b>	<b>Fixed Percentage</b>
	Cost will be based on a firm fixed percentage of the equipment cost (the total after discount has been taken but before freight has been added)	
<p><b>NOTE:</b>                  If bidding to only supply Playground and/or Outdoor Fitness Equipment,                  • you must list your certified installer below                      <b>AND</b>                  • Your certified installer must submit a bid for installation                      <b>AND</b>                  • Your certified installer must be awarded a contract for installation                  in order for you to be awarded to provide playground and/or outdoor fitness equipment</p>		
<b>Playground and Outdoor Fitness Equipment Installer's Company Name (if other than self):</b>		

<b>Item 3.</b>	<b>Poured In Place (PIP) Surfacing for Playgrounds and Outdoor Fitness Equipment</b>						
	<ul style="list-style-type: none"> <li>• Poured In Place (PIP) surfacing must be IPEMA Certified &amp; ADA compliant</li> <li>• Price must be stated per square foot and price must include all materials, adhesives or sub-bases</li> </ul>						
<b>List Manufacturer:</b>							
Critical Fall Height	3'	4'	5'	6'	7'	8'	10'
<b>3a)</b>							
Size	<b>Cost Per Sq Ft</b>	<b>Cost Per Sq Ft</b>	<b>Cost Per Sq Ft</b>	<b>Cost Per Sq Ft</b>	<b>Cost Per Sq Ft</b>	<b>Cost Per Sq Ft</b>	<b>Cost Per Sq Ft</b>
Up to 1,000 Sq Ft							
1,000 to 3,000 Sq Ft							
Over 3,000 Sq Ft							
<b>3b) Installation of PIP surfacing charge if it is not included in the prices above</b>						\$ _____ per Sq Ft	

<b>Item 4.</b>	<b>Artificial Turf installed on a playground (with fall protection)</b>						
	<ul style="list-style-type: none"> <li>• Must be IPEMA certified and ADA compliant</li> <li>• Price stated must be per square foot and price must include all materials, adhesives, etc.</li> </ul>						
<b>List Manufacturer:</b>							
Critical Fall Height	3'	4'	5'	6'	7'	8'	10'
<b>4a) Cost Per Sq Ft</b>							
Size	<b>Cost Per Sq Ft</b>	<b>Cost Per Sq Ft</b>	<b>Cost Per Sq Ft</b>	<b>Cost Per Sq Ft</b>	<b>Cost Per Sq Ft</b>	<b>Cost Per Sq Ft</b>	<b>Cost Per Sq Ft</b>
Up to 1,000 Sq Ft							
1,000 to 3,000 Sq Ft							
Over 3,000 Sq Ft							
<b>4b) Installation of Artificial Turf charge if it is not included in the prices above</b>						\$ _____ per Sq Ft	

<b>Item 5.</b>	<b>Artificial Turf – Provide and install where fall protection is NOT required</b>						
<b>List Manufacturer:</b>							
<b>5a)</b>	Cost Per Sq Ft	Cost Per Sq Ft	Cost Per Sq Ft	Cost Per Sq Ft	Cost Per Sq Ft	Cost Per Sq Ft	Cost Per Sq Ft
Size							
Up to 1,000 Sq Ft							
1,000 to 3,000 Sq Ft							
Over 3,000 Sq Ft							
<b>5b) Installation of Artificial Turf <u>Without</u> fall protection fee if installation is not included in the prices above</b>						\$ _____ per Sq Ft	

<b>Item 6.</b>	<b>Engineered Wood Fiber</b> Must comply with ASTM and be IPEMA certified Quotes will be requested when needed <b>Indicate if you can provide (Yes or No)</b>	___ Yes or ___ No
<b>List the Manufacturer:</b>		

<b><u>Site Preparation:</u></b>		
<ul style="list-style-type: none"> <li>All bidders for installation must complete this section in order to be awarded as the pool of pre-qualified vendors for all projects under this bid</li> <li>Provide firm prices for the following line items</li> <li>Prices must be submitted in the same unit of measure as listed below:</li> </ul>		
<b>Item 7.</b>	Dig-out/ Excavation Price must include removal and disposal	\$_____ per sq. ft.
<b>Item 8.</b>	Sand, clean & suitable for playgrounds Price must include delivery and placement	\$_____ per cubic yard
<b>Item 9.</b>	Clean Fill Delivered and graded	\$_____ per sq. ft.
<b>Item 10.</b>	Concrete – provide and install All concrete shall comply with DMS & FI. Building Code Includes concrete for sidewalks There shall be no additional fee for getting the concrete to the site	
<b>10a.</b>	4" Wide X 12" Deep for PIP surfacing	\$_____ per sq. ft.
<b>10b.</b>	6" Wide X 12" Deep for artificial turf	\$_____ per sq. ft.
<b>Item 11.</b>	Recycled playcurb borders Provide and install	\$_____ per linear ft.
<b>Item 12.</b>	Aluminum ADA handrails Provide and install	\$_____ per linear ft.
<b>Item 13.</b>	Provide Utility Locates	\$_____ each
<b>Item 14.</b>	Provide signed sealed engineered drawings	\$_____ per job

<b><u>Additional Site Preparation Items:</u></b>	
Vendors may be required to provide quotations for optional items such as, but not limited to: <ul style="list-style-type: none"> <li>removal and/or relocation of existing playground equipment</li> <li>replacement parts for playground components</li> <li>tree trimming or removal</li> <li>excavation/demucking for sites where rock or muck is found</li> <li>provide and lay sod in area surrounding playground where sand was (sod replacement for site restoration shall be done at no charge to the District)</li> </ul>	

<b>Item 15</b>	<p><b><u>Repair, Recap and/or Replace Playground Surfacing</u></b>                  Bidder wishes to be in the pool of pre-qualified vendors and be eligible to respond to Request For Quotes (RFQ) for projects to Repair, Recap and/or Replace Playground Surfacing</p> <p style="text-align: center;"><b>Mark an "X" in the space provided</b></p>	<p>___ YES</p>
----------------	---	----------------

<b>Item 16</b>	<p><b><u>Fabric Shade Structures :</u></b>                  This will establish a pool of pre-qualified vendors to furnish and install fabric shade structures as requested in accordance with the terms, specifications, District Master Specs and conditions set forth in this bid</p> <p><b><i>To be in the pool of pre-qualified vendors and be eligible to respond to Request For Quotes (RFQ) for Fabric Shade Structures, you must mark an "X" in the box by "YES"</i></b></p>	
----------------	---	--

NOTE:  
 If bidding to only supply Shade Structures

- you must list your certified installer below

**AND**

- Your certified installer must submit a bid for installation

**AND**

- Your certified installer must be awarded a contract to install this item in order for you to be awarded for this item

<b>Item 16</b>	<b><u>Provide Shade Structures</u></b>	___ YES	___ NO
----------------	--	---------	--------

<b>Manufacturer:</b>	
<b>Installer if other than self:</b>	

<b>Item 17.</b> <b><u>Install Shade Structure</u></b>	___ YES	___ NO
--	---------	--------

<p><b>Item 18. <u>Provide Fitness Trails (equipment/stations &amp; surfacing)</u></b></p> <p>This will establish a pool of pre-qualified vendors to furnish and install Fitness Trails as requested in accordance with the terms, specifications and conditions set forth in this bid and all applicable codes and standards.</p> <p><b><i>To be in the pool of pre-qualified vendors and be eligible to respond to Request For Quotes (RFQ) for Fitness Trails, you must mark an "X" in the box by "YES"</i></b></p>		
<p>NOTE: If bidding to only supply Fitness Trail Equipment/Stations,</p> <ul style="list-style-type: none"> <li>• you must list your certified installer below</li> </ul> <p style="text-align: center;"><b>AND</b></p> <ul style="list-style-type: none"> <li>• Your certified installer must submit a bid for installation</li> </ul> <p style="text-align: center;"><b>AND</b></p> <ul style="list-style-type: none"> <li>• Your certified installer must be awarded a contract for the installation in order for you to be awarded to provide Fitness Trail Equipment/Stations</li> </ul>		
<b>Item 18</b>	<b>Provide Fitness Trail Equipment</b>	<input type="checkbox"/> YES <input type="checkbox"/> NO
<b>Manufacturer:</b>		
<b>Installer if other than self:</b>		
<b>Item 19.</b>	<b><u>Install Fitness Trails and Surfacing</u></b>	<input type="checkbox"/> YES <input type="checkbox"/> NO

<p><b>Item 20. Replacement Parts for Playground or outdoor fitness equipment and supplies such as sealer for poured in place surfacing:</b>                      List the Playground Equipment Manufacturer(s) and the Outdoor Fitness Equipment Manufacturer(s) you are authorized to sell replacement parts or supplies for and provide a firm percentage discount to be taken off list price or mark "Yes" to provide quotes if you cannot give a single fixed discount off list price (Refer to Bid Specifications)</p>	<p><b>Fixed Percentage Discount off List Price</b></p>	<p><b>Cannot give firm discount but will provide quotes when requested (Mark "Yes")</b></p>
<p>Delivery Business Days After Receipt of Order (ARO):</p>	<p>_____ business days</p>	
<p>Address of facility where parts will be shipped from:</p>		

<p><b>Item 21</b></p>	<p><b><u>Recoat existing PVC playground equipment decks</u></b>                      Provide on-site service to restore/renew decks that are worn and/or have coating that is peeling                      Includes cleaning, priming and recoating in compliance with all applicable standards and codes                      Bidder wishes to be in the pool of pre-qualified vendors and be eligible to respond to Request For Quotes (RFQ) for single jobs or larger projects to  <b>Mark an "X" in the space provided</b></p>	<p>___ YES</p>
-----------------------	--	----------------

<p><b>Vendor Name:</b></p>	
----------------------------	--

**This form must be downloaded, completed and uploaded to DemandStar with your bid response**

**Bid 15C-32B**

**AREA REPRESENTATIVE**

Please list the contact for this bid

Vendor Name:	
Area Representative:	
Email Address:	
Cell Phone Number:	
Office Number (With extension)	

**This form must be downloaded, completed and uploaded to DemandStar with your bid response**

SCHOOL DISTRICT OF PALM BEACH COUNTY  
PURCHASING DEPARTMENT

DEBARMENT CERTIFICATION

CERTIFICATION REGARDING DEBARMENT, SUSPENSION,  
INELIGIBILITY AND VOLUNTARY EXCLUSION  
LOWER TIER COVERED TRANSACTIONS

This certification is required by the regulations implementing Executive Order 12549, Debarment and Suspension, 7 CFR Part 3017, Section 3017.510, Participants' responsibilities. The regulations were published as Part IV of the January 30, 1989, Federal Register (pages 4722-4733). Copies of the regulations may be obtained by contacting the Department of Agriculture agency with which this transaction originated. (Before Completing Certification, Read Instructions on Following Page)

- (1) The prospective lower tier participant certifies, by submission of this proposal, that neither it nor its principals is presently debarred, suspended, proposed for debarment, declared ineligible, or voluntarily excluded from participation in this transaction by an Federal department or agency.
- (2) Where the prospective lower tier participant is unable to certify to any of the statements in this certification, such prospective participants shall attach an explanation to this proposal.

Organization Name: \_\_\_\_\_

Solicitation Number or Project Name: Bid 15C-32B \_\_\_\_\_

Name of Authorized Representative: \_\_\_\_\_

Title of Representative: \_\_\_\_\_

Date: \_\_\_\_\_

**INSTRUCTION CERTIFICATIONS**

1. By electronic submission of this form the prospective lower tier participant is providing the certification set out on the reverse side in accordance with these instructions.
2. The certification in this clause is a material representation of fact upon reliance was placed when this transaction was entered into. If it is later determined that the prospective lower tier participant knowingly rendered an erroneous certification, in addition to other remedies available to the Federal Government, the department or agency with which this transaction originated may pursue available remedies, including suspension and/or debarment.
3. The prospective lower tier participant shall provide immediate written notice to the person to which this proposal is submitted if at any time the prospective lower tier participant learns that its certification was erroneous when submitted or has become erroneous by reason of changed circumstances.
4. The terms "covered transaction," "debarred," "suspended," "ineligible," "lower tier covered transaction," "participant," "person," "primary covered transaction," "principal," "proposal," "voluntarily excluded," as used in this clause, have the meanings set out in the Definitions and Coverage section so rules implementing Executive Order 12549. You may contact the person to which this proposal is submitted for assistance in obtaining a copy of those regulations.
5. The prospective lower tier participant agrees by submitting this form that, should the proposed covered transaction be entered into, it shall not knowingly enter into any lower tier covered transaction with a person who is debarred, suspended, declared ineligible, or voluntarily excluded from participation in this covered transaction, unless authorized by the department or agency with which this transaction originated.
6. The prospective lower tier participant further agrees by submitting this form that it will include this clause titled, "Certification Regarding Debarment, Suspension, Ineligibility and Voluntary Exclusion - Lower Tier Covered Transactions," without modification, in all lower tier covered transactions and in all solicitations for lower tier covered transactions.
7. A participant in a covered transaction may rely upon a certification of a prospective participant in a lower tier covered transaction that it is not debarred, suspended, ineligible, or voluntarily excluded from the covered transaction, unless it knows that the certification is erroneous. A participant may decide the method and frequency by which it determines the eligibility of its principals. Each participant may, but is not required to, check the Non-procurement List.
8. Nothing contained in the foregoing shall be construed to require establishment of a system of records in order to render in good faith the certification required by this clause. The knowledge and information of a participant is not required to exceed that which is normally possessed by a prudent person in the ordinary course of business dealings.
9. Except for transactions authorized under paragraph 5 of these instructions, if a participant in covered transaction knowingly enters into a lower tier covered transaction with a person who is suspended, debarred, ineligible, or voluntarily excluded from participation in this transaction, in addition to other remedies available to the Federal Government, the department or agency with which this transaction originated may pursue available remedies, including suspension and/or debarment.

SCHOOL DISTRICT OF PALM BEACH COUNTY  
PURCHASING DEPARTMENT

**EARLY PAYMENT TERMS**

<b>BID NAME/NUMBER:</b> _____ <b>VENDOR NAME:</b> _____
--

If vendor chooses not to participate in Early Payment Terms, please acknowledge by placing N/A here → \_\_\_\_\_.

<b>EARLY PAYMENT:</b> Specify terms and discount for early payment. Check which terms you will be willing to provide for the duration of this contract to the School District.
0.5% 10 net 30 *
0.75% 5 net 30 *

\* Upon receipt of invoice by the School District of Palm Beach County Accounts Payable Department.

**Note:** Updating to these terms will affect all of your District payments. If you choose to revise these terms at a later date, the terms will affect all of your payments from the District.

**PROPOSER'S STATEMENT OF PRINCIPAL PLACE OF BUSINESS**  
*(Must be completed & submitted with each competitive solicitation)*

Name of Proposer: \_\_\_\_\_

Identify the state in which the Proposer has its principal place of business: \_\_\_\_\_

Proceed as follow: **IF** your principal place of business above is located within the State of Florida, the Proposer may sign below and attach to your solicitation. No further action is required. **IF** your principal place of business is outside of the State of Florida the following must be completed by an attorney and returned with your solicitation. Failure to comply shall be considered to be non-responsive to this solicitation.

**OPINION OF OUT-OF-STATE BIDDER'S ATTORNEY ON BIDDING PREFERENCES**

*(To be completed by the Attorney for an Out-of-State Proposer)*

**NOTICE:** Section 287.084(2), Fla. Stat., provides that "a vendor whose principal place of business is outside this state must accompany any written bid, proposal, or reply documents with a written opinion of an attorney at law licensed to practice law in that foreign state, as to the preferences, if any or none, granted by the law of that state [or political subdivision thereof] to its own business entities whose principal places of business are in that foreign state in the letting of any or all public contracts." See also: Section 287.084(1), Fla. Stat.

**LEGAL OPINION ABOUT STATE BIDDING PREFERENCES**

*(Please Select One)*

\_\_\_\_\_ The Proposer's principal place of business is in the State of \_\_\_\_\_ and it is my legal opinion that the laws of that state **do not grant a preference** in the letting of any or all public contracts to business entities whose principal places of business are in that state.

\_\_\_\_\_ The Proposer's principal place of business is in the State of \_\_\_\_\_ and it is my legal opinion that the laws of that state **grant the following preference(s)** in the letting of any or all public contracts to business entities whose principal places of business are in that state: [Please describe applicable preference(s) and identify applicable state law(s)]:

\_\_\_\_\_  
\_\_\_\_\_  
\_\_\_\_\_

**LEGAL OPINION ABOUT POLITICAL SUBDIVISION BIDDING PREFERENCES**

*(Please Select One)*

\_\_\_\_\_ The Proposer's principal place of business is in the political subdivision of \_\_\_\_\_ and it is my legal opinion that the laws of that political subdivision **do not grant a preference** in the letting of any or all public contracts to business entities whose principal places of business are in that political subdivision.

\_\_\_\_\_ The Proposer's principal place of business is in the political subdivision of \_\_\_\_\_ and the laws of that political subdivision **grant the following preference(s)** in the letting of any or all public contracts to business entities whose principal places of business are in that political subdivision: [Please describe applicable preference(s) and identify applicable authority granting the preference(s)]:

\_\_\_\_\_  
\_\_\_\_\_  
\_\_\_\_\_

Signature of out-of-state Proposer's attorney: \_\_\_\_\_

Printed name of out-of-state Proposer's attorney: \_\_\_\_\_

Address of out-of-state bidder's attorney: \_\_\_\_\_

\_\_\_\_\_

Telephone Number of out-of-state bidder's attorney: (\_\_\_\_) \_\_\_\_ - \_\_\_\_\_

Email address of out-of-state bidder's attorney: \_\_\_\_\_

Attorney's states of bar admission: \_\_\_\_\_

Proposer's Printed Name: \_\_\_\_\_ Signature \_\_\_\_\_

Company Name: \_\_\_\_\_

SCHOOL DISTRICT OF PALM BEACH COUNTY  
PURCHASING DEPARTMENT

**Bid 15C-32B- REFERENCES**

**Vendor Name:** \_\_\_\_\_

This information will be used in the evaluation of this bid.

- Complete the information below
- Notify each reference that we will be contacting them by email and their response will be used in evaluating your company
- School District or Governmental agencies are preferred references
- References shall not be for work performed more than 3 years ago
- You may not list the School District of Palm Beach County as more than one reference

State the type of work you did for each reference from this list of options (list all that apply):

- Provided playground equipment**
- Installed playground or outdoor fitness equipment**
- Provided & installed PIP surfacing**
- Provided & installed artificial turf**
- Provided fabric shade structure**
- Installed fabric shade structure**
- Provided fitness trails**
- Installed fitness trails**

**Reference 1**

<b>School District, Governmental Agency or Company:</b>	
<b>Contact Person:</b>	
<b>Email:</b>	
<b>Phone #:</b>	
<b>Type of work (choose from list above)</b>	
<b>Date work was completed</b>	

**Reference 2**

<b>School District, Governmental Agency or Company:</b>	
<b>Contact Person:</b>	
<b>Email:</b>	
<b>Phone #:</b>	
<b>Type of work (choose from list above)</b>	
<b>Date work was completed</b>	

**Reference 3**

<b>School District, Governmental Agency or Company:</b>	
<b>Contact Person:</b>	
<b>Email:</b>	
<b>Phone #:</b>	
<b>Type of work (choose from list above)</b>	
<b>Date work was completed</b>	

**Reference 4**

<b>School District, Governmental Agency or Company:</b>	
<b>Contact Person:</b>	
<b>Email:</b>	
<b>Phone #:</b>	
<b>Type of work (choose from list above)</b>	
<b>Date work was completed</b>	

**Reference 5**

<b>School District, Governmental Agency or Company:</b>	
<b>Contact Person:</b>	
<b>Email:</b>	
<b>Phone #:</b>	
<b>Type of work (choose from list above)</b>	
<b>Date work was completed</b>	

**This form must be downloaded, completed and uploaded to DemandStar with your bid response**



**THE SCHOOL DISTRICT OF PALM BEACH COUNTY  
Drug-Free Workplace Certification**

Preference must be given to vendors submitting a certification with their bid/proposal certifying they have a drug-free workplace in accordance with Section 287.087, Florida Statutes. This requirement affects all public entities of the State and becomes effective January 1, 1991. The special condition is as follows:

**IDENTICAL TIE BIDS** - Preference shall be given to businesses with drug-free workplace programs. Whenever two or more bids which are equal with respect to price, quality, and service are received by the State or by any political subdivision for the procurement of commodities or contractual services, a bid received from a business that certifies that it has implemented a drug-free workplace program shall be given preference in the award process. Established procedures for processing tie bids will be followed if none of the tied vendors have a drug-free workplace program, a business shall:

- 1) Publish a statement notifying employees that the unlawful manufacture, distribution, dispensing, possession, or use of a controlled substance is prohibited in the workplace and specifying the actions that will be taken against employees for violations of such prohibition.
- 2) Inform employees about the dangers of drug abuse in the workplace, the business's policy of maintaining a drug-free workplace, any available drug counseling, rehabilitation, and employee assistance programs, and the penalties that may be imposed upon employees for drug abuse violations.
- 3) Give each employee engaged in providing the commodities or contractual services that are under bid a copy of the statement specified in subsection (1).
- 4) In the statement specified in subsection (1), notify the employees that, as a condition of working on the commodities or contractual services that are under bid, the employee will abide by the terms of the statement and will notify the employer of any conviction of, or plea of guilty or nolo contendere to, any violation of chapter 893 or of any controlled substance law of the United States or any state, for a violation occurring in the workplace no later than five (5) days after such conviction.
- 5) Impose a sanction on, or require the satisfactory participation in a drug abuse assistance or rehabilitation program if such is available in the employee's community, by any employee who is so convicted.
- 6) Make a good faith effort to continue to maintain a drug-free workplace through implementation of this section.

As the person authorized to sign the statement, I certify that this firm complies fully with the above requirements.

\_\_\_\_\_  
VENDOR'S SIGNATURE

\_\_\_\_\_  
DATE

\_\_\_\_\_  
COMPANYNAME

**Must be executed and returned with attached bid at time of bid opening to be considered.**

**School District of Palm Beach County**  
**MINORITY CERTIFICATION INFORMATION**

**Bid 15C-32B**

\* Check here if N/A: \_\_\_\_\_

Form **must be submitted** with your bid response to **Demandstar.com**

<p>Minority Certification applications are available through the Minority Business Enterprise located at:</p> <p style="padding-left: 40px;">Office of Diversity in Business Practices          School District of Palm Beach County          3300 Forest Hill Boulevard, Suite A-106          West Palm Beach, FL 33406-5871          Phone: (561) 434-8508  <a href="http://www.palmbeachschools.org/mwbe/">http://www.palmbeachschools.org/mwbe/</a></p>								
<p><b>Are you a minority vendor certified by:</b> (Check if appropriate)</p> <p style="padding-left: 40px;">Palm Beach County School District _____</p> <p style="padding-left: 40px;">State of Florida _____</p> <p>If yes, expiration date _____</p> <p>Minority Classification _____</p>								
<p>If you are not a certified minority vendor and intend to sub-contract with a certified minority firm(s), please list the vendors and the estimated dollar value below:</p> <table style="width: 100%; border-collapse: collapse;"> <thead> <tr> <th style="text-align: left; border-bottom: 1px solid black; width: 60%;"><u>Vendor</u></th> <th style="text-align: left; border-bottom: 1px solid black; width: 40%;"><u>Estimated Dollar Value</u></th> </tr> </thead> <tbody> <tr> <td style="border-bottom: 1px solid black;">_____</td> <td style="border-bottom: 1px solid black;">\$ _____</td> </tr> <tr> <td style="border-bottom: 1px solid black;">_____</td> <td style="border-bottom: 1px solid black;">\$ _____</td> </tr> <tr> <td style="border-bottom: 1px solid black;">_____</td> <td style="border-bottom: 1px solid black;">\$ _____</td> </tr> </tbody> </table>	<u>Vendor</u>	<u>Estimated Dollar Value</u>	_____	\$ _____	_____	\$ _____	_____	\$ _____
<u>Vendor</u>	<u>Estimated Dollar Value</u>							
_____	\$ _____							
_____	\$ _____							
_____	\$ _____							

Reminder: **Download all documents, complete them and save as a single PDF document and re-upload them to DemandStar.**

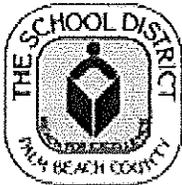

THE SCHOOL DISTRICT OF PALM BEACH COUNTY  
OFFICE OF DIVERSITY IN BUSINESS PRACTICES

# Participation Letter of Intent

Minority/Women Business Enterprise (M/WBE)  Small Business Enterprise (SBE)

Submit completed form to the Senior Project Administrator (SPA). Direct all questions to (561) 434-8508.  
Form must be submitted to Demandstar.com

BID/RFP or Project Name \_\_\_\_\_

BID/RFP or Project # \_\_\_\_\_

Name of Bidder/Construction Manager \_\_\_\_\_

The undersigned intends to perform work with the above project as (check one):

- Individual       Partnership       Corporation       Joint Venture\*

*\*If a joint venture, attach letterhead or other documentation proving relationship.*

The undersigned intends to perform work with the above project as (check one):

- Subcontractor       Subconsultant       Manufacturer       Supplier

The undersigned is:  Certified with the School District of Palm Beach County M/WBE Coordinator

Certified with the State of Florida, Department of General Services (Provisional)

The undersigned is: (MWBE must check one in column 1 and column 2; Column 2. completed by both MWBE or SBE; Column 3 completed by MWBE or SBE if applicable)

**Column 1 (MWBE ONLY)**

**Column 2 (MWBE ONLY)**

**Column 3**

- |  |  |                                 |  |
|--|--|---------------------------------|--|
| <input type="checkbox"/> African American  | <input type="checkbox"/> Native American | <input type="checkbox"/> Female | <input type="checkbox"/> Physically Impaired |
| <input type="checkbox"/> Asian American    | <input type="checkbox"/> American        | <input type="checkbox"/> Male   |  |
| <input type="checkbox"/> Hispanic American |  |                                 |  |

**PARTICIPATION** The undersigned intends to perform the following work in connection with the above project:

Item No.	Division No.	Contract (Trade) Items (Description/Division)	Amount

If the undersigned intends to sub-contract any portion of this subcontract to a non-certified M/WBE or SBE subcontractor, the amount of any such subcontract must be stated \$ \_\_\_\_\_

Name of M/WBE or SBE Subcontracting Firm \_\_\_\_\_

Name and Position (type or print) \_\_\_\_\_

**INTERNAL USE ONLY - ROUTING DISPOSITION**  
 All executed originals of the form must be submitted to the  
 Office of Diversity in Business Practices  
 3300 Forest Hill Blvd., A-106, West Palm Beach, FL 33406-5813

\_\_\_\_\_  
Signature

\_\_\_\_\_  
Date

**HOOE DISTRICT OF PALM BEACH COUNTY  
onsultant, Subcontractor &  
for Participation Services**

1. PROJECT NAME

2. PROJECT NUMBER

3. PHASE (Precon, Demo, Const)

4. TOTAL BID OR CM SERVI

MWBE  SBE  Check One:  Subconsultant  Subcontractor  Vendor  
**\* GMP SUMMARY AMOUNTS (Pre-construction phase fee + Construction phase fee + C**  
Subject to Agreement with the Construction Manager, the Subcontractor firms (minority & i  
below will participate in this project for the Contract (Trade) Items and the dollar amounts s

CONTRACTOR / SUBCONSULTANT / VENDOR NAME	BUDGET (Est. Cost)	CONTRACT AMOUNT	DESCRIPTION	MWBE or SBE (Yes or No)	AMOUNT
				<input type="radio"/> Yes <input type="radio"/> No	
				<input type="radio"/> Yes <input type="radio"/> No	
				<input type="radio"/> Yes <input type="radio"/> No	
				<input type="radio"/> Yes <input type="radio"/> No	
				<input type="radio"/> Yes <input type="radio"/> No	
				<input type="radio"/> Yes <input type="radio"/> No	
				<input type="radio"/> Yes <input type="radio"/> No	
				<input type="radio"/> Yes <input type="radio"/> No	
				<input type="radio"/> Yes <input type="radio"/> No	
				<input type="radio"/> Yes <input type="radio"/> No	
				<input type="radio"/> Yes <input type="radio"/> No	
				<input type="radio"/> Yes <input type="radio"/> No	
				<input type="radio"/> Yes <input type="radio"/> No	

**SUBTOTAL (this page only)>**  
**TOTAL SBE/MWBE Services Participation**  
**TOTAL Non-MWBE/SBE Participation**  
**TOTAL Percentage of Total Bid (Alternates & Change Orders)**

ent as Certified MWBEs/SBEs are certified according to requirements established in the Proposal &  
A copy of the certification and signed Letter of Intent must be attached for each MWBE/SBE. List must  
rity firms.  
ATTACHMENT A  
(Do not t

**contractor &  
in Services**

PROJECT NAME

PROJECT NUMBER

PHASE (Precon, Demo, Const)

TOTAL BID OR CM SERVICE

CONTRACTOR / SUBCONSULTANT / VENDOR NAME	BUDGET (Est. Cost)	CONTRACT AMOUNT	DESCRIPTION	MWBE/SBE (Yes or No)	MWBE ONLY AMOUNT
				<input type="radio"/> Yes <input type="radio"/> No	
				<input type="radio"/> Yes <input type="radio"/> No	
				<input type="radio"/> Yes <input type="radio"/> No	
				<input type="radio"/> Yes <input type="radio"/> No	
				<input type="radio"/> Yes <input type="radio"/> No	
				<input type="radio"/> Yes <input type="radio"/> No	
				<input type="radio"/> Yes <input type="radio"/> No	
				<input type="radio"/> Yes <input type="radio"/> No	
				<input type="radio"/> Yes <input type="radio"/> No	
				<input type="radio"/> Yes <input type="radio"/> No	
				<input type="radio"/> Yes <input type="radio"/> No	
				<input type="radio"/> Yes <input type="radio"/> No	
				<input type="radio"/> Yes <input type="radio"/> No	
				<input type="radio"/> Yes <input type="radio"/> No	
				<input type="radio"/> Yes <input type="radio"/> No	
				<input type="radio"/> Yes <input type="radio"/> No	
				<input type="radio"/> Yes <input type="radio"/> No	
				<input type="radio"/> Yes <input type="radio"/> No	
				<input type="radio"/> Yes <input type="radio"/> No	
				<input type="radio"/> Yes <input type="radio"/> No	
			<b>SUBTOTAL (this page only) &gt;</b>		

ATTACHMENT A

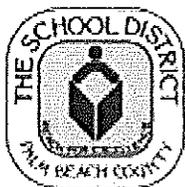

THE SCHOOL DISTRICT OF PALM BEACH COUNTY  
OFFICE OF DIVERSITY IN BUSINESS PRACTICES

# Participation Letter of Intent

Minority/Women Business Enterprise (M/WBE)     Small Business Enterprise (SBE)

Submit completed form to the Senior Project Administrator (SPA). Direct all questions to (561) 434-8508.  
Form must be **submitted to Demandstar.com**

BID/RFP or Project Name \_\_\_\_\_

BID/RFP or Project # \_\_\_\_\_

Name of Bidder/Construction Manager \_\_\_\_\_

The undersigned intends to perform work with the above project as (check one):

Individual     Partnership     Corporation     Joint Venture\*

*\* If a joint venture, attach letterhead or other documentation proving relationship.*

The undersigned intends to perform work with the above project as (check one):

Subcontractor     Subconsultant     Manufacturer     Supplier

The undersigned is:  Certified with the School District of Palm Beach County M/WBE Coordinator

Certified with the State of Florida, Department of General Services (Provisional)

The undersigned is: (MWBE must check one in column 1 and column 2; Column 2. completed by both MWBE or SBE; Column 3 completed by MWBE or SBE if applicable)

**Column 1 (MWBE ONLY)**

**Column 2 (MWBE ONLY)**

**Column 3**

African American     Native American     Female     Physically Impaired  
 Asian American     American     Male  
 Hispanic American

**PARTICIPATION** The undersigned intends to perform the following work in connection with the above project:

Item No.	Division No.	Contract (Trade) Items (Description/Division)	Amount

If the undersigned intends to sub-contract any portion of this subcontract to a non-certified M/WBE or SBE subcontractor, the amount of any such subcontract must be stated \$ \_\_\_\_\_

Name of M/WBE or SBE Subcontracting Firm \_\_\_\_\_

Name and Position (type or print) \_\_\_\_\_

<p><b>INTERNAL USE ONLY - ROUTING DISPOSITION</b> All executed originals of the form must be submitted to the Office of Diversity in Business Practices 3300 Forest Hill Blvd., A-106, West Palm Beach, FL 33406-5813</p>
---

Signature \_\_\_\_\_

Date \_\_\_\_\_

<p>THE SCHOOL DISTRICT OF PALM BEACH COUNTY PURCHASING DEPARTMENT 3300 Forest Hill Boulevard, Suite A-323 West Palm Beach, FL 33406-5813</p>	
<p>INVITATION TO BID 15C-32B Bidder Acknowledgement</p>	
Vendor Name:	Rep Services, Inc.
Vendor Mailing Address:	581 Technology Park, Suite 1009 Lake Mary, FL 32746
E-Mail Address:	kfurman@repservices.com
Area Code / Telephone Number:	407-831-9658
Toll-Free Telephone Number:	N/A
Fax Number:	866-232-8532
Web Address:	www.repservices.com
FEID No. or SS #:	59-2978507
Delivery	20 calendar days after receipt of order:
<b><u>ANTI-COLLUSION</u></b>	
<p>By electronically submitting your bid, the bidder certifies that they have not divulged, discussed or compared their bid with other bidders and have not colluded with any other bidder or parties to a bid whatever. No premiums, rebates or gratuities permitted either with, prior to, or after any delivery of material. Any such violation will result in the cancellation and/or return of materials (as applicable) and the removal from the bid lists for the School District of Palm Beach County, Florida and I hereby certify that I have read and understand the requirements of this Invitation to Bid and that I am duly authorized to execute this offer document and any contract(s) and/or other transaction by award of this bid.</p>	
<b><u>BID CERTIFICATION</u></b>	
<p>I further certify that I have read the entire contents of this Invitation to Bid document and agree to full, complete and unconditional acceptance of the contents of this Invitation to Bid and all appendices and the contents of any Addendum released hereto. I further certify that by virtue of executing and returning this Bidder Acknowledgement Form, I am submitting the following information as this company's response.</p>	
Name of Representative Submitting Bid:	John Thomas Almon II 
Title of Company Representative:	President
Date:	05/21/2015

**15C-32B – Bid Summary**

<p><b>Item 1</b></p>	<p><b>Playground Equipment And Outdoor Fitness Equipment</b>  <u>Firm Percentage Discount</u></p> <ul style="list-style-type: none"> <li>• Will be deducted from the catalog list prices</li> <li>• Bidders must bid a single fixed percentage discount, ex. 12% is acceptable; 11.075% is not</li> <li>• The District will accept a discount of 0%.</li> </ul> <p><u>Freight Charges:</u></p> <ul style="list-style-type: none"> <li>• All freight charges are to be prepaid by successful bidders and added to the invoice</li> <li>• The School District will only pay actual freight charges</li> <li>• It is further agreed by all vendors signing this bid proposal that title to all items ordered, remain with the vendor until received and accepted by the School District</li> <li>• Vendor is required to file all claims for damages/shortages etc.</li> </ul>	
<p><b>List the Playground Equipment Manufacturer(s) and the Outdoor Fitness Equipment Manufacturer(s) you represent</b></p>	<p><b>Fixed % Percentage Discount off List Price</b></p>	
<p>Playground Manufacture-Landscape Structures</p>	<p>3%</p>	
<p>Outdoor Fitness Equipment Manufacture-Landscape Structures</p>	<p>3%</p>	
<p></p>	<p></p>	
<p></p>	<p></p>	
<p></p>	<p></p>	
<p><b>Item 2.</b></p>	<p><b>Installation of Playground and Outdoor Fitness Equipment</b>  No Bid</p>	<p><b>Fixed Percentage</b></p>
	<p>Cost will be based on a firm fixed percentage of the equipment cost (the total after discount has been taken but before freight has been added)</p>	
<p><b>NOTE:</b>                  If bidding to only supply Playground and/or Outdoor Fitness Equipment,                  • you must list your certified installer below  <b>AND</b>                  • Your certified installer must submit a bid for installation  <b>AND</b>                  • Your certified installer must be awarded a contract for installation                  in order for you to be awarded to provide playground and/or outdoor fitness equipment</p>		
<p><b>Playground and Outdoor Fitness Equipment Installer's Company Name (if other than self):</b></p>	<p>Regal Contractors, Inc. D.W. Recreation Services, Inc.</p>	

<b>Item 3.</b>	<b>Poured In Place (PIP) Surfacing for Playgrounds and Outdoor Fitness Equipment</b>						
	<ul style="list-style-type: none"> <li>• Poured In Place (PIP) surfacing must be IPEMA Certified &amp; ADA compliant</li> <li>• Price must be stated per square foot and price must include all materials, adhesives or sub-bases</li> </ul>						
<b>List Manufacturer:</b>	Vitriturf						
Critical Fall Height	3'	4'	5'	6'	7'	8'	10'
<b>3a)</b>							
Size	<b>Cost Per Sq Ft</b>	<b>Cost Per Sq Ft</b>	<b>Cost Per Sq Ft</b>	<b>Cost Per Sq Ft</b>	<b>Cost Per Sq Ft</b>	<b>Cost Per Sq Ft</b>	<b>Cost Per Sq Ft</b>
Up to 1,000 Sq Ft	\$12.50	\$12.50	\$12.50	\$15.00	\$15.00	\$16.00	\$19.00
1,000 to 3,000 Sq Ft	\$12.00	\$12.00	\$12.00	\$12.00	\$13.00	\$14.00	\$15.00
Over 3,000 Sq Ft	\$11.00	\$11.00	\$11.00	\$11.00	\$12.00	\$13.00	\$14.00
<b>3b) Installation of PIP surfacing charge if it is not included in the prices above</b>						\$ _____ per Sq Ft	

<b>Item 4.</b>	<b>Artificial Turf installed on a playground (with fall protection)</b>						
	<ul style="list-style-type: none"> <li>• Must be IPEMA certified and ADA compliant</li> <li>• Price stated must be per square foot and price must include all materials, adhesives, etc.</li> </ul>						
<b>List Manufacturer:</b>	ForeverLawn Extreme Playground Grass						
Critical Fall Height	3'	4'	5'	6'	7'	8'	10'
<b>4a) Cost Per Sq Ft</b>							
Size	<b>Cost Per Sq Ft</b>	<b>Cost Per Sq Ft</b>	<b>Cost Per Sq Ft</b>	<b>Cost Per Sq Ft</b>	<b>Cost Per Sq Ft</b>	<b>Cost Per Sq Ft</b>	<b>Cost Per Sq Ft</b>
Up to 1,000 Sq Ft	\$13.00	\$13.00	\$13.00	\$14.00	\$14.00	\$14.00	\$15.00
1,000 to 3,000 Sq Ft	\$12.00	\$12.00	\$12.00	\$13.00	\$13.00	\$13.00	\$14.00
Over 3,000 Sq Ft	\$12.00	\$12.00	\$12.00	\$13.00	\$13.00	\$13.00	\$14.00
<b>4b) Installation of Artificial Turf charge if it is not included in the prices above</b>						\$ _____ per Sq Ft	

ATTACHMENT B

<b>Item 5.</b>	<b>Artificial Turf – Provide and install where fall protection is NOT required</b>						
<b>List Manufacturer:</b>	ForeverLawn Extreme Playground Grass						
<b>5a)</b>	Cost Per Sq Ft	Cost Per Sq Ft	Cost Per Sq Ft	Cost Per Sq Ft	Cost Per Sq Ft	Cost Per Sq Ft	Cost Per Sq Ft
Size							
Up to 1,000 Sq Ft	\$11.00						
1,000 to 3,000 Sq Ft	\$10.00						
Over 3,000 Sq Ft	\$10.00						
<b>5b)</b>	<b>Installation of Artificial Turf <u>Without</u> fall protection fee if installation is not included in the prices above</b>						\$ _____ per Sq Ft

<b>Item 6.</b>	<b>Engineered Wood Fiber</b> Must comply with ASTM and be IPEMA certified Quotes will be requested when needed <b>Indicate if you can provide (Yes or No)</b>	<input checked="" type="checkbox"/> Yes or <input type="checkbox"/> No
<b>List the Manufacturer:</b>		Irvine Wood Recovery

<b>Item 3.</b>	<b>Poured In Place (PIP) Surfacing for Playgrounds and Outdoor Fitness Equipment</b>						
	<ul style="list-style-type: none"> <li>• Poured In Place (PIP) surfacing must be IPEMA Certified &amp; ADA compliant</li> <li>• Price must be stated per square foot and price must include all materials, adhesives or sub-bases</li> </ul>						
<b>List Manufacturer:</b>	No Fault Sport Group LLC						
Critical Fall Height	3'	4'	5'	6'	7'	8'	10'
<b>3a)</b>							
Size	<b>Cost Per Sq Ft</b>	<b>Cost Per Sq Ft</b>	<b>Cos Per Sq Ft</b>	<b>Cost Per Sq Ft</b>	<b>Cost Per Sq Ft</b>	<b>Cost Per Sq Ft</b>	<b>Cost Per Sq Ft</b>
Up to 1,000 Sq Ft	\$11.00	\$11.00	\$12.00	\$12.00	\$14.00	\$16.00	\$19.00
1,000 to 3,000 Sq Ft	\$11.00	\$11.00	\$11.00	\$12.00	\$13.00	\$13.00	\$16.00
Over 3,000 Sq Ft	\$10.00	\$10.00	\$11.00	\$11.00	\$12.00	\$13.00	\$16.00
<b>3b) Installation of PIP surfacing charge if it is not included in the prices above</b>						\$ _____ per Sq Ft	

<b>Item 4.</b>	<b>Artificial Turf installed on a playground (with fall protection)</b>						
	<ul style="list-style-type: none"> <li>• Must be IPEMA certified and ADA compliant</li> <li>• Price stated must be per square foot and price must include all materials, adhesives, etc.</li> </ul>						
<b>List Manufacturer:</b>							
Critical Fall Height	3'	4'	5'	6'	7'	8'	10'
<b>4a) Cost Per Sq Ft</b>							
Size	<b>Cost Per Sq Ft</b>	<b>Cost Per Sq Ft</b>	<b>Cost Per Sq Ft</b>	<b>Cost Per Sq Ft</b>	<b>Cost Per Sq Ft</b>	<b>Cost Per Sq Ft</b>	<b>Cost Per Sq Ft</b>
Up to 1,000 Sq Ft							
1,000 to 3,000 Sq Ft							
Over 3,000 Sq Ft							
<b>4b) Installation of Artificial Turf charge if it is not included in the prices above</b>						\$ _____ per Sq Ft	



## Playground Grass Extreme Specifications

Please Select A Product

Extreme is the product that started it all. Made up of two types of blades, it incorporates high durability and realism into one quality product. A combination of straight and curled blades help fill the product and reduce infill flyout. Installed as part of our safety system, Playground Grass Extreme is the perfect finish to a great playground.

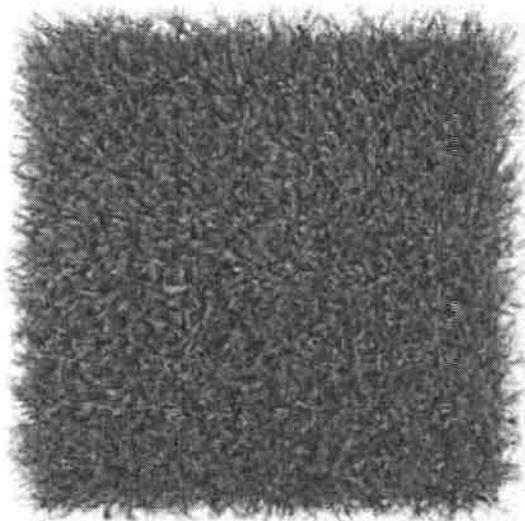

Components	Specifications
Yarn Type	Dual primaries: Polyethylene slit film XP straight/curled
Yarn Color	Field/lime green
Yarn Count	Slit film: 8,040/1
Tufting Construction	Dual primaries, same row
Blade Height	1-1/2"
Tufting Gauge	3/8"
Face Weight	45 ounces
Total Product Weight	110 ounces
Backing	3-layer backing with geotex laminate
Antimicrobial Protection	No
Seaming	Micromechanical bonding
Infill	0.75 pounds of rubber

Considering ForeverLawn for a commercial project? Our premium synthetic grass products are an excellent option, and [financing is available](#).

<b><u>Site Preparation:</u></b>		
<ul style="list-style-type: none"> <li>All bidders for installation must complete this section in order to be awarded as the pool of pre-qualified vendors for all projects under this bid</li> <li>Provide firm prices for the following line items</li> <li>Prices must be submitted in the same unit of measure as listed below:</li> </ul>		
<b>Item 7.</b>	Dig-out/ Excavation Price must include removal and disposal	\$ <u>No Bid</u> per sq. ft.
<b>Item 8.</b>	Sand, clean & suitable for playgrounds Price must include delivery and placement	\$ <u>No Bid</u> per cubic yard
<b>Item 9.</b>	Clean Fill Delivered and graded	\$ <u>No Bid</u> per sq. ft.
<b>Item 10.</b>	Concrete – provide and install All concrete shall comply with DMS & FI. Building Code Includes concrete for sidewalks There shall be no additional fee for getting the concrete to the site	
<b>10a.</b>	4" Wide X 12" Deep for PIP surfacing	\$ <u>No Bid</u> per sq. ft.
<b>10b.</b>	6" Wide X 12" Deep for artificial turf	\$ <u>No Bid</u> per sq. ft.
<b>Item 11.</b>	Recycled playcurb borders Provide and install	\$ <u>No Bid</u> per linear ft.
<b>Item 12.</b>	Aluminum ADA handrails Provide and install	\$ <u>No Bid</u> per linear ft.
<b>Item 13.</b>	Provide Utility Locates	\$ <u>No Bid</u> each
<b>Item 14.</b>	Provide signed sealed engineered drawings	\$ <u>\$1,000.00</u> per job

**Additional Site Preparation Items:**

Vendors may be required to provide quotations for optional items such as, but not limited to:

- removal and/or relocation of existing playground equipment
- replacement parts for playground components
- tree trimming or removal
- excavation/demucking for sites where rock or muck is found
- provide and lay sod in area surrounding playground where sand was (sod replacement for site restoration shall be done at no charge to the District)

Item 15	<p><b>Repair, Recap and/or Replace Playground Surfacing</b>          Bidder wishes to be in the pool of pre-qualified vendors and be eligible to respond to Request For Quotes (RFQ) for projects to Repair, Recap and/or Replace Playground Surfacing</p> <p style="text-align: right;">Mark an "X" in the space provided</p>	<p style="text-align: center;"><u>X</u> YES</p>
---------	--	---

Item 16	<p><b>Fabric Shade Structures :</b>          This will establish a pool of pre-qualified vendors to furnish and install fabric shade structures as requested in accordance with the terms, specifications, District Master Specs and conditions set forth in this bid</p> <p><i>To be in the pool of pre-qualified vendors and be eligible to respond to Request For Quotes (RFQ) for Fabric Shade Structures, you must mark an "X" in the box by "YES"</i></p>
---------	---

NOTE:

If bidding to only supply Shade Structures

- you must list your certified installer below
- AND**
- Your certified installer must submit a bid for installation
- AND**
- Your certified installer must be awarded a contract to install this item in order for you to be awarded for this item

Item 16	<b>Provide Shade Structures</b>	<u>X</u> YES	___ NO
<b>Manufacturer:</b>		USA Shade/Landscape Structures	
<b>Installer if other than self:</b>		Regal Contractors, Inc/D.W. Recreation Services, Inc.	
Item 17.  <b>Install Shade Structure</b>	___ YES	<u>X</u> NO	

**Item 18. Provide Fitness Trails (equipment/stations & surfacing)**

This will establish a pool of pre-qualified vendors to furnish and install Fitness Trails as requested in accordance with the terms, specifications and conditions set forth in this bid and all applicable codes and standards.

*To be in the pool of pre-qualified vendors and be eligible to respond to Request For Quotes (RFQ) for Fitness Trails, you must mark an "X" in the box by "YES"*

**NOTE:**

If bidding to only supply Fitness Trail Equipment/Stations,

- you must list your certified installer below

**AND**

- Your certified installer must submit a bid for installation

**AND**

- Your certified installer must be awarded a contract for the installation in order for you to be awarded to provide Fitness Trail Equipment/Stations

<b>Item 18</b>	<b>Provide Fitness Trail Equipment</b>	<input checked="" type="checkbox"/> YES	<input type="checkbox"/> NO
<b>Manufacturer:</b>	Landscape Structures		
<b>Installer if other than self:</b>	Regal Contractors, Inc./D.W. Recreation Services, Inc.		
<b>Item 19.</b>	<b><u>Install Fitness Trails and Surfacing</u></b>	<input type="checkbox"/> YES	<input checked="" type="checkbox"/> NO

<p><b>Item 20. Replacement Parts for Playground or outdoor fitness equipment and supplies such as sealer for poured in place surfacing:</b>                  List the Playground Equipment Manufacturer(s) and the Outdoor Fitness Equipment Manufacturer(s) you are authorized to sell replacement parts or supplies for and provide a firm percentage discount to be taken off list price or mark "Yes" to provide quotes if you cannot give a single fixed discount off list price (Refer to Bid Specifications)</p>	<p><b>Fixed Percentage Discount off List Price</b></p>	<p><b>Cannot give firm discount but will provide quotes when requested (Mark "Yes")</b></p>
<p>Playground Equipment-Landscape Structures</p>		<p>Yes</p>
<p>Outdoor Fitness Equipment-Landscape Structures</p>		<p>Yes</p>
<p>Delivery Business Days After Receipt of Order (ARO):</p>	<p><u>2</u> business days</p>	
<p>Address of facility where parts will be shipped from:                  601 7th Street South                  Delano, Minnesota 55328</p>		

<p><b>Item 21</b></p>	<p><b><u>Recoat existing PVC playground equipment decks</u></b>                  Provide on-site service to restore/renew decks that are worn and/or have coating that is peeling                  Includes cleaning, priming and recoating in compliance with all applicable standards an codes                  Bidder wishes to be in the pool of pre-qualified vendors and be eligible to respond to Request For Quotes (RFQ) for single jobs or larger projects to  <b>Mark an "X" in the space provided</b></p>	<p>___ YES</p>
-----------------------	---	----------------

<p><b>Vendor Name:</b></p>	
----------------------------	--

**This form must be downloaded, completed and uploaded to DemandStar with your bid response**

SCHOOL DISTRICT OF PALM BEACH COUNTY  
PURCHASING DEPARTMENT

DEBARMENT CERTIFICATION

CERTIFICATION REGARDING DEBARMENT, SUSPENSION,  
INELIGIBILITY AND VOLUNTARY EXCLUSION  
LOWER TIER COVERED TRANSACTIONS

This certification is required by the regulations implementing Executive Order 12549, Debarment and Suspension, 7 CFR Part 3017, Section 3017.510, Participants' responsibilities. The regulations were published as Part IV of the January 30, 1989, Federal Register (pages 4722-4733). Copies of the regulations may be obtained by contacting the Department of Agriculture agency with which this transaction originated. (Before Completing Certification, Read Instructions on Following Page)

- (1) The prospective lower tier participant certifies, by submission of this proposal, that neither it nor its principals is presently debarred, suspended, proposed for debarment, declared ineligible, or voluntarily excluded from participation in this transaction by an Federal department or agency.
- (2) Where the prospective lower tier participant is unable to certify to any of the statements in this certification, such prospective participants shall attach an explanation to this proposal.

Organization Name: Rep Services, Inc.

Solicitation Number or Project Name: Bid 15C-32B

Name of Authorized Representative: John Thomas Almon II

Title of Representative: President

Date: 05/21/2015

**INSTRUCTION CERTIFICATIONS**

1. By electronic submission of this form the prospective lower tier participant is providing the certification set out on the reverse side in accordance with these instructions.
2. The certification in this clause is a material representation of fact upon reliance was placed when this transaction was entered into. If it is later determined that the prospective lower tier participant knowingly rendered an erroneous certification, in addition to other remedies available to the Federal Government, the department or agency with which this transaction originated may pursue available remedies, including suspension and/or debarment.
3. The prospective lower tier participant shall provide immediate written notice to the person to which this proposal is submitted if at any time the prospective lower tier participant learns that its certification was erroneous when submitted or has become erroneous by reason of changed circumstances.
4. The terms "covered transaction," "debarred," "suspended," "ineligible," "lower tier covered transaction," "participant," "person," "primary covered transaction," "principal," "proposal," "voluntarily excluded," as used in this clause, have the meanings set out in the Definitions and Coverage section so rules implementing Executive Order 12549. You may contact the person to which this proposal is submitted for assistance in obtaining a copy of those regulations.
5. The prospective lower tier participant agrees by submitting this form that, should the proposed covered transaction be entered into, it shall not knowingly enter into any lower tier covered transaction with a person who is debarred, suspended, declared ineligible, or voluntarily excluded from participation in this covered transaction, unless authorized by the department or agency with which this transaction originated.
6. The prospective lower tier participant further agrees by submitting this form that it will include this clause titled, "Certification Regarding Debarment, Suspension, Ineligibility and Voluntary Exclusion - Lower Tier Covered Transactions," without modification, in all lower tier covered transactions and in all solicitations for lower tier covered transactions.
7. A participant in a covered transaction may rely upon a certification of a prospective participant in a lower tier covered transaction that it is not debarred, suspended, ineligible, or voluntarily excluded from the covered transaction, unless it knows that the certification is erroneous. A participant may decide the method and frequency by which is determines the eligibility of its principals. Each participant may, but is not required to, check the Non-procurement List.
8. Nothing contained in the foregoing shall be construed to require establishment of a system of records in order to render in good faith the certification required by this clause. The knowledge and information of a participant is not required to exceed that which is normally possessed by a prudent person in the ordinary course of business dealings.
9. Except for transactions authorized under paragraph 5 of these instructions, if a participant in covered transaction knowingly enters into a lower tier covered transaction with a person who is suspended, debarred, ineligible, or voluntarily excluded from participation in this transaction, in addition to other remedies available to the Federal Government, the department or agency with which this transaction originated may pursue available remedies, including suspension and/or debarment.

**PROPOSER'S STATEMENT OF PRINCIPAL PLACE OF BUSINESS**  
*(Must be completed & submitted with each competitive solicitation)*

Name of Proposer: Rep Services, Inc

Identify the state in which the Proposer has its principal place of business: Florida

Proceed as follow: **IF** your principal place of business above is located within the State of Florida, the Proposer may sign below and attach to your solicitation. No further action is required. **IF** your principal place of business is outside of the State of Florida the following must be completed by an attorney and returned with your solicitation. Failure to comply shall be considered to be non-responsive to this solicitation.

**OPINION OF OUT-OF-STATE BIDDER'S ATTORNEY ON BIDDING PREFERENCES**  
*(To be completed by the Attorney for an Out-of-State Proposer)*

**NOTICE:** Section 287.084(2), Fla. Stat., provides that "a vendor whose principal place of business is outside this state must accompany any written bid, proposal, or reply documents with a written opinion of an attorney at law licensed to practice law in that foreign state, as to the preferences, if any or none, granted by the law of that state [or political subdivision thereof] to its own business entities whose principal places of business are in that foreign state in the letting of any or all public contracts." See also: Section 287.084(1), Fla. Stat.

**LEGAL OPINION ABOUT STATE BIDDING PREFERENCES**  
*(Please Select One)*

\_\_\_\_\_ The Proposer's principal place of business is in the State of \_\_\_\_\_ and it is my legal opinion that the laws of that state **do not grant a preference** in the letting of any or all public contracts to business entities whose principal places of business are in that state.

\_\_\_\_\_ The Proposer's principal place of business is in the State of \_\_\_\_\_ and it is my legal opinion that the laws of that state **grant the following preference(s)** in the letting of any or all public contracts to business entities whose principal places of business are in that state: [Please describe applicable preference(s) and identify applicable state law(s)]:

\_\_\_\_\_  
\_\_\_\_\_  
\_\_\_\_\_

**LEGAL OPINION ABOUT POLITICAL SUBDIVISION BIDDING PREFERENCES**  
*(Please Select One)*

\_\_\_\_\_ The Proposer's principal place of business is in the political subdivision of \_\_\_\_\_ and it is my legal opinion that the laws of that political subdivision **do not grant a preference** in the letting of any or all public contracts to business entities whose principal places of business are in that political subdivision.

\_\_\_\_\_ The Proposer's principal place of business is in the political subdivision of \_\_\_\_\_ and the laws of that political subdivision **grant the following preference(s)** in the letting of any or all public contracts to business entities whose principal places of business are in that political subdivision: [Please describe applicable preference(s) and identify applicable authority granting the preference(s)]:

\_\_\_\_\_  
\_\_\_\_\_  
\_\_\_\_\_

Signature of out-of-state Proposer's attorney: \_\_\_\_\_

Printed name of out-of-state Proposer's attorney: \_\_\_\_\_

Address of out-of-state bidder's attorney: \_\_\_\_\_

\_\_\_\_\_

Telephone Number of out-of-state bidder's attorney: (\_\_\_\_) \_\_\_\_ - \_\_\_\_\_

Email address of out-of-state bidder's attorney: \_\_\_\_\_

Attorney's states of bar admission: \_\_\_\_\_

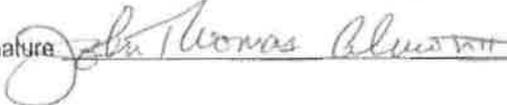
Proposer's Printed Name: John Thomas Almon II Signature 

Company Name: Rep Services, Inc



THE SCHOOL DISTRICT OF PALM BEACH COUNTY  
**Drug-Free Workplace Certification**

Preference must be given to vendors submitting a certification with their bid/proposal certifying they have a drug-free workplace in accordance with Section 287.087, Florida Statutes. This requirement affects all public entities of the State and becomes effective January 1, 1991. The special condition is as follows:

**IDENTICAL TIE BIDS** - Preference shall be given to businesses with drug-free workplace programs. Whenever two or more bids which are equal with respect to price, quality, and service are received by the State or by any political subdivision for the procurement of commodities or contractual services, a bid received from a business that certifies that it has implemented a drug-free workplace program shall be given preference in the award process. Established procedures for processing tie bids will be followed if none of the tied vendors have a drug-free workplace program, a business shall:

- 1) Publish a statement notifying employees that the unlawful manufacture, distribution, dispensing, possession, or use of a controlled substance is prohibited in the workplace and specifying the actions that will be taken against employees for violations of such prohibition.
- 2) Inform employees about the dangers of drug abuse in the workplace, the business's policy of maintaining a drug-free workplace, any available drug counseling, rehabilitation, and employee assistance programs, and the penalties that may be imposed upon employees for drug abuse violations.
- 3) Give each employee engaged in providing the commodities or contractual services that are under bid a copy of the statement specified in subsection (1).
- 4) In the statement specified in subsection (1), notify the employees that, as a condition of working on the commodities or contractual services that are under bid, the employee will abide by the terms of the statement and will notify the employer of any conviction of, or plea of guilty or nolo contendere to, any violation of chapter 893 or of any controlled substance law of the United States or any state, for a violation occurring in the workplace no later than five (5) days after such conviction.
- 5) Impose a sanction on, or require the satisfactory participation in a drug abuse assistance or rehabilitation program if such is available in the employee's community, by any employee who is so convicted.
- 6) Make a good faith effort to continue to maintain a drug-free workplace through implementation of this section.

As the person authorized to sign the statement, I certify that this firm complies fully with the above requirements.

  
VENDOR'S SIGNATURE  
 Rep Services, Inc  
COMPANYNAME

05/21/2015  
DATE

**Must be executed and returned with attached bid at time of bid opening to be considered.**



THE SCHOOL DISTRICT OF PALM BEACH COUNTY  
**Beneficial Interest and Disclosure of Ownership Affidavit**

Bid No. 10C-54B Project No./ Title Playground Equipment, Surfacing, Shade Structures & Fitness Trails

Corporate Name Rep Services, Inc. Tax FEIN No. 592978507

Before me, the undersigned authority, personally appeared, John T. Almon II, ("Corporate Representative") this 17 day of February, 2015, who, first being duly sworn, as required by law, subject to the penalties prescribed for perjury, deposes and says:

- 1) Corporate Representative has read the contents of this Affidavit, has actual knowledge of the facts contained herein, and states that the facts contained herein are true, correct, and complete.
- 2) The following is a list of every "person" (as defined in Section 1.01(3), Florida Statutes to include individuals, children firms, associates, joint adventures, partnerships, estates, trusts, business trusts, syndicates, fiduciaries, corporations and all other groups and combinations) holding 5% or more of the beneficial interest in the disclosing entity: (If more space is needed, attach separate sheet)

A. Persons or corporate entities owning 5% or more:

Name	Address	Percentage
LeDonna H. Almon	305 Allison Ave. Longwood, FL 32750	49
John T. Almon II	305 Allison Ave. Longwood, FL 32750	49

B. Persons or corporate entities who hold by proxy the voting power of 5% or more:

Name	Address	Percentage

C. Stock held for others and for whom held:

1. Name / 2. From Whom Held	Address	Percentage
1. <u> </u>		
2. <u> </u>		
1. <u> </u>		
2. <u> </u>		
1. <u> </u>		
2. <u> </u>		

CORPORATE REPRESENTATIVE

By: John T. Almon II

SWORN TO and subscribed before me this 17 day of February, 2015, by John T. Almon II Such person(s) (Notary Public must check applicable box).

is/are personally known to me.  produced a current driver license(s).  produced \_\_\_\_\_ as identification.

(NOTARY PUBLIC SEAL)

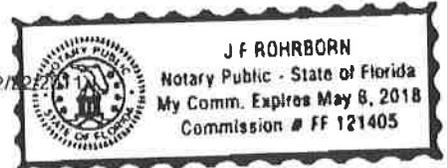

J F ROHRBORN  
 Notary Public  
 (Print, Type or Stamp Name of Notary Public)

**Bid 15C-32B****AREA REPRESENTATIVE**

Please list the contact for this bid

Vendor Name:	Rep Services, Inc.
Area Representative:	Kevin Furman
Email Address:	kfurman@repservices.com
Cell Phone Number:	321-277-4483
Office Number (With extension)	561-333-4451

**This form must be downloaded, completed and uploaded to DemandStar with your bid response**

SCHOOL DISTRICT OF PALM BEACH COUNTY  
PURCHASING DEPARTMENT

EARLY PAYMENT TERMS

<p><b>BID NAME/NUMBER:</b> _____</p> <p><b>VENDOR NAME:</b> _____</p>
---

If vendor chooses not to participate in Early Payment Terms, please acknowledge by placing N/A here → N/A.

<p><b>EARLY PAYMENT:</b> Specify terms and discount for early payment. Check which terms you will be willing to provide for the duration of this contract to the School District.</p>
<p><input type="radio"/> 0.5% 10 net 30 *</p>
<p><input type="radio"/> 0.75% 5 net 30 *</p>

\* Upon receipt of invoice by the School District of Palm Beach County Accounts Payable Department.

**Note:** Updating to these terms will affect all of your District payments. If you choose to revise these terms at a later date, the terms will affect all of your payments from the District.

**SCHOOL DISTRICT OF PALM BEACH COUNTY  
PURCHASING DEPARTMENT**

**Bid 15C-32B- REFERENCES**

**Vendor Name: Rep Services, Inc.**

**This information will be used in the evaluation of this bid.**

- Complete the information below
- Notify each reference that we will be contacting them by email and their response will be used in evaluating your company
- School District or Governmental agencies are preferred references
- References shall not be for work performed more than 3 years ago
- You may not list the School District of Palm Beach County as more than one reference

State the type of work you did for each reference from this list of options (list all that apply):

**Provided playground equipment**  
**Installed playground or outdoor fitness equipment**  
**Provided & installed PIP surfacing**  
**Provided & installed artificial turf**  
**Provided fabric shade structure**  
**Installed fabric shade structure**  
**Provided fitness trails**  
**Installed fitness trails**

**Reference 1**

<b>School District, Governmental Agency or Company:</b>	Village of Royal Palm Beach
<b>Contact Person:</b>	Lou Recchio
<b>Email:</b>	lrecchio@royalpalmbeach.com
<b>Phone #:</b>	561-790-5124
<b>Type of work (choose from list above)</b>	Provide fabric shade structure Installed fabric shade structure
<b>Date work was completed</b>	01/30/2015

## Reference 2

School District, Governmental Agency or Company:	Lee Memorial Health System
Contact Person:	John Croce
Email:	john.croce@leememorial.org
Phone #:	239-343-2000
Type of work (choose from list above)	Provided fitness trail Installed fitness trail
Date work was completed	05/07/2015

## Reference 3

School District, Governmental Agency or Company:	City of Pahokee
Contact Person:	Erica Redmon
Email:	eredmon@cityofpahokee.com
Phone #:	561-924-5534
Type of work (choose from list above)	Provided playground equipment Installed playground equipment
Date work was completed	07/21/2014

## Reference 4

School District, Governmental Agency or Company:	Indian Trail Improvement District
Contact Person:	Tim Wojnar
Email:	twojnar@indiantrail.com
Phone #:	561-721-4836
Type of work (choose from list above)	Provided playground equipment Installed playground equipment Provided & installed artificial turf
Date work was completed	02/28/2014

**Reference 5**

<b>School District, Governmental Agency or Company:</b>	City of Boca Raton
<b>Contact Person:</b>	Drew Leganik
<b>Email:</b>	DLeganik@ci.boca-raton.fl.us
<b>Phone #:</b>	561-393-7840
<b>Type of work (choose from list above)</b>	Provided playground equipment Installed playground equipment Provided & installed PIP surfacing
<b>Date work was completed</b>	07/02/2014

**This form must be downloaded, completed and uploaded to DemandStar with your bid response**

School District of Palm Beach County  
MINORITY CERTIFICATION INFORMATION

Bid 15C-32B

\* Check here if N/A:  X

Form **must be submitted** with your bid response to **Demandstar.com**

Minority Certification applications are available through the Minority Business Enterprise located at:

Office of Diversity in Business Practices  
School District of Palm Beach County  
3300 Forest Hill Boulevard, Suite A-106  
West Palm Beach, FL 33406-5871  
Phone: (561) 434-8508  
<http://www.palmbeachschools.org/mwbe/>

---

**Are you a minority vendor certified by:** (Check if appropriate)

Palm Beach County School District \_\_\_\_\_

State of Florida \_\_\_\_\_

If yes, expiration date \_\_\_\_\_

Minority Classification \_\_\_\_\_

---

If you are not a certified minority vendor and intend to sub-contract with a certified minority firm(s), please list the vendors and the estimated dollar value below:

<u>Vendor</u>	<u>Estimated Dollar Value</u>
_____	\$ _____
_____	\$ _____
_____	\$ _____

Reminder: *Download all documents, complete them and **save as a single PDF document** and re-upload them to DemandStar.*



THE SCHOOL DISTRICT  
OF PALM BEACH COUNTY, FLORIDA

SHARON SWAN  
DIRECTOR

ATTACHMENT C  
MICHAEL J. BURKE  
CHIEF OPERATING OFFICER

Purchasing Department  
3300 Forest Hill Boulevard, Suite A-323  
West Palm Beach, FL 33406-5813  
Phone: (561) 434-8214 Fax: (561) 963-3823  
[www.palmbeachschools.org/purchasing](http://www.palmbeachschools.org/purchasing)

August 25, 2015

Rep Services, Inc.  
Mr. John Thomas Almon II, President  
581 Technology Park, Suite 1009  
Lake Mary, FL 32746  
[kfuman@repservices.com](mailto:kfuman@repservices.com)

Subject: Letter of Agreement  
Bid Number: 15C-32B  
Title: Term Contract for Playground Equipment, Outdoor Fitness Equipment, Surfacing,  
Fitness Trails and Fabric Shade Structures  
Contract Term: August 20, 2015 through August 19, 2020

Dear Mr. Almon:

This is to advise you that the School District of Palm Beach County, Florida, has accepted your offer to furnish playground equipment, outdoor equipment, surfacing, fitness trails and fabric shade structures. This acceptance is subject to compliance with bid specifications, terms and conditions, all pertinent laws of the State of Florida and instructions as determined by the General Counsel for the School District.

A Certificate of Insurance as per special condition "S", "Insurance Requirements" must be emailed to [insurancecertificate@palmbeachschools.org](mailto:insurancecertificate@palmbeachschools.org), or faxed to 561-963-3823 within seven (7) days of this notification. Your insurance company is required to have the **School Board of Palm Beach County, Florida, NAMED AS AN ADDITIONAL INSURED**. No work shall commence until we receive the Certificate of Insurance and it must reference the above Bid Number. Please be sure to advise your insurance carrier.

Purchase orders may be issued to cover the playground equipment, outdoor equipment, surfacing, fitness trails and fabric shade structures as the need arises and will be your notification to proceed with fulfilling the School Districts request. Shipment without proper authorization may result in nonpayment.

If you have any questions, please do not hesitate to call my office at 561-434-8310. Thank you for your bid and we are looking forward to doing business with you and your company.

Sincerely,

Sharon Swan, C.P.M., Director  
Purchasing Department

CC: bid file  
Karen Adducci, Purchasing Agent

---

The School District of Palm Beach County, Florida  
A Top-Rated District by the Florida Department of Education Since 2005  
*An Equal Education Opportunity Provider and Employer*

## AGREEMENT

**THIS AGREEMENT** is made and entered into as of this \_\_\_\_ day of \_\_\_\_\_, 2016, by and between

**THE SCHOOL BOARD OF BROWARD COUNTY, FLORIDA**

(hereinafter referred to as “SBBC”),  
a body corporate and political subdivision of the State of Florida,  
whose principal place of business is  
600 Southeast Third Avenue, Fort Lauderdale, Florida 33301

and

**SUPERIOR PARK SYSTEMS, INC.**

(hereinafter referred to as “VENDOR”),  
whose principal place of business is  
1418 Scott Street  
Hollywood, FL 33020

**WHEREAS**, SBBC desires to obtain goods and services of VENDOR to provide playground equipment, outdoor equipment, surfacing, fitness trails and fabric shade structures; and

**WHEREAS**, SBBC desires to utilize an existing contract between The School District of Palm Beach County, Florida (the “SDPBC”) dated August 19, 2015 and awarded pursuant to ITB 15C-32B Playground Equipment, Outdoor Fitness Equipment, Surfacing, Fitness Trails and Fabric Shade Structures as amended per addendum No.: 1, dated May 20, 2015 as permitted by Rule 6A.1.012(6), Florida Administrative Code and School Board Policy; and

**WHEREAS**, VENDOR and SBBC desire to enter into this Agreement for the use of the ITB for Playground Equipment, Outdoor Fitness Equipment, Surfacing, Fitness Trails and Fabric Shade Structures by and between the SDPBC and VENDOR.

**NOW, THEREFORE**, in consideration of the premises and of the mutual covenants contained herein and other good and valuable consideration, the receipt and sufficiency of which is hereby acknowledged, the Parties hereby agree as follows:

### **ARTICLE 1 - RECITALS**

1.01 **Recitals.** The parties agree that the foregoing recitals are true and correct and that such recitals are incorporated herein by reference.

## ARTICLE 2 – SPECIAL CONDITIONS

2.01 **Term of Agreement.** Unless terminated earlier pursuant to Section 3.05 of this Agreement, the term of this Agreement shall **commence from date of award and conclude on July 31, 2018**. The term of the Agreement may, by mutual agreement, be extended for two additional one-year periods and, if needed, 180 days beyond the expiration date of the renewal period. SBBC's Procurement & Warehousing Services Department, will, if considering renewing, request a letter consenting to renewal from VENDOR, prior to the end of the term. Any renewal period shall be approved by an Amendment to this Agreement executed by both parties.

2.02 **Priority of Documents.** The Contract Documents of this Agreement consist of the following documents, in order of priority. In the event of a conflict between the documents, the priority of the documents shall be as follows:

- First: This Agreement,
- Second: The School District of Palm of Beach County Letter of Agreement ("Letter of Agreement"),
- Third: Addendum No. 1,
- Fourth: ITB 15C-32B Playground Equipment, Outdoor Fitness Equipment, Surfacing, Fitness Trails and Fabric Shade Structures (the "ITB"),
- Fifth: Response to the ITB 15C-32B by VENDOR (the "Response to ITB").

2.02.01 The term "The School District of Palm Beach County, Florida" shall be replaced with "The School Board of Broward County, Florida" in all instances where so noted in the attached Letter of Agreement, Addendum No. 1, the ITB and the Response, but which are *not* specifically set forth in this Agreement.

2.02.02 All references to policies of The School District of Palm Beach County, Florida shall be replaced with references to the corresponding and applicable policies of SBBC in all instances where so noted in the attached Letter of Agreement, Addendum No. 1, the ITB and the Response, but which are *not* specifically set forth in the Agreement. **NOTE: It is the responsibility of the VENDOR to request and obtain copies of all such policies of the SBBC.**

2.03 **Services.** Vendor shall provide SBBC goods and services, in accordance with the terms, conditions, and specifications of ITB 15C-32B awarded to VENDOR by the SDPBC. **Attachment C**, Letter of Agreement and **Attachment A**, ITB 15C-32B. Goods and services may include the purchase and/or installation of playground equipment at various SBBC school locations.

VENDOR shall not proceed with any work until such time as it receives a fully executed Purchase Order from the SBBC, which shall specifically identify the quantity of materials and/or work to be provided and/or performed, the location for material delivery or work, the time for provision of such materials and/or work, and the total cost of such materials and/or work.

The materials and/or work identified in the Purchase Order, as well as the place of delivery or performance of such work, shall supersede and replace any such references in the attached Letter of Agreement, Addendum No. 1, the ITB and the Response.

2.04 **Pricing.** SBBC shall pay VENDOR for goods and services rendered under this Agreement in accordance with VENDOR's response to ITB 15C-32B, **Attachment B** and the terms, conditions, and specification of ITB 15C-32B awarded by the SDPBC to VENDOR, **Attachment C**, Letter of Agreement.

VENDOR may offer SBBC a special educational discount for pricing and reduce the cost of purchases during the contract term. VENDOR may invoice SBBC at a lower price than the original bid price submitted in ITB 15C-32B. SBBC may negotiate pricing with VENDOR to receive the best offer.

2.05 **Payment.** SBBC shall pay VENDOR goods for goods and services as set forth in a fully-executed Purchase Order, and in accordance with the terms, conditions, and specification of ITB 15C-32B awarded to VENDOR by the SDPBC. **Attachment C**

2.06 **Invoices:** Invoices shall be mailed to Physical Plant Operations, 3810 N. W. 10th Avenue, Fort Lauderdale, Florida 33309. However, if the Purchase Order relates to the *School Choice Enhancement Program*, invoices shall be mailed to The Office of Facilities and Construction Management, 3775 SW 16<sup>th</sup> Street, Fort Lauderdale, FL 33312. Delivery copies, packing slips and invoices to SBBC **MUST** include the following to permit SBBC to verify prices with this agreement and expedite the use of material.

- A. Purchase Order number
- B. Complete description of the items
- C. Itemized list prices
- D. Total dollar amount shall be net

2.07 **Inspection of VENDOR's Records by SBBC.** VENDOR shall establish and maintain books, records and documents (including electronic storage media) sufficient to reflect all income and expenditures of funds provided by SBBC under this Agreement. All VENDOR's Records, regardless of the form in which they are kept, shall be open to inspection and subject to audit, inspection, examination, evaluation and/or reproduction, during normal working hours, by SBBC's agent or its authorized representative to permit SBBC to evaluate, analyze and verify the satisfactory performance of the terms and conditions of this Agreement and to evaluate, analyze and verify any and all invoices, billings, payments and/or claims submitted by VENDOR or any of VENDOR's payees pursuant to this Agreement. VENDOR's Records subject to examination shall include, without limitation, those records necessary to evaluate and verify direct and indirect costs (including overhead allocations) as they may apply to costs associated with this Agreement. VENDOR's Records subject to this section shall include any and all documents pertinent to the evaluation, analysis, verification and reconciliation of any and all expenditures under this Agreement without regard to funding sources.

(a) **VENDOR's Records Defined.** For the purposes of this Agreement, the term "VENDOR's Records" shall include, without limitation, accounting records, payroll time

sheets, cancelled payroll checks, W-2 forms, written policies and procedures, computer records, disks and software, videos, photographs, executed subcontracts, subcontract files (including proposals of successful and unsuccessful bidders), original estimates, estimating worksheets, correspondence, change order files (including sufficient supporting documentation and documentation covering negotiated settlements), and any other supporting documents that would substantiate, reconcile or refute any charges and/or expenditures related to this Agreement.

(b) Duration of Right to Inspect. For the purpose of such audits, inspections, examinations, evaluations and/or reproductions, SBBC's agent or authorized representative shall have access to VENDOR's Records from the effective date of this Agreement, for the duration of the term of this Agreement, and until the later of five (5) years after the termination of this Agreement or five (5) years after the date of final payment by SBBC to VENDOR pursuant to this Agreement.

(c) Notice of Inspection. SBBC's agent or its authorized representative shall provide VENDOR reasonable advance notice (not to exceed two (2) weeks) of any intended audit, inspection, examination, evaluation and or reproduction.

(d) Audit Site Conditions. SBBC's agent or its authorized representative shall have access to VENDOR's facilities and to any and all records related to this Agreement, and shall be provided adequate and appropriate work space in order to exercise the rights permitted under this section.

(e) Failure to Permit Inspection. Failure by VENDOR to permit audit, inspection, examination, evaluation and/or reproduction as permitted under this Section shall constitute grounds for termination of this Agreement by SBBC for cause and shall be grounds for the denial of some or all of any VENDOR's claims for payment by SBBC.

(f) Overcharges and Unauthorized Charges. If an audit conducted in accordance with this Section discloses overcharges or unauthorized charges to SBBC by VENDOR in excess of two percent (2%) of the total billings under this Agreement, the actual cost of SBBC's audit shall be paid by VENDOR. If the audit discloses billings or charges to which Insert Name is not contractually entitled, VENDOR shall pay said sum to SBBC within twenty (20) days of receipt of written demand under otherwise agreed to in writing by both parties.

(g) Inspection of Subcontractor's Records. VENDOR shall require any and all subcontractors, insurance agents and material suppliers (hereafter referred to as "Payees") providing services or goods with regard to this Agreement to comply with the requirements of this section by insertion of such requirements in any written subcontract. Failure by VENDOR to include such requirements in any subcontract shall constitute grounds for termination of this Agreement by SBBC for cause and shall be grounds for the exclusion of some or all of any Payee's costs from amounts payable by SBBC to VENDOR pursuant to this Agreement and such excluded costs shall become the liability of VENDOR.

(h) Inspector General Audits. VENDOR shall comply and cooperate immediately with any inspections, reviews, investigations, or audits deemed necessary by the Florida Office of the Inspector General or by any other state or federal officials.

2.08 **Notice.** When any of the parties desire to give notice to the other, such notice must be in writing, sent by U.S. Mail, postage prepaid, addressed to the party for whom it is intended at the place last specified; the place for giving notice shall remain such until it is changed by written notice in compliance with the provisions of this paragraph. For the present, the Parties designate the following as the respective places for giving notice:

To SBBC: **Superintendent of Schools  
The School Board of Broward County, Florida  
600 Southeast Third Avenue  
Fort Lauderdale, Florida 33301**

With a Copy to: **Director, Physical Plant Operations  
The School Board of Broward County, Florida  
3810 NW 10<sup>th</sup> Avenue  
Fort Lauderdale, FL 33309**

To VENDOR: **Mitch Leitner, President  
1418 Scott Street  
Hollywood, FL 33020**

2.09 **Background Screening.** VENDOR agrees to comply with all requirements of Sections 1012.32 and 1012.465, Florida Statutes, and all of its personnel who (1) are to be permitted access to school grounds when students are present, (2) will have direct contact with students, or (3) have access or control of school funds, will successfully complete the background screening required by the referenced statutes and meet the standards established by the statutes. This background screening will be conducted by SBBC in advance of VENDOR or its personnel providing any services under the conditions described in the previous sentence. VENDOR shall bear the cost of acquiring the background screening required by Section 1012.32, Florida Statutes, and any fee imposed by the Florida Department of Law Enforcement to maintain the fingerprints provided with respect to VENDOR and its personnel. The parties agree that the failure of VENDOR to perform any of the duties described in this section shall constitute a material breach of this Agreement entitling SBBC to terminate immediately with no further responsibilities or duties to perform under this Agreement. VENDOR agrees to indemnify and hold harmless SBBC, its officers and employees from any liability in the form of physical or mental injury, death or property damage resulting from VENDOR's failure to comply with the requirements of this Section or with Sections 1012.32 and 1012.465, Florida Statutes.

### **ARTICLE 3 – GENERAL CONDITIONS**

3.01 **No Waiver of Sovereign Immunity.** Nothing herein is intended to serve as a waiver of sovereign immunity by any agency or political subdivision to which sovereign immunity may be applicable or of any rights or limits to liability existing under Section 768.28, Florida Statutes. This section shall survive the termination of all performance or obligations under this Agreement and shall be fully binding until such time as any proceeding brought on account of this Agreement is barred by any applicable statute of limitations.

3.02 **No Third Party Beneficiaries.** The parties expressly acknowledge that it is not their intent to create or confer any rights or obligations in or upon any third person or entity under this Agreement. None of the parties intend to directly or substantially benefit a third party by this Agreement. The parties agree that there are no third party beneficiaries to this Agreement and that no third party shall be entitled to assert a claim against any of the parties based upon this Agreement. Nothing herein shall be construed as consent by an agency or political subdivision of the State of Florida to be sued by third parties in any matter arising out of any contract.

3.03 **Independent Contractor.** The parties to this agreement shall at all times be acting in the capacity of independent contractors and not as an officer, employee or agent of one another. Neither party or its respective agents, employees, subcontractors or assignees shall represent to others that it has the authority to bind the other party unless specifically authorized in writing to do so. No right to SBBC retirement, leave benefits or any other benefits of SBBC employees shall exist as a result of the performance of any duties or responsibilities under this Agreement. SBBC shall not be responsible for social security, withholding taxes, contributions to unemployment compensation funds or insurance for the other party or the other party's officers, employees, agents, subcontractors or assignees.

3.04 **Equal Opportunity Provision.** The parties agree that no person shall be subjected to discrimination because of age, race, color, disability, gender identity, gender expression marital status, national origin, religion, sex or sexual orientation in the performance of the parties' respective duties, responsibilities and obligations under this Agreement.

3.05 **Termination.** This Agreement may be canceled with or without cause by SBBC during the term hereof upon thirty (30) days written notice to the other parties of its desire to terminate this Agreement. SBBC shall have no liability for any property left on SBBC's property by any party to this Agreement after the termination of this Agreement. Any party contracting with SBBC under this Agreement agrees that any of its property placed upon SBBC's facilities pursuant to this Agreement shall be removed within ten (10) business days following the termination, conclusion or cancellation of this Agreement and that any such property remaining upon SBBC's facilities after that time shall be deemed to be abandoned, title to such property shall pass to SBBC, and SBBC may use or dispose of such property as SBBC deems fit and appropriate.

3.06 **Default.** The parties agree that, in the event that either party is in default of its obligations under this Agreement, the non-defaulting party shall provide to the defaulting party (30) days written notice to cure the default. However, in the event said default cannot be cured within said thirty (30) day period and the defaulting party is diligently attempting in good faith to cure same, the time period shall be reasonably extended to allow the defaulting party additional cure time. Upon the occurrence of a default that is not cured during the applicable cure period, this Agreement may be terminated by the non-defaulting party upon thirty (30) days notice. This remedy is not intended to be exclusive of any other remedy, and each and every such remedy shall be cumulative and shall be in addition to every other remedy now or hereafter existing at law or in equity or by statute or otherwise. No single or partial exercise by any party of any right, power, or remedy hereunder shall preclude any other or future exercise thereof. Nothing in this section shall be construed to preclude termination for convenience pursuant to Section 3.05.

3.07 **Annual Appropriation.** The performance and obligations of SBBC under this Agreement shall be contingent upon an annual budgetary appropriation by its governing body. If SBBC does not allocate funds for the payment of services or products to be provided under this Agreement, this Agreement may be terminated by SBBC at the end of the period for which funds have been allocated. SBBC shall notify the other party at the earliest possible time before such termination. No penalty shall accrue to SBBC in the event this provision is exercised, and SBBC shall not be obligated or liable for any future payments due or any damages as a result of termination under this section.

3.08 **Excess Funds.** Any party receiving funds paid by SBBC under this Agreement agrees to promptly notify SBBC of any funds erroneously received from SBBC upon the discovery of such erroneous payment or overpayment. Any such excess funds shall be refunded to SBBC with interest calculated from the date of the erroneous payment or overpayment. Interest shall be calculated using the interest rate for judgments under Section 55.03, Florida Statutes, applicable at the time the erroneous payment or overpayment was made by SBBC.

3.09 **Public Records.** Pursuant to Section 119.0701, Florida Statutes, any party contracting with SBBC is required to (a) keep and maintain available for public inspection any records that pertain to services rendered under this Agreement; (b) provide the public with access to public records on the same terms and conditions that SBBC would provide such records and at a cost that does not exceed the cost provided in Chapter 119, Florida Statutes or as otherwise provided by law; (c) ensure that public records that are exempt or confidential and exempt from public records disclosure requirements are not disclosed except as authorized by law; and (d) meet all requirements for retaining public records and transfer, at no cost to SBBC, all public records in that party's possession upon termination of its Agreement with SBBC and destroy any duplicate public records that are exempt or confidential and exempt from public records disclosure requirements. All of such party's records stored electronically must be provided to SBBC in a format that is compatible with SBBC's information technology systems. Each party shall maintain its own respective records and documents associated with this Agreement in accordance with the records retention requirements applicable to public records. Each party shall be responsible for compliance with any public documents request served upon it pursuant to Section 119.07, Florida Statutes, and any resultant award of attorney's fees for non-compliance with that law. Each party acknowledges that this Agreement and all attachments thereto are public records and do not constitute trade secrets.

3.10 **Student Records:** Notwithstanding any provision to the contrary within this Agreement, any party contracting with SBBC under this Agreement shall fully comply with the requirements of Sections 1002.22 and 1002.221, Florida Statutes; FERPA, and any other state or federal law or regulation regarding the confidentiality of student information and records. Each such party agrees, for itself, its officers, employees, agents, representatives, contractors or subcontractors, to fully indemnify and hold harmless SBBC and its officers and employees for any violation of this section, including, without limitation, defending SBBC and its officers and employees against any complaint, administrative or judicial proceeding, payment of any penalty imposed upon SBBC, or payment of any and all costs, damages, judgments or losses incurred by or imposed upon SBBC arising out of a breach of this covenant by the party, or an officer, employee, agent, representative, contractor, or sub-contractor of the party to the extent that the party or an officer, employee, agent, representative, contractor, or sub-contractor of the party

shall either intentionally or negligently violate the provisions of this section or of Sections 1002.22 and/or 1002.221, Florida Statutes.

3.11 **Compliance with Laws.** Each party shall comply with all applicable federal and state laws, codes, rules and regulations in performing its duties, responsibilities and obligations pursuant to this Agreement.

3.12 **Place of Performance.** All obligations of SBBC under the terms of this Agreement are reasonably susceptible of being performed in Broward County, Florida and shall be payable and performable in Broward County, Florida.

3.13 **Governing Law and Venue.** This Agreement shall be interpreted and construed in accordance with and governed by the laws of the State of Florida. Any controversies or legal problems arising out of this Agreement and any action involving the enforcement or interpretation of any rights hereunder shall be submitted to the jurisdiction of the State courts of the Seventeenth Judicial Circuit of Broward County, Florida.

3.14 **Entirety of Agreement.** This document incorporates and includes all prior negotiations, correspondence, conversations, agreements and understandings applicable to the matters contained herein and the parties agree that there are no commitments, agreements or understandings concerning the subject matter of this Agreement that are not contained in this document. Accordingly, the parties agree that no deviation from the terms hereof shall be predicated upon any prior representations or agreements, whether oral or written.

3.15 **Binding Effect.** This Agreement shall be binding upon and inure to the benefit of the parties hereto and their respective successors and assigns.

3.16 **Assignment.** Neither this Agreement or any interest herein may be assigned, transferred or encumbered by any party without the prior written consent of the other party. There shall be no partial assignments of this Agreement including, without limitation, the partial assignment of any right to receive payments from SBBC.

3.17 **Incorporation by Reference.** Exhibits attached hereto and referenced herein shall be deemed to be incorporated into this Agreement by reference.

3.18 **Captions.** The captions, section designations, section numbers, article numbers, titles and headings appearing in this Agreement are inserted only as a matter of convenience, have no substantive meaning, and in no way define, limit, construe or describe the scope or intent of such articles or sections of this Agreement, nor in any way effect this Agreement and shall not be construed to create a conflict with the provisions of this Agreement.

3.19 **Severability.** In the event that any one or more of the sections, paragraphs, sentences, clauses or provisions contained in this Agreement is held by a court of competent jurisdiction to be invalid, illegal, unlawful, unenforceable or void in any respect, such shall not affect the remaining portions of this Agreement and the same shall remain in full force and effect as if such invalid, illegal, unlawful, unenforceable or void sections, paragraphs, sentences, clauses or provisions had never been included herein.

3.20 **Preparation of Agreement.** The parties acknowledge that they have sought and obtained whatever competent advice and counsel as was necessary for them to form a full and complete understanding of all rights and obligations herein and that the preparation of this Agreement has been their joint effort. The language agreed to herein expresses their mutual intent and the resulting document shall not, solely as a matter of judicial construction, be construed more severely against one of the parties than the other.

3.21 **Amendments.** No modification, amendment, or alteration in the terms or conditions contained herein shall be effective unless contained in a written document prepared with the same or similar formality as this Agreement and executed by each party hereto.

3.22 **Waiver.** The parties agree that each requirement, duty and obligation set forth herein is substantial and important to the formation of this Agreement and, therefore, is a material term hereof. Any party's failure to enforce any provision of this Agreement shall not be deemed a waiver of such provision or modification of this Agreement unless the waiver is in writing and signed by the party waiving such provision. A written waiver shall only be effective as to the specific instance for which it is obtained and shall not be deemed a continuing or future waiver.

3.23 **Force Majeure.** Neither party shall be obligated to perform any duty, requirement or obligation under this Agreement if such performance is prevented by fire, hurricane, earthquake, explosion, wars, sabotage, accident, flood, acts of God, strikes, or other labor disputes, riot or civil commotions, or by reason of any other matter or condition beyond the control of either party, and which cannot be overcome by reasonable diligence and without unusual expense ("Force Majeure"). In no event shall a lack of funds on the part of either party be deemed Force Majeure.

3.24 **Survival.** All representations and warranties made herein, indemnification obligations, obligations to reimburse SBBC, obligations to maintain and allow inspection and audit of records and property, obligations to maintain the confidentiality of records, reporting requirements, and obligations to return public funds shall survive the termination of this Agreement.

3.25 **Contract Administration.** SBBC has delegated authority to the Superintendent of Schools or his/her designee to take any actions necessary to implement and administer this Agreement.

3.26. **Liability.** This section shall survive the termination of all performance or obligations under this Agreement and shall be fully binding until such time as any proceeding brought on account of this Agreement is barred by any applicable statute of limitations.

A. By SBBC: SBBC agrees to be fully responsible up to the limits of Section 768.28, Florida Statutes, for its acts of negligence, or its employees' acts of negligence when acting within the scope of their employment and agrees to be liable for any damages resulting from said negligence.

B. By VENDOR: VENDOR agrees to indemnify, hold harmless and defend SBBC, its agents, servants and employees from any and all claims, judgments, costs, and expenses including, but not limited to, reasonable attorney's fees, reasonable investigative and discovery

costs, court costs and all other sums which SBBC, its agents, servants and employees may pay or become obligated to pay on account of any, all and every claim or demand, or assertion of liability, or any claim or action founded thereon, arising or alleged to have arisen out of the products, goods or services furnished by VENDOR, its agents, servants or employees; the equipment of VENDOR, its agents, servants or employees while such equipment is on premises owned or controlled by SBBC; or the negligence of VENDOR or the negligence of VENDOR's agents when acting within the scope of their employment, whether such claims, judgments, costs and expenses be for damages, damage to property including SBBC's property, and injury or death of any person whether employed by VENDOR, SBBC or otherwise.

3.27 **Travel.** Local travel shall not be billed as a reimbursable expense. Out of county travel and per diem may be allowable at the sole discretion of SBBC. SBBC has delegated authority to the Superintendent of Schools or his/her designee to provide prior approval to VENDOR for any and all travel and per diem. Should any out of county travel and/or per diem be allowed, then it shall be billed and reimbursed in compliance with the current or updated School Board Policy 3400 and/or other relevant School Board Policies.

3.28 **School Board Policies.** VENDOR agrees to comply with all School Board Policies, local, state and federal laws.

3.29 **Authority.** Each person signing this Agreement on behalf of either party individually warrants that he or she has full legal power to execute this Agreement on behalf of the party for whom he or she is signing, and to bind and obligate such party with respect to all provisions contained in this Agreement.

**IN WITNESS WHEREOF**, the Parties hereto have made and executed this Agreement on the date first above written.

**FOR SBBC**

(Corporate Seal)

THE SCHOOL BOARD OF BROWARD  
COUNTY, FLORIDA

ATTEST:

By \_\_\_\_\_  
Dr. Rosalind Osgood, Chair

\_\_\_\_\_  
Robert W. Runcie, Superintendent of Schools

Approved as to Form and Legal Content:

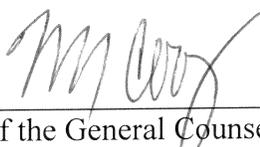
  
\_\_\_\_\_  
Office of the General Counsel

**FOR VENDOR**

(Corporate Seal)

SUPERIOR PARK SYSTEMS, INC.

Mitchell Leitner

ATTEST:

By *[Signature]*

\_\_\_\_\_, Secretary

-or-

*[Signature]*  
Witness

*[Signature]*  
Witness

**The Following Notarization is Required for Every Agreement Without Regard to Whether the Party Chose to Use a Secretary's Attestation or Two (2) Witnesses.**

STATE OF Florida

COUNTY OF Miami Dade

The foregoing instrument was acknowledged before me this 31<sup>st</sup> day of May, 2016 by Mitchell Leitner of

Name of Person

Superior Park Systems, Inc., on behalf of the corporation/agency.

Name of Corporation or Agency

He/She is personally known to me or produced \_\_\_\_\_ as identification and did/did not first take an oath. \_\_\_\_\_ Type of Identification

My Commission Expires:

*[Signature]*  
Signature – Notary Public

Caitlin Smith  
Printed Name of Notary

FF 960626  
Notary's Commission No.

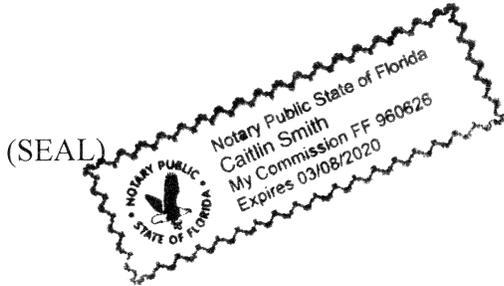

**School District of Palm Beach County FL**



**Invitation to Bid No.  
15C-32B**

**Playground Equipment, Outdoor Fitness Equipment, Surfacing, Fitness Trails and Fabric  
Shade Structures**

.....

**RESPONSES ARE DUE PRIOR TO:**

**2:00 PM (EST), May 27, 2015**

.....

**RESPONSES MUST BE SUBMITTED ELECTRONICALLY TO:**

[www.Demandstar.com](http://www.Demandstar.com)

.....

The School District of Palm Beach County is an  
Equal Education Opportunity Provider and Employer.  
[http://www.palmbeachschools.org/purchasing/documents/Equity Coordinators.pdf](http://www.palmbeachschools.org/purchasing/documents/Equity_Coordinators.pdf)

**15C-32B - SPECIAL CONDITIONS**

**A. SCOPE:** The purpose and intent of this Invitation to Bid is to secure prices and establish a Term Contract to Furnish and Install Playground Equipment, Outdoor Fitness Equipment, Surfacing, Fitness Trails and Fabric Shade Structures, as specified herein.

**B. DELIVERY:** Items in the Invitation to Bid are for various schools and departments located throughout Palm Beach County and are not for delivery to any central location. Awarded vendors for equipment are responsible for supplying all labor, materials, and equipment required for the off-loading and placement of items as directed, at all delivery locations, without assistance of School District personnel. A minimum of 48 hours advance notification of delivery is required from all freight carriers to the District's designated staff.

**C. DEMANDSTAR:**

1. All offers must be submitted electronically to Demandstar.com.
2. DemandStar requires that all documents be downloaded, completed, saved and re-uploaded to submit your offer. DemandStar does not support online document completion.
3. The Vendor Contact Information page on the DemandStar site has a required field "BID AMOUNT". The District does not require this field to be completed, but in order to complete the process DemandStar requires input. It is suggested that you input zero. All the District requirements should be included in number one above.
4. It is recommended that you incorporate your response into one document or as few separate uploads as possible when submitting your offer to DemandStar.
5. **The District will only consider offers that have been uploaded and submitted prior to the bid closing date and time. Allow sufficient time to complete your offer.**
6. **IMPORTANT INFORMATION:** When finished uploading all required documents, at the end of the document, **you must Submit your Response.**

After clicking "Submit Response" the following process will begin:

- DemandStar will verify that your response is complete as entered.
- You will see a confirmation page with your confirmation number and date/time stamp of your upload.
- You will receive a confirmation e-mail indicating a successful response submittal.

**If you do not receive any of the above, please call DemandStar Supplier Services at (800)711-1712 or email [demandstar@onvia.com](mailto:demandstar@onvia.com)**

**For additional information please go to:**

<http://www.palmbeachschools.org/purchasing/bids/purch/vendor/ebidding.pdf>

7. Hard copy bids will not be accepted.
8. Be advised that DemandStar has a limit of 30MB per document upload and a 100MB maximum per vendor response.

If necessary, an addendum will be distributed by DemandStar to all who are known by the Purchasing Department to have received a complete set of proposal documents.

- D. BENEFICIAL INTEREST AND DISCLOSURE OF OWNERSHIP AFFIDAVIT:** The School District is requesting this affidavit to include a list of every “person” (as defined in Section 1.01 (3), Florida Statutes to include individuals, children, firms, associates, joint adventures, partnerships, estates, trusts, business trusts, syndicates, fiduciaries, corporations and all other groups and combinations) holding 5% or more of the beneficial interest in the disclosing entity. **The Beneficial Interest and Disclosure of Ownership Affidavit (PBSD Form 1997) must be completed, signed, notarized and returned with your bid.**
- E. FLORIDA PREFERENCE:** Pursuant to §287.084 Florida Statute, award recommendations shall make appropriate adjustments to pricing when considering solicitations from Proposers having a principal place of business outside the State of Florida. **All Proposers must complete and submit the attached Proposers Statement of Principal Place of Business with the response to this solicitation.** Failure to comply may be considered non-responsive to the terms of this solicitation. Refer to <http://www.leg.state.fl.us/Statutes/index.cfm> for additional information regarding this Statute.
- F. M/WBE PREFERENCE:** Pursuant to Board Policy 6.143, award recommendations shall make appropriate adjustments to pricing when considering solicitations from a State of Florida or District certified Minority/Women Business Enterprise (M/WBE) if the bid price does not exceed the lowest bidder's price by an amount greater than \$50,000 or 5%, whichever is less. In instances where the certified M/WBE's price difference is greater than \$50,000 or 5%, the lowest responsive, responsible bidder will be awarded the contract and the goals shall be deemed waived. The requirements to qualify for the M/WBE are to be certified either by the State of Florida or the School District of Palm Beach County, **subject to the criteria indicated in paragraph P.** The District does not recognize any other certifications. Graduation (as described in Board Policy 6.143) from the District M/WBE Certification Program shall void certification by the State of Florida, if a vendor has exceeded the revenue/sales size standards for their industry specific classification for the previous three year period. **See Paragraph N, M/WBE GOAL for complete detail.** For District certification go to <http://www.palmbeachschools.org/MWBE> website and complete the M/WBE certification application.
- G. AWARD:** In order to meet the needs of the District, awards shall be made to all bidders found to be responsive and responsible and who offer a firm percentage discount for equipment, submit catalogs, agree to provide quotes as requested, and otherwise comply with all bid specifications, terms and conditions contained herein, including identifying their certified installer. That installer must respond to this bid. If the certified installer is found to be responsive and responsible and agrees to comply with all bid specifications and terms and conditions pertaining to installation and contained herein, the installer will be awarded on this bid. If the certified installer identified by the vendor responding only to the firm percentage discount for equipment section of this bid is not awarded, the vendor offering only discounts on equipment may be rejected.
- H. TERM OF CONTRACT:** The term of this contract shall be from August 20, 2015 through August 19, 2020. The contract may be extended ninety (90) days beyond the contract expiration date, if needed. The awardee agrees to this condition by signing their bid. The awardee will be notified by the Purchasing Department when the recommendation has been acted upon. All discount percentages and prices shall be firm for the term of this contract; however, nothing prohibits the District from accepting lower pricing during the term of this contract.

- I. REFERENCES:** Complete the Reference Document and include at least five (5) references from customers that you have contracted with to provide and/or install playground or outdoor fitness equipment, PIP surfacing, artificial turf, fabric shade structures or fitness trails

NOTE: The information requested must include a current contact name, and email address for each reference.

- J. QUALIFICATIONS:** Provide photocopies of the following (**valid and current**) licenses and/or certificates: **Failure to provide this documentation may result in rejection of bid.** Palm Beach County Local Business Tax Receipt, formerly Occupational License.

The bidder(s) must have an adequate organization, facilities, equipment, and personnel to insure prompt and efficient service. The District reserves the right, before recommending any award, to inspect the facilities to determine ability to perform. The District reserves the right to reject bids where evidence submitted, investigation and/or evaluation, is determined to indicate inability of the bidder to perform.

- K. PLACING AN OFFER:** All offers must be submitted electronically to Demandstar.com. No offer will be considered if submitted after the closing date and time. Hard copy bids will not be accepted.

Allow sufficient time to complete your offer, **and follow all steps outlined in Paragraph C.**

If necessary, an addendum will be distributed by DemandStar to all who are known by the Purchasing Department to have received a complete set of proposal documents.

- L. BID QUESTIONS:** Any questions concerning conditions and specifications must be submitted by email to Karen L. Adducci at [Karen.Adducci@palmbeachschools.org](mailto:Karen.Adducci@palmbeachschools.org) no later than 5:00 p.m. EST, on May 15, 2015. Questions received in writing by the time and date specified will be answered in writing and posted on DemandStar. Mrs. Adducci is authorized only to direct the attention of prospective proposers to various portions of the Bid so that they may read and interpret such for themselves. Neither Mrs. Adducci nor any employee of the District is authorized to interpret any portion of this Bid or give information as to the requirements of the Bid in addition to that contained in the written documents.

All questions submitted (along with their source) are subject to Public Records Laws and as such will be available for inspection upon receipt of a Public Records Request.

- M. POSTING OF BID RECOMMENDATION / TABULATIONS:** Bid recommendations and tabulations will be posted electronically with DemandStar and at the Fulton Holland Educational Services Center Purchasing Department, at 3300 Forest Hill Boulevard, Third Floor, A-Wing Suite A-323 West Palm Beach, FL, for review by interested parties, on June 11, 2015, at 3:00 p.m., EST, and will remain posted for a period of 72 hours. If the bid tabulation with recommended awards is not posted by said date and time, A "Notice of Delay of Posting" will be posted to inform all bidders of the new posting date and time.

Any person adversely affected by the decision or intended decision, as defined in School Board Policy 6.14 (4) (a), must file a notice of protest, in writing, within 72 hours after the posting of the notice of decision or intended decision. Saturdays, Sundays and State Holidays shall be excluded in the computation of the 72-hour time period. The formal written protest must be filed within 10 days after the date the notice of protest is filed. The formal written protest shall state with particularity the facts and law upon which the protest is based. Failure to file a notice of protest or to file a formal written protest within the time prescribed in section 120.57 (3), Florida Statutes, shall constitute a waiver of proceedings under chapter 120, Florida Statutes.

- N. M/WBE GOAL:** The Goal Setting Committee has established a 5% bid preference for participation/utilization of Minority/Women's Business Enterprises.

The Board strongly encourages the use of Minority/Woman Owned Business Enterprises for participation as partners, joint-venturers, prime contractor, sub-contractors, and in contracting opportunities. Listings of District Certified Minority and Women Business Enterprises can be found on the District's Office of Diversity in Business Practices web site at <http://www.palmbeachschools.org/mwbe/>.

- O. SUB-CONTRACTING:** If a vendor intends to sub-contract any portion of this bid for any reason, the name and address of the subcontracting firm must be submitted with the bid or prior to use for approval. No sub-contracting will take place prior to bid-awarded vendor furnishing this information and receiving written approval from the District. Subcontractors will be required to conform to the Jessica Lunsford Act as noted in the Instructions to Bidders document of this bid.

The Purchasing Department reserves the right to reject a subcontractor who previously failed in the proper performance of an award or failed to deliver on-time contracts of a similar nature, or who is not in the position to perform this award. The School District Representative reserves the right to inspect all facilities of any subcontractor in order to make determination as to the foregoing. The subcontractor will be equally responsible for meeting all requirements specified in this Invitation to Bid. Vendors are encouraged to seek minority and women business enterprises for participation in sub-contracting opportunities. The sub-contractor shall be equally responsible for meeting all requirements specified in this Invitation to Bid.

- P. MINORITY BUSINESS PARTICIPATION:**

Bidders who list minority subcontractors as participants in their bids will complete the M/WBE SUBCONTRACTOR PARTICIPATION LETTER OF INTENT (FORM 1525) and M/WBE SUBCONTRACTOR PARTICIPATION SUMMARY (FORM 1526). The summary (FORM 1526) will be submitted with all requests for payment.

The District only recognizes as acceptable for certification as minority/woman business enterprises those firms, vendors, and consultants that have successfully completed the certification requirements of the State of Florida Office of Supplier Diversity or the School District of Palm Beach County's Office of Diversity in Business Practices. The letter or certificate will only be deemed valid if the dates for certification have not expired. Any pending application with the District or the State of Florida Office of Supplier Diversity shall not be considered as certification of the vendor making application for consideration as a M/WBE firm.

In order to receive consideration for M/WBE participation, the bidder or firm(s) to be utilized by the bidder must be certified by the District or the State of Florida at the time that the bid is opened.

The District does not currently by implication or direct means have reciprocity with any governmental or non-governmental entity, with the exception of the State of Florida Office of Supplier Diversity for the purpose of sharing and/or acceptance of M/WBE vendors, consultants, for certification. The District does not recognize any other certifications.

Graduation (as described in School Board of Palm Beach County Policy 6.143) from the School District M/WBE Certification shall void certification by the State of Florida. Certification shall be verified and point award shall be determined by the Office of Diversity in Business Practices.

**Industry Specific Classifications:**

To ensure compliance with program guidelines and intent, proposers/subcontractors presenting State of Florida certification will receive MWBE bid preference ONLY if their specific MWBE classification is consistent with, and meets the standards identified in the Industry Specific Classifications and thresholds contained in School Board Policy 6.143 and the Office of Diversity in Business Practices' Procedures Manual.

**The industry specific classification for this solicitation is:**

- General Procurement- Asian and Native American owned

**Revenue/ Sales Size Standards for Industry Specific Classifications:**

Any firm that has exceeded gross sales or revenues (averaged over the last three (3) years) greater than the amounts below shall not be considered eligible to participate in the School District's M/WBE program.

- \$3,000,000 (Three Million dollars) for General Procurement

**To verify eligibility of State of Florida M/WBE Certified Vendors:** Bidders shall include in their bid response notarized copies of the front page of their or their subcontractor's tax return for the previous three years. **Failure to do so will result in denial of M/WBE bid preference for utilization of State of Florida certified M/WBE bidders/subcontractors.**

**Q. ACCESSIBILITY TO AND COOPERATION WITH INSPECTOR GENERAL AND STAFF:**

The Awarded Vendor agrees and understands that the School District's Office of Inspector General shall have immediate, complete, and unrestricted access to all financial and performance-related records, papers, books, documents, information, writings, drawings, graphs, photographs, processes, data or data compilations, computer hard drives, emails, instant messages, services, and property or equipment purchased in whole or in part with School Board funds ("Information and Records"). The Awarded Vendor shall furnish the Inspector General with all Information and Records requested for the purpose of conducting an investigation or audit, as well as provide the Inspector General with reasonable assistance in locating assets and obtaining Information and Records that are in the possession, custody, or control of the Awarded Vendor or its subcontractor. The Awarded Vendor understands, acknowledges, and agrees to abide by applicable portions of School Board Policy 1.092. Such policy is located at: <http://www.palmbeachschools.org/policies/>.

**R. PUBLIC RECORDS LAW**

The Contractor will be required by contract to:

- 1) Keep and maintain public records that ordinarily and necessarily would be required by the public agency in order to perform the service.
- 2) Provide the public with access to public records on the same terms and conditions that the public agency would provide the records and at a cost that does not exceed the cost provided in this chapter or as otherwise provided by law.
- 3) Ensure that public records that are exempt or confidential and exempt from public records disclosure requirements are not disclosed except as authorized by law.
- 4) Meet all requirements for retaining public records and transfer, at no cost, to the public agency all public records in possession of the contractor upon termination of the contract and destroy any duplicate public records that are exempt or confidential and exempt from public records disclosure requirements. All records stored electronically must be provided to the public agency in a format that is compatible with the information technology systems of the public agency.

**Public Records Exemption:**

- 1) For purposes of this paragraph, “competitive solicitation” means the process of requesting and receiving sealed bids, proposals, or replies in accordance with the terms of a competitive process, regardless of the method of procurement.
- 2) Sealed bids, proposals, or replies received by an agency pursuant to a competitive solicitation are exempt from s. 119.07(1) and s. 24(a), Art. I of the State Constitution until such time as the agency provides notice of an intended decision or until 30 days after opening the bids, proposals, or final replies, whichever is earlier.
- 3) If an agency rejects all bids, proposals, or replies submitted in response to a competitive solicitation and the agency concurrently provides notice of its intent to reissue the competitive solicitation, the rejected bids, proposals, or replies remain exempt from s. 119.07(1) and s. 24(a), Art. I of the State Constitution until such time as the agency provides notice of an intended decision concerning the reissued competitive solicitation or until the agency withdraws the reissued competitive solicitation. A bid, proposal, or reply is not exempt for longer than 12 months after the initial agency notice rejecting all bids, proposals, or replies.

**S. INSURANCE REQUIREMENTS:** Proof of the following insurance will be furnished by the awarded vendor(s) to the School Board of Palm Beach County by Certificate of Insurance.

Original copies of Certificates of Insurance meeting the specific required provision specified within this contract/agreement shall be forwarded to the School District of Palm Beach County, Purchasing Department by email ([insurancecertificate@palmbeachschools.org](mailto:insurancecertificate@palmbeachschools.org)), or fax (561-963-3823), and approved prior to the start of any work or the possession of any school property. Renewal certificates must be forwarded to the same department prior to the policy renewal date.

Thirty days written notice must be provided to the School District of Palm Beach County via certified mail in the event of cancellation. The notice must be sent to the Purchasing Department.

The awarded vendors shall provide complete copies of any insurance policy for required coverage within seven days of the date of request by the Purchasing Department. For all contracts with an amount of \$500,000 or more the actual INSURANCE POLICY must be included with the Certificate of Insurance.

1. **WORKERS' COMPENSATION:** Bidder(s) must comply with FSS 440, Workers' Compensation and Employees' Liability Insurance with minimum statutory limits.
2. **COMMERCIAL GENERAL LIABILITY:** Awarded vendors shall procure and maintain, for the life of this contract/agreement, Commercial General Liability Insurance. This policy shall provide coverage for death, bodily injury, personal injury, products and completed operations liability and property damage that could arise directly or indirectly from the performance of this agreement. It must be an occurrence form policy. **THE SCHOOL BOARD OF PALM BEACH COUNTY SHALL BE NAMED AS AN ADDITIONAL INSURED ON THE CERTIFICATE FOR COMMERCIAL GENERAL LIABILITY INSURANCE.**

The minimum limits of coverage shall be \$1,000,000 per occurrence, Combined, Single Limit for Bodily Injury Liability and Property Damage Liability.

3. **BUSINESS AUTOMOBILE LIABILITY:** Awarded vendors shall procure and maintain, for the life of the contract/agreement, Business Automobile Liability Insurance. **THE SCHOOL BOARD OF PALM BEACH COUNTY SHALL BE NAMED AS AN ADDITIONAL INSURED ON THE CERTIFICATE FOR BUSINESS AUTOMOBILE LIABILITY INSURANCE.**

The minimum limits of coverage shall be \$1,000,000 per occurrence. This coverage shall be an "Any Auto" form policy or a form policy that includes "Scheduled Autos, Hired Autos, and Non-Owned Autos" coverage. The insurance must be an occurrence form policy.

In the event the contractor does not own any vehicles, we require an affidavit signed by the contractor indicating the following:

\_\_\_\_\_ (Company Name) does not own any vehicles. In the event we acquire any vehicles throughout the term of this contract/agreement, \_\_\_\_\_ (Company Name) agrees to purchase Business Automobile Liability coverage as indicated above on the date of acquisition.

4. **WAIVER OF SUBROGATION:** In the event of loss, damage or injury to the awarded bidder(s) and/or the awarded bidder's property, the awarded bidder(s) shall look solely to any insurance in its favor without making any claim against the School Board of Palm Beach County. The awarded bidder(s) hereby waives any right of subrogation against the School Board of Palm Beach County, for loss, damage or injury within the scope of the Performer's insurance, and on behalf of itself and its insurer, waives all such claims against the School Board of Palm Beach County.

NOTE: The terms and conditions of this agreement shall apply with respect to awarded bidder's operations for any school or ancillary owned by the School Board of Palm Beach County.

- I. PAYMENT / PAYMENT TERMS:** Payment will be made after the goods/services from the awarded vendor have been received/completed; inspected and found to comply with award specifications, free of damage or defect; and a properly billed invoice is received and processed in the Accounting Services Department.

The District's payment terms are net 30 days; however, the District will accept terms for early payment. See **Early Payment Terms Document**.

**Payment will not be processed until the following occurs:**

1. The complete and satisfactory receipt of all items ordered. All pricing in accordance with the bid.
2. The receipt of a properly billed invoice in the Accounting Services Department.

**Invoices to the School Board MUST include the following to permit verification of prices and expedite payment to vendors:**

1. Name and Address of Vendor
2. A Unique Invoice Number
3. Date of Shipment
4. Line Item Total or Extended Price
5. Purchase Order Number
6. A copy of the first invoice for this contract shall be sent to the Purchasing Agent for review at [karen.adducci@palmbeachschools.org](mailto:karen.adducci@palmbeachschools.org)

**Invoice copy and/or packing slip must be presented at time of delivery. Original Invoice must be sent to Accounting Services, 3300 Forest Hill Blvd., Suite A-323, West Palm Beach, FL 33406, or submitted electronically.**

To submit an invoice as an email attachment, ensure that the electronic document meets the guidelines below and email the invoice to [apinvoice@palmbeachschools.org](mailto:apinvoice@palmbeachschools.org). That's it. Instead of waiting a few days for us to receive your invoice, we can start processing it as soon as we receive it.

**Electronic Invoice Submission Guidelines:**

- a. Submit industry standard PDF's, created at a 300-dpi bi-tonal equivalent (either image or text only content) or bi-tonal or grey scale TIF's.
- b. Each invoice must be its own file attachment. Multiple invoices in a single email is supported, but each invoice must be a separate file attachment

If you are interested in learning more about submitting invoices via email, please contact Bob Rucinski at [bob.rucinski@palmbeachschools.org](mailto:bob.rucinski@palmbeachschools.org), or call him at (561) 434-8701.

**Failure to timely submit invoices(s) to Accounting Services as set forth above may significantly delay processing and payment of the invoice.**

**The School Board may not process invoices submitted more than 120 Days after the date the goods or services were delivered without prior approval from the Accounting Services Department.**

**Vendor waives claims for payment of goods and/or services on invoice(s) not received by the Accounting Services Department within 120 Days of the delivery. Prior approval by Accounting Services is required if invoicing will extend past 120 days.**

**The above terms and conditions are agreed to by submitting an offer on this bid.**

- U. INCORRECT PRICING/INVOICES:** Any pricing on invoices that is incorrect or freight charges that were not included on the original Purchase Order, must be brought to the attention of the Purchasing Agent and corrected prior to the shipment(s) of goods or initiation of services. Additional costs that were not brought to the District's attention and did not receive written approval via a Change Order issued by the Purchasing Agent may not be honored.
- V. CHANGE ORDERS:** Any addition(s) to the Scope of Work or to a Purchase Order as a result of the bid award that adds additional costs must be brought to the School Districts attention and approved by the Purchasing Department prior to commencement of additional work, shipment of goods or the addition of unauthorized freight charges. Once approved, a Change Order will be issued to include the additional costs and work may commence and/or shipment of goods can begin. Additional costs that were not brought to the district's attention and did not result in a Change Order approved by the Purchasing Agent may not be honored.
- W. DISTRICT PURCHASING CARD:** The School District has authorized the use of a Purchasing Card with Visa through the Bank of America to expedite small dollar purchases for materials, supplies, and other items needed for daily operations. Vendors may be presented these credit cards by authorized School District personnel for the above mentioned purchases. Each cardholder's authorization limit may not exceed \$1,000 daily per vendor effective July 1, 2006 (with the exception of travel). Purchase orders are strongly discouraged for purchasing materials, and supplies under \$1,000.
- X. ORGANIZATION PROFILE:** Provide the Corporate Name and Parent Company (if applicable) and address of corporate headquarters. Provide the names, titles, addresses, email and telephone numbers of the persons authorized to answer any questions related to Company's proposal. The Organization Profile should also include information such as number of years in the business, number of locations, location of facilities, company vision statement and a succinct history of the company. In addition the Beneficial Interest and Disclosure of Ownership Affidavit (PBSD Form 1997) must be completed, signed, notarized and returned with your bid.
- Y. COMPANY FINANCIALS:** Vendors must provide financial statements giving the District enough information to determine financial stability. These statements may include, but are not limited to:
- a. Balance Sheet or Annual Report for the last three (3) years
  - b. Three (3) years of income statements and related earnings
  - c. Statement of Changes in financial position
  - d. Letter from the proposer banking institution
  - e. Statement from certified public accounting firm

**Z. ESTIMATED DOLLAR VALUE:** No guarantee of the dollar amount of this bid is implied or given.

**AA. WARRANTY:** Supplier/installer shall guarantee entire installed system to be free of defects in workmanship and materials for no less than one year from date installation is accepted. Supplier and/or installer shall repair and/or replace, at no cost to the School District, any defects or malfunctions noted during the warranty period and shall in addition transfer any manufacturer's guarantee for supplier/installer furnished equipment extending beyond this contract period to the owner. Supplier shall provide the manufacturer's warranty in writing and certified to the District's designee upon final inspection.

**BB. SALES PROMOTION / PRICE REDUCTION:** It is understood that sales promotions occur during the course of this contract that will lower prices of products for the period of the sales promotion. The District shall receive the full benefit of such reductions if lower than the discount established by this bid. The Purchasing Department must be notified of these promotions in writing, specifying the beginning and ending dates of the sales promotion.

Successful bidder(s) may always offer the District an additional discount at any time and invoice the District at a lower cost. Price reductions announced by the vendor shall take effect immediately and be applied to unshipped and subsequent orders.

**CC. HOURS OF OPERATION:** The installer is advised that the normal installation of these units shall occur when school is in session. It shall be the installer's responsibility to perform necessary measures, which may include erection of barricades and signs to isolate their work site and minimize the possibility of injury to staff and students. Additionally, it shall be the responsibility of the contractor to secure the area to protect their equipment and tools as well as to protect surfacing or foundation after it is poured and the playground components until the final inspection and acceptance by the District. There shall be no cost to the District for these safety and security measures.

**BID PREPARATION CHECKLIST:** The Bid Preparation Checklist is a guide to assist the Bidder in verifying the completeness of their Bid. The Bid Preparation Checklist does not relieve the Bidder of the responsibility of ensuring that all requirements of this solicitation are included with submittal of their response. Items checked "required" must be submitted with your bid response or your bid may be declared non responsive.

Verified by Vendor	Required	Document	See Special Condition
	Yes	Bidder Acknowledgement	N/A
	Yes	Bid Summary Document	N/A
	Yes	Certificates/License	Paragraph J
	Yes	Beneficial Interest and Disclosure of Ownership Affidavit	Paragraph D
	Yes	Proposer's Statement of Principal Place of Business	Paragraph E
	Yes	Debarment Certification	N/A
	Yes	Reference Document	Paragraph I
	Yes (if applicable)	Form 1525, Letter of Intent – M/WBE Subcontractor Participation	Paragraph P
	Yes (if applicable)	Form 1526, M/WBE Subcontractor Participation Summary	Paragraph P
	Yes	Form 0580, Drug-Free Workplace Certification	N/A
	Yes	Organizational Profile	Paragraph X
	Yes	Company Financials	Paragraph Y

## **INSTRUCTIONS TO BIDDERS**

The General Conditions for Bids, Instructions to Bidders, Special Conditions, Specifications, Addenda, and/or any other pertinent documents form a part of the Invitation to Bid, and by reference are made a part thereof.

1. **PURPOSE:** It is the purpose and intent of this invitation to secure bids for item(s) and/or services as listed herein for The School Board of Palm Beach County, Florida (hereinafter referred to as the "Board"), the corporate body politic that governs, operates, controls, and supervises the School District of Palm Beach County, Florida (hereinafter referred to as "District").
2. **ANTI-COLLUSION:** By electronically submitting a bid, the bidder certifies that it has not divulged, discussed or compared its bid with other bidders and has not colluded with any other bidder or parties to a bid whatsoever. No premiums, rebates or gratuities are permitted either with, prior to, or after any delivery of materials. Any such violation will result in the cancellation and/or return of materials (as applicable) and the removal of the bidder from all bid lists for the School Board of Palm Beach County, Florida.
3. **ANTI-DISCRIMINATION:**
  - a. The bidder certifies that they are in compliance with the non-discrimination clause contained in Section 202, Executive Order 11246, as amended by Executive Order 11375 relative to equal employment opportunity for all persons without regard to race, color, religion, sex or national origin. The provisions of the ADA Act of 1990 pertaining to employment shall also be applicable.
  - b. The bidder shall not discriminate on the basis of race, gender, gender identity or expression, religion, national origin, ethnicity, sexual orientation, age or disability in the solicitation, selection, hiring, or treatment of sub-contractors, vendors, suppliers, or commercial customers. Bidder shall provide equal opportunity for sub-contractors to participate in all of its public sector and private sector sub-contracting opportunities, provided that nothing contained in this clause shall prohibit or limit otherwise lawful efforts to remedy the effects of marketplace discrimination that has occurred or is occurring in the marketplace, such as those specified in the Palm Beach County School Board Policy 6.143. Bidder understands and agrees that violation of this clause is a material breach of the contract and may result in contract determination, debarment, or other sanctions.
4. **BIDS:** Bids will be received electronically through a secure mailbox at Demandstar.com until the date and time as indicated in this bid document. Bids will be opened publicly at the School District of Palm Beach County, Purchasing Department, 3300 Forest Hill Boulevard, Suite A-323, West Palm Beach, FL 33406-5813, and all bidders and general public are invited to attend. It is the sole responsibility of the bidder to ensure its bid reaches Demandstar on or before the closing date and hour as indicated in this bid document.
5. **CONTRACT:** The submission of your bid constitutes a firm offer by the bidder. Upon acceptance by the Board, the Purchasing Department will issue a notice of award and purchase order(s) for any supplies, equipment and/or services as a result of this bid. The Invitation to Bid and the corresponding purchase order(s) will constitute the complete agreement between the successful bidder and the Board. Unless otherwise stipulated in

the bid documents or agreed to in writing by both parties, no other contract documents shall be issued or accepted.

6. **WITHDRAWAL:** When a bidder wishes to withdraw a bid, a written request shall be submitted to the Director of Purchasing and the request will be reviewed for consideration. In no case shall a bidder be granted a release from a bid more than one time in a two-year period. A bidder may not withdraw a bid after the final call for bids at a designated time of opening.
7. **DEFAULT:** In case of default by the bidder, the Board may procure the articles or services from other sources and hold the bidder responsible for any excess costs incurred thereby.
8. **FUNDING OUT/ CANCELLATION OR TERMINATION WITH OR WITHOUT CAUSE:**

A. With Cause: In the event any of the provisions of the Contract are violated by the bidder, the Superintendent or designee shall give written notice to the bidder stating the deficiencies and unless the deficiencies are corrected within ten days, recommendation will be made to the Board or its designee for immediate cancellation. Upon cancellation hereunder the Board may pursue any and all legal remedies as provided herein and by law. In the event that it is subsequently determined that a cancellation under this paragraph was incorrect, the termination shall be converted to a termination for convenience pursuant to the next paragraph.

B. Without Cause: The Board or its designee reserves the right to terminate any contract resulting from this Invitation to Bid at any time and for no reason whatsoever, upon giving 30 days prior written notice to the bidder. If the Contract should be terminated for convenience as provided herein, the Board shall be relieved of all obligations under said Contract. The Board or its designee shall only be required to pay to the successful bidder that amount of the Contract actually performed to the date of termination.

C. Funding Out: Florida School Laws prohibit the Board or its designee from creating obligations on anticipation of budgeted revenues from one fiscal year to another without year-to-year extension provisions in the contracts.

It is necessary that fiscal funding out provisions be included in all bids in which the terms are for periods of longer than one year.

Therefore, the following funding out provisions are an integral part of this Invitation to Bid and must be agreed to by all bidders:

The Board or its designee may, during the contract period, terminate or discontinue the items covered in this bid for lack of appropriated funds upon the same terms and conditions.

Such prior written notice will state:

1. That the lack of appropriated funds is the reason for termination, and
2. Board agrees not to replace the equipment or services being terminated with equipment and services with functions similar to those performed by

the equipment covered in this bid from another vendor in the succeeding funding period.

**“This written notification will thereafter release the School Board of Palm Beach County, Florida of all further obligations in any way related to such equipment covered herein”.**

9. When any of the parties desire to give notice to the other, such notice must be in writing, sent by U.S. Mail/Federal Express/United Parcel Service or other traceable method, postage prepaid, addressed to the party for whom it is intended at the place last specified. The place for giving notice shall remain such until it is changed by written notice in compliance with the provisions of this paragraph. For the present, the Parties designate the following as the respective places for giving notice:

To School Board: Director of Purchasing Department  
The School District of Palm Beach County  
3300 Forest Hill Blvd., Suite A323  
West Palm Beach, FL 33406

With a copy to: Inspector General  
The School District of Palm Beach County  
3300 Forest Hill Blvd., Suite C306  
West Palm Beach, FL 33406

To Contractor:

10. **BIDDERS RESPONSIBILITY:** Before submitting its bid, each bidder is required to carefully examine the Invitation to Bid delivery schedule, bid prices and extensions, insurance requirements, licensing requirements, bid closing date and time and to completely familiarize itself with all of the terms and conditions that are contained within the Invitation to Bid. Failure to do so on the part of the bidder will in no way relieve it of any of the obligations and responsibilities which are a part of the Invitation to Bid.

Bidder warrants by virtue of bidding that prices shall remain firm for a period of ninety (90) days from the date of award by the Board or time stated in special conditions.

11. **AWARDS:** In the best interest of the District, the Purchasing Department reserves the right to reject any and all bids and to waive any minor irregularity in bids received; to accept any item or group of items unless qualified by bidder; to acquire additional quantities at prices quoted on the Invitation to Bid unless additional quantities are not acceptable, in which case the bid sheets must be noted "BID IS FOR SPECIFIED QUANTITY ONLY". All awards made as a result of this bid shall conform to applicable Florida Statutes.

12. **THE JESSICA LUNSFORD ACT:** All awarded bidders who are permitted access on school grounds when students are present, who may have direct contact with any student of the District, or who may have access to or control of school funds must be fingerprinted and background checked. Awarded bidder agrees to undergo a background check and fingerprinting if he/she is an individual who meets any of the above conditions and to require that all individuals in the organization who meet any of the conditions to submit to a

Level 2 FDLE background check and FBI screening, including fingerprinting by the School District's Police Department, at the sole cost of Awarded bidder. The report of the results will be immediately transmitted to the School District's Police Department, which shall be the sole determiner of clearance. Awarded bidder shall not begin providing services contemplated by the Invitation to Bid until Awarded bidder receives notice of clearance by the School District and is issued School District badges. Compliance requiring all awarded bidders to register as a visitor before entering school property and proper display of School District badges will be strictly enforced. Neither the Board, nor its members, officers, employees, or agents, shall be liable under any legal theory for any kind of claim whatsoever for the rejection of Awarded bidder (or discontinuation of Awarded bidder's services) on the basis of these compliance obligations. Awarded bidder agrees that neither the Awarded bidder, nor any employee, agent or representative of the Awarded bidder who has been convicted or who is currently under investigation for a crime delineated in section 435.04, Florida Statutes, will be employed in the performance of the contract.

13. **DISQUALIFYING CRIMES:** The bidder certifies by submission of this bid, that neither it nor its principals is presently debarred, suspended, proposed for debarment, declared ineligible or voluntarily excluded from participation in this transaction by the State of Florida or Federal Government. Further, bidder certifies that it has divulged, in its bid response, information regarding any of these actions or proposed actions with other governmental agencies.

A person or affiliate who has been placed on the convicted vendor list following a conviction for a public entity crime may not submit a bid to provide any goods or services to a public entity, may not submit a bid to contract with a public entity for the construction or repair of a public building or public work, may not submit bids on leases of real property to a public entity, may not be awarded or perform work as a contractor, supplier, subcontractor, or consultant under a contract with any public entity, and may not transact business with any public entity in excess of the threshold amount provided in Section 287.017, Florida Statutes, for CATEGORY TWO for a period of 36 months from the date of being placed on the convicted vendor list.

The bidder(s) certifies by submission of this bid, that neither it nor its principals are presently debarred, suspended, proposed for debarment, declared ineligible, or voluntarily excluded from participation in this transaction by any State or Federal department/agency.

The awarded bidder or any subcontractor shall not employ any persons with multiple felonies and / or crimes against children. The awarded bidder must provide documented proof of efforts to comply with this requirement. The Owner may declare any non-compliance or lack of diligent effort by the awarded bidder to comply as a breach of contract and immediately terminate the services of the awarded bidder.

14. **ADVERTISING:** In submitting a bid, bidder agrees not to use the results therefrom as a part of any commercial advertising without prior approval of the District.
15. **LOBBYING:** Bidders are hereby advised that they are not to lobby with any district personnel or board members related to or involved with this bid until the administration's recommendation for award has been posted at Demandstar.com, and at the Fulton Holland Educational Services Center, Purchasing Department area. All oral or written inquiries must be directed through the Purchasing Department.

Lobbying is defined as any action taken by an individual, firm, association, joint venture, partnership, syndicate, corporation, and all other groups who seek to influence the governmental decision of a board member or district personnel after advertisement and prior to the posted recommendation on the award of the Contract.

Any bidder or any individuals that lobby on behalf of bidder during the time specified will result in rejection / disqualification of said bid.

16. **DISPUTES:** In case of any doubt or difference of opinion as to the items to be furnished hereunder, the decision of the Board shall be final and binding on both parties.
17. **LEGAL REQUIREMENTS:** Federal, state, county, and local laws, ordinances, rules, and regulations that in any manner affect the items covered herein apply. Specifically, bidder(s) is to adhere to School Board Policies 3.12 and 3.13, pursuant to the following, with respect to any criminal arrests and convictions, and is on notice thereto that any employees involved in any Chapter [435](#), Florida Statutes offenses are precluded from continuing to work on the project and must be replaced. Failure to comply may result in the immediate termination of the awarded bidder's contract at the sole discretion of the District. Lack of knowledge by the bidder will in no way be a cause for relief from responsibility.
18. **TAXES:** The School District of Palm Beach County, is exempt from any taxes imposed by the State and/or Federal Government. State Sales Tax Exemption Certificate No. 85-8013897253C-1 and Federal Excise Tax No. 59-600783 appears on each purchase order. This exemption does not apply to purchase of tangible personal property made by contractors who use the tangible personal property in the performance of contracts for the improvements of School District-owned real property as defined in Chapter 192, Florida Statutes.
19. **ASSIGNMENT:** The successful bidder shall not sub-contract, assign, transfer, convey, sublet, or otherwise dispose of the contract, or of any or all of its rights, title, or interest therein, or its power to execute such contract to any person, firm, or corporation without prior written consent of the Board.
20. **SUBCONTRACTING:** If an awarded bidder intends to subcontract any portion of the Contract for any reason, the name and address of the subcontracting firm must be submitted along with the bidder's bid or prior to use for approval. No subcontracting will take place prior to bid-awarded bidder furnishing this information and receiving written approval from the District.

The Purchasing Department reserves the right to reject a subcontractor who previously failed in the proper performance of a contract or failed to deliver on-time contracts of a similar nature, or who, the District has determined in its sole discretion, is not in the position to perform the contract due to the subcontractor's size, experience, or resources. The District reserves the right to inspect all facilities of any subcontractor in order to make determination as to the foregoing. The subcontractor will be equally responsible for meeting all requirements specified in the Invitation to Bid.

21. **DEBARMENT:** The Board shall have the authority to debar a person / corporation for cause for consideration or award of future contracts. The debarment shall be for a period commensurate with the seriousness of the causes, generally not to exceed three (3) years. When the offense is willful or blatant, a longer term of debarment may be imposed, up to an indefinite period.
22. **REQUIREMENTS FOR PERSONNEL ENTERING DISTRICT PROPERTY:** Possession of firearms will not be tolerated in or near school buildings; nor will violations of Federal and State laws and any applicable Board policy regarding Drug Free Workplace be tolerated. Violations will be subject to the immediate termination provision heretofore stated in Paragraph 16, Legal Requirements.

"Firearm" means any weapon (including a starter gun or antique firearm) which will, is designed to, or may readily be converted to expel a projectile by the action of an explosive; the frame or receiver of any such weapon; any destructive device; or any machine gun.

No person who has a firearm in their vehicle may park their vehicle on District property. Furthermore, no person may possess or bring a firearm on District property.

If any employee of an independent contractor or sub-contractor is found to have brought a firearm on District property, said employee must be terminated from the Board project by the independent contractor or sub-contractor. If the sub-contractor fails to terminate said employee, the sub-contractor's agreement with the independent contractor for the Board project shall be terminated. If the independent contractor fails to terminate said employee or fails to terminate the agreement with the sub-contractor who fails to terminate said employee, the independent contractor's agreement with the Board shall be terminated.

Bidders are advised that they are responsible to ensure that no employee, agent or representative of their company who has been convicted or who is currently under investigation for a crime against children in accordance with section 435.04, Florida Statutes, will enter onto any school site.

23. **PRODUCT RECALL:** In the event the awarded awarded bidder receives notice that a product delivered by the awarded bidder to the District has been recalled, seized or embargoed, and/or has been determined to be misbranded, adulterated, or found to be unfit for human consumption by a packer, processor, subcontractor, retailer, manufacturer, or by any State or Federal regulatory agency, the awarded bidder shall notify the District's Bid Purchasing Agent within two business days of receiving such notice. The District's acceptance or failure to reject the affected product as non-conforming shall not in any way impact, negate, or diminish the awarded bidder's duty to notify the District's Purchasing Agent that the affected product has been recalled, seized or embargoed, and/or has been determined to be misbranded, adulterated, or found to be unfit for human consumption. The form and content of such notice to the District shall include the name and description of the affected product; the approximate date the affected product was delivered to the District; the bid number; and relevant information relating to the proper handling of the affected product and/or proper disposition of the affected product by the District, if necessary to protect the health, welfare, and safety of District students or employees; and any health hazards known to the awarded bidder which may be caused or created by the affected product. The awarded bidder shall, at the option of the Purchasing Department and/or Purchasing Agent, either reimburse the purchase price or provide an equivalent replacement product at no additional cost to the District. Unless it was absolutely necessary for the District to dispose of the affected product, the awarded bidder shall be responsible for removal and/or replacement of the affected product within a reasonable time, as determined by the District, without causing significant inconvenience to the District.

At the option of the District, the awarded vendor may be required to reimburse storage and/or handling fees to be calculated from time of delivery and acceptance to actual removal or disposal. The awarded vendor will bear all costs associated with the removal and proper disposal of the affected product. The failure to reimburse the purchase price and storage and/or handling fees or to remove and/or replace the affected product with an equivalent replacement within a reasonable time without significant inconvenience to the District will be considered a default.

**GENERAL CONDITIONS FOR BIDS**

1. **USE OF OTHER CONTRACTS:** The District reserves the right to utilize any other District contract, any State of Florida Contract, any contract awarded by any other city or county governmental agencies, any other school board, any other community college/state university system cooperative bid agreement, or to directly negotiate/purchase per School Board policy and/or State Board Rule 6A-1.012(6) in lieu of any offer received or award made as a result of this bid, if it is in the best interest to do so. The District also reserves the right to separately bid any single order or to purchase any item on this bid if it is in its best interest to do so.
2. **JOINT-BIDDING, COOPERATIVE PURCHASING AGREEMENT:** All bidders submitting a response to this Invitation to Bid agree that such response also constitutes a bid to all State Agencies and Political Subdivisions of the State of Florida under the same conditions, for the same prices and for the same effective period as this bid, should the bidder(s) deem it in the best interest of their business to do so.

This agreement in no way restricts or interferes with any state agency or political subdivision of the State of Florida to rebid any or all items.

3. **FAILURE TO DELIVER:** Failure to deliver as specified and at bid price will authorize the Board to purchase these items or services from other sources and hold the bidder responsible for any excess costs incurred thereby. Further, the Purchasing Department may recommend to the School Board that the vendor failing to deliver as specified be removed as a future bidder on all bids for a period of up to three years.
4. **MANDATORY NONDISCRIMINATION CLAUSE:** The Bidder shall not discriminate on the basis of race, gender, gender identity or expression, religion, national origin, ethnicity, sexual orientation, age or disability in the solicitation, selection, hiring, or treatment of sub-contractors, vendors, suppliers, or commercial customers. The Bidder shall provide equal opportunity for sub-contractors to participate in all of its public sector and private sector sub-contracting opportunities, provided that nothing contained in this clause shall prohibit or limit otherwise lawful efforts to remedy the effects of marketplace discrimination that has occurred or is occurring in the marketplace, such as those specified in the Palm Beach County School Board Policy 6.143. The Bidder understands and agrees that violation of this clause is a material breach of the contract and may result in contract determination, debarment, or other sanctions.
5. **CONTRACTOR BID REQUIREMENTS:** As part of its bid, bidder shall provide to the District a list of all instances within the past ten years where a complaint was filed or pending against bidder in a legal or administrative proceeding alleging that bidder discriminated on the basis of race, gender, gender identity or expression, religion, national origin, ethnicity, sexual orientation, age, or disability against its subcontractors, vendors, suppliers, or commercial customers, and a description of the status or resolution of each such complaint, including any remedial action taken.
6. **CONTRACT DISCLOSURE:** Upon the District's request, and upon the filing of a complaint against awarded bidder pursuant to Palm Beach County School Board Policy 6.144, awarded bidder agrees to provide the District, within sixty calendar days, a truthful and complete list of the names of all subcontractors, vendors, and suppliers that bidder has used in the past five years on any of its contracts that were undertaken within the District relevant geographic market as defined in Palm Beach County School Board Policy 6.143, including the total dollar amount paid by bidder for each subcontract or supply contract. Awarded bidder agrees to fully cooperate in any investigation conducted by the District pursuant to this Policy. Bidder understands and agrees that violation of this clause is a material breach of the Contract and may result in contract termination, debarment, and other sanctions.
7. **INDEMNIFICATION AND HOLD HARMLESS:** Contractor shall, in addition to any other obligation to indemnify the School Board and to the fullest extent permitted by law, protect, defend, indemnify, and hold harmless the School Board, its agents, officers, elected officials, and employees from and

against all claims, actions, liabilities, losses (including economic losses), or costs arising out of any actual:

- A. bodily injury, sickness, disease or death, or injury to or destruction of tangible property, including the loss of use resulting therefrom, or any other damage or loss arising out of, or claimed to have resulted in whole or in part from any actual act or omission of the Contractor, subcontractor, anyone directly or indirectly employed by any of them, or anyone for whose acts any of them may be liable in the performance of the work; or
- B. violation of law, statute, ordinance, governmental administration order, rule or regulation by Contractor in the performance of the work; or
- C. liens, claims or actions made by the Contractor or any subcontractor or other party performing the work; or
- D. claims by third parties (including, but not limited to, Contractor's employees or subcontractors) based upon an alleged breach by Contractor of any agreement with such third party (e.g., an employment agreement or licensing agreement), or allegation that Contractor's provision of services to the School Board pursuant to the Contract infringes upon or misappropriates a patent, copyright, trademark, trade secret, or other proprietary right of the third party.

The indemnification obligations hereunder shall not be limited to any limitation on the amount, type of damages, compensation, or benefits payable by or for the Contractor of any subcontractor under workers' compensation acts, disability benefit acts, other employee benefit acts, or any statutory bar. Such indemnification shall cease at such time the contract would not be renewed.

School Board acknowledges the waiver of sovereign immunity for liability in tort contained in Section 768.28, Florida Statutes, and acknowledges that such statute permits actions at law to recover damages in tort for monetary damages up to the limits set forth in such statute for death, personal injury or damage caused by the negligent or wrongful acts or omissions of a School Board employee acting within the scope of the employee's office or employment. The School Board agrees to be responsible for all such claims and damages, to the extent and limits provided in Section 768.28, Florida Statutes, arising from the actions of their respective employees. Each party acknowledges and it is expressly understood that the foregoing shall not constitute: (i) an agreement by the School Board to indemnify the School; (ii) a waiver of sovereign immunity by the School Board; (iii) a waiver of any right or defense that the School Board has under Section 768.28, Florida Statute, or any other statute; nor (iv) as consent to be sued by third parties.

Awarded bidder recognizes the broad nature of this indemnification and hold harmless article, and voluntarily makes this covenant for good and valuable consideration provided by the School Board in support of this indemnification in accordance with the laws of the State of Florida. This article will survive the termination of this Contract.

8. **BRAND NAMES:** Use of a brand name, trade name, make, model, manufacturer, or vendor catalog number in specifications is for the purpose of establishing a grade or quality of material only. It is not the District's intent to rule out other competition, therefore, the phrase OR ACCEPTABLE EQUAL is added. However, if a product other than that specified is bid, it is the vendor's responsibility to submit with the bid brochures, samples and/or detailed specifications on items bid. The District shall be the sole judge concerning the merits of bid submitted.

Bidder shall indicate on the bid form the manufacturer's name and number if bidding other than the specified brands, and shall indicate ANY deviation from the specifications as listed. Other than specified items offered requires complete descriptive technical literature marked to indicate detail(s) conformance with specific COPYRIGHTS OR PATENT RIGHTS: Bidder warrants that there has been no violation of copyrights or patent rights in manufacturing, producing or selling the goods shipped or ordered as a result of this bid. Seller agrees to hold the purchaser harmless from any and all liability, loss or expense occasioned by any such violation.

9. **MANUFACTURER'S CERTIFICATION:** The District reserves the right to request from bidders separate manufacturer certification of all statements made in the response to Invitation to Bid.

10. **OCCUPATIONAL HEALTH AND SAFETY:** Bidder, as a result of award of the bid, delivering any toxic substances item as defined in Code of Federal Regulation Chapter 29, shall furnish to the Purchasing Department, a Material Safety Data Sheet (MSDS). The material safety data sheet shall be provided with initial shipment and shall be revised on a timely basis as appropriate.

The MSDS must include the following information:

- A. The chemical name and the common name of the toxic substance.
- B. The hazards or other risks in the use of the toxic substance, including:
  - (1) The potential for fire, explosion, corrosively and reactivity;
  - (2) The known acute and chronic health effects of risks from exposure, including the medical conditions which are generally recognized as being aggravated by exposure to the toxic substance; and
  - (3) The primary routes of entry and symptoms of overexposure.
- C. The proper precautions, handling practices, necessary personal protective equipment, and other safety precautions in the use of or exposure to the toxic substances including appropriate emergency treatment in case of overexposure.
- D. The emergency procedure for spills, fire, disposal and first aid.
- E. A description in lay terms of the known specific potential health risks posed by the toxic substance intended to alert any person reading this information.
- F. The year and month, if available, that the information was compiled and the name, address and emergency telephone number of the manufacturer responsible for preparing the information.

Any questions regarding this requirement should be directed to: Department of Labor and Employment Security, Bureau of Industrial Safety and Health, Toxic Waste Information Center, 2551 Executive Center Circle West, Tallahassee, FL 32301-5014, Telephone 1-800-367-4378.

11. **OSHA:** The bidder warrants that the product/services supplied to the School District of Palm Beach County shall conform in all respects to the standards set forth in the Occupational Safety and Health Act 1970, as amended, and the failure to comply with this condition will be considered as a breach of contract.
12. **PRICES QUOTED:** Deduct trade discounts and quote firm net prices. Give both unit price and extend total. Prices must be stated in units of quantity specified in bid specifications. In case of discrepancy in computing the amount of the bid, the UNIT PRICE quoted will govern. All prices FOB destination, freight prepaid (unless otherwise stated in special conditions). Discounts for prompt payment: Award, if made, will be in accordance with terms and conditions stated herein. Each item must be bid separately and no attempt is to be made to tie any item or items in with any other item or items. Cash or quantity discounts offered will not be a consideration in determination of award of bid(s). If a bidder offers a discount, it is understood that a minimum of 30 days will be required for payment, and the discount time will be computed from the date of satisfactory delivery at place of acceptance and receipt of correct invoice at the office specified.
13. **CONDITIONS AND PACKAGING:** It is understood and agreed that any item offered or shipped as a result of this bid shall be new (current production model at the time of the bid). All containers shall be suitable for storage or shipment, and all prices shall include standard commercial packaging.
14. **UNDERWRITERS' LABORATORIES:** Unless otherwise stipulated in the bid, all manufactured items and fabricated assemblies shall be UL listed or re-examination testing where such has been established by UL for the items offered and furnished.
15. **DELIVERY:** Unless actual date of delivery is specified, show number of days required to make delivery after receipt of purchase order in space provided. Delivery time may become a basis for making an award (See Special Conditions). Delivery shall be within the normal working hours of the user, Monday through Friday, excluding holidays unless otherwise specified on the purchase order.
16. **QUALITY:** The items bid must be new and equal to or exceed specifications. The manufacturer's standard guarantee shall apply. During the guarantee period the successful bidder must repair and/or replace the unit without cost to the District with the understanding that all replacements shall

carry the same guarantee as the original equipment. The successful bidder shall make any such repairs and/or replacements immediately upon receiving notice from the District.

17. **SAMPLES, DEMONSTRATIONS AND TESTING:**

- A. Samples of items, when required, must be furnished free of expense and if not destroyed, will upon request, be returned at the bidder's expense. Request for the return of the samples must be indicated on his or her bid. Each individual sample must be labeled with bidder's name, bid number and item number. Failure of bidder to either deliver required samples or to clearly identify samples as indicated may be reason for rejection of the bid. Unless otherwise indicated, samples should be delivered to the Purchasing Department, School District of Palm Beach County.
- B. When required, the District may request full demonstrations of any units bid prior to the award of any contract.
- C. Items may be tested for compliance with specifications under the direction of the Florida Department of Agriculture and Consumer Services, or an independent testing laboratory. Bidders shall assume full responsibility for payment for any and all charges for testing and analysis of any materials offered or delivered that do not conform to the minimum required specifications. Bidder's disposition of all items delivered in this category must be at no expense to the District.

18. **INSPECTION AND ACCEPTANCE OF GOODS:** The awarded bidder shall be responsible for delivery of items in good condition at point destination. Bidder shall file with the carrier all claims for breakage, imperfections, and other losses, which will be deducted from invoices. The District will note, for the benefit of successful bidder, when packages are not received in good condition. In the event the material and/or services supplied to the District is found to be defective or does not conform to specifications, the District reserves the right to cancel the order upon written notice to the seller and return the product **to seller at the seller's expense.**

19. **LIABILITY, INSURANCE, LICENSES, AND PERMITS:** Where bidders are required to enter or go onto District property to deliver materials or perform work or services as a result of bid award, the bidder will assume the full duty obligation and expense of obtaining all necessary licenses, permits and insurance. Bidder shall be liable for any damage or loss to the District incurred by bidder, bidder's employees, licensees of the bidder or agent or any person the bidder has designated in completion of his or her contract as a result of the bid; further bidder shall be liable for all activities of bidder occasioned by performance of the Contract. Notwithstanding the foregoing, the liability herein shall be limited to ten million dollars (\$10,000,000) and the bidder recognizes that and covenants that it has received consideration for indemnification provided herein.

20. **SPECIFICATIONS:** Any omissions of detail specifications stated herein that would render the materials/service from use as specified will not relieve the bidder from responsibility.

21. **BID BONDS AND PERFORMANCE BONDS:** Bid bonds, when required, shall be submitted with the bid in the amount specified in Special Conditions. Bid bonds will be returned to unsuccessful bidders. After award of contract, the District will notify the successful bidder to submit a performance bond in the amount specified in Special Conditions. Upon receipt of the performance bond, the bid bond will be returned to the successful bidder.

22. **QUANTITIES:** The quantities shown are estimates of the quantity of items expected to be purchased during the term of award. Actual quantities purchased may often exceed or be less than quantities shown. Orders will be placed as needed by individual locations during the contract period. The bidder agrees that the price(s) offered shall be maintained irrespective of the quantity actually purchased.

23. **ORDERING PROCEDURE:**

Specific Items: After approval of Contract award by the Board, a letter of contract acceptance will be issued to each successful bidder acknowledging which goods or services have been awarded. Separate purchase orders will be issued based on specific items at firm, fixed prices listed in the bid.

Percent Discount Catalog Bids: Separate purchase orders will be issued with pricing based on catalog and/or price lists.

**No item may be shipped or service performed that is not listed on the purchase order.**

24. **POSTING OF BID AND SPECIFICATIONS:** Invitation to Bid with specifications will be posted for review by interested parties at Demandstar.com and at the Fulton Holland Educational Services Center, Purchasing Department, 3300 Forest Hill Boulevard, Third Floor, A-Wing Suite A-323, West Palm Beach, FL 33406, on the date of bid electronic mailing and will remain posted for a period of 72 hours. Failure to file a specification protest within the time prescribed in section 120.57(3), Florida Statutes, will constitute a waiver of proceedings under Chapter 120, Florida Statutes, and applicable Board rules, regulations and policies.
25. **BID PROTEST:** If a bidder wishes to protest a bid, they must do so in strict accordance with the procedures outlined in section 120.57(3), Florida Statutes, the Invitation to Bid, and School Board Policy 6.14.

Any person who files an action protesting bid specifications, a decision or intended decision pertaining to this bid pursuant to section 120.57(3)(b), Florida Statutes shall post with the Purchasing Department, at the time of filing the formal written protest, a bond secured by an acceptable surety company in Florida payable to The School Board of Palm Beach County, Florida in an amount equal to one percent (1%) of the total estimated contract value, but not less than \$500.00 nor more than \$5,000.00. Bond shall be conditioned upon the payment of all costs that may be adjudged against the protester in the administrative hearing in which the action is brought and in any subsequent appellate court proceeding. In lieu of a bond, a cashier's check, certified bank check, bank certified company check or money order will be acceptable form of security. If, after completion of the administrative hearing process and any appellate court proceedings, the District prevails, it shall recover all costs and charges included in the final order of judgment, including charges by the Division of Administrative Hearings. Upon payment of such costs and charges by the protester, the protest security shall be returned.

26. **TIE BID:** According to FS 287.087, tie bid preference shall be awarded to vendors with Drug Free Work Place programs. Whenever two or more are equal with regard to price, quality, and service, a bid received from a business that certifies that it has implemented a Drug Free Work Place program shall be given preference in the award process. In the event both vendors have a Drug Free Work Place preference shall be awarded to the vendor who is certified in the following order: as a M/WBE certified with the School District, as a SBE certified with the School District. If both vendors meet all three requirements, according to standard purchasing practice, the Director or Manager of Purchasing will flip a coin to break the tie. Vendor's company name closest to the letter "A" will always be assigned heads in the coin toss.
27. **INTERPRETATIONS:** Neither Demandstar nor any employee of the District is authorized to interpret any portion of the Invitation to Bid or give information as to the requirements of the bid in addition to that contained in the written bid document. Interpretations of the bid or additional information as to its requirements, where necessary, shall be communicated to bidders by written addendum.
28. **SPECIAL CONDITIONS:** If any conflict exists between any of the Special Conditions and/or the Specifications and either the General Conditions for Bids or the Instructions to Bidders, the Special Conditions and/or Specifications shall govern.

## 15C-32B - SPECIFICATIONS

### 1) General:

The purpose for this bid is to establish a pool of qualified vendors for the purchase and installation of playground equipment, playground surfacing, fabric shade structures, outdoor fitness equipment and fitness trails

- This bid is specifically for the purchase and installation of:
  - Playground equipment
  - Playground surfacing – including PIP and Artificial Turf
  - Outdoor fitness equipment
  - Fabric shade structures
  - Fitness trails which includes fitness stations and surfacing
- If awarded vendors sell other products, they may not be purchased referencing this bid (this includes benches, picnic tables, trash receptacles, etc.)
- Only vendors awarded under this bid will be allowed to participate in any upcoming projects for playgrounds, surfacing, repairs, fabric shade structures, outdoor fitness equipment and fitness trails
- If bidding to supply equipment, you must also either successfully bid on the installation of equipment and surfacing, site preparation and to supply ADA surfacing (meeting guidelines) **or** list your certified installer, who must submit a bid **and** be awarded a contract to supply/install all of these items
  - Bids not meeting this requirement will be rejected**
- The School District of Palm Beach County currently has 106 elementary schools, 33 middle schools & 23 high schools
  - Elementary schools have a minimum of two playgrounds, there are pre-school playgrounds at several high schools and schools with Head Start programs and several middle schools have outdoor fitness areas
- Bid awarded vendors will be given opportunities to submit proposals for all projects covered under this bid, including playgrounds for both existing school sites and new schools, as funding becomes available
- All products must be new, unused, of the latest design and technology and from the most current product lines.
- All installations shall be in compliance with District master Specifications where applicable

### 2) Warranty:

Bidders should include the following warranty compliance documents with their bid (upload and submit electronically through DemandStar) or provide to the purchasing agent within 24 hours of request:

- Applicable warranty and/or guarantees of equipment, surfacing and installations including any conditions and response time for repair and/or replacement of any components during the warranty period
- Availability of replacement parts
- Life expectancy of equipment and surfacing under normal use

At a minimum, the following warranties shall apply:

- A minimum of 5 years warranty shall be in effect for all equipment, installations, PIP surfacing, concrete curbing and sidewalks
- Artificial Turf shall have a minimum of 7 years warranty
- Recapping poured in place surfacing shall be warranted for a minimum of 3 years
- Sealer over poured in place surfacing shall be warranted for a minimum of 1 year
- Damage due to vandalism is exempt from warranty

### **3) Catalogs for Playground Equipment and Outdoor Fitness Equipment:**

Firm Percentage Discount: (see Item 1 on Bid Summary document)

- Bidder shall indicate in the space provided on the Bid Summary Document a single firm fixed percentage discount for each manufacturer's product line
- The District will accept a discount of 0%
- Bidders must bid a single fixed percentage discount, ex. 12% is acceptable, 11.075% isn't

Catalog and Price List:

- Awarded vendors for playground equipment and/or outdoor fitness equipment shall deliver their current catalog with prices or a price list if the catalog doesn't have prices to:  
School District of Palm Beach County  
Purchasing Department, Attn: Karen L. Adducci  
3300 Forest Hill Boulevard, Suite A-323  
West Palm Beach, FL 33406

Catalog Updates/Annual Replacements:

- The discounts, terms and conditions of this bid are to remain firm throughout the contract period
- During the contract period, the vendor may issue replacement catalogs
- The catalog replacements are to be delivered to the Purchasing Agent no less than 21 days prior to the effective date of same, along with a written request for acceptance and stating the effective date of such changes
- Prices may not be increased except when a new catalog with prices has been issued and accepted by the Purchasing Agent

### **4) Balance of Line:**

- The "balance of line" shall include new manufacturer's product line, new products, additional services and upgraded catalogs or products under the general category of items awarded under this bid
- Additions shall be submitted as they occur
- If awarded vendor is an authorized representative for a manufacturer and that relationship ends during the contract, written notice from the bid awarded company must be presented to the Purchasing Agent with a request for them to be allowed to provide a different manufacturer's product line for the duration of the contract
- If this occurs, it is the manufacturer's responsibility to find another bid awarded vendor to sell and install their product line for the duration of the contract and to receive approval from the Purchasing Agent

**5) Playground Equipment, Surfacing and Outdoor Fitness Equipment:**

- All equipment and surfacing provided must, at a minimum, meet the following standards: ADA (Americans with Disabilities Act) ASTM (The American Society for Testing and Materials), CPSC (Consumer Product Safety Council) and IPEMA (International Playground Equipment Manufacturers Association and all District standards
- Proposed playground packages must be approved and signed off by the District's certified playground safety inspector (CPSI) for compliance with national standards prior to a purchase order being issued.
- Regardless of how a project is funded, it must fully comply with all District standards and the current safety and ADA related requirements
- Any playground equipment or surfacing installed on Palm Beach County Schools' property not complying with safety regulations and all requirements in this bid shall be removed or replaced (at the sole discretion of the District) at no cost to the District

**5a) General Design Requirements:**

Playground and outdoor fitness equipment shall meet the following requirements:

- Equipment for Pre-K shall not exceed four feet in height
- Equipment for primary students shall not exceed six feet
- Equipment for intermediate students shall not exceed eight feet in height unless designed for uses other than climbing
- Outdoor fitness equipment shall be age appropriate
- Equipment shall be free of points, sharp edges and protrusions that may cut or puncture
- Equipment shall be free of protrusions and other elements that may snag clothing or body parts
- Equipment shall be free of angles or openings that may entrap body parts
- Equipment shall be free of pinch or crush points
- Equipment shall be free of splinters and not be subject to future splintering
- Equipment shall have slip resistant walking and climbing surfaces
- Equipment shall have components that drain freely and do not collect water
- Equipment shall have steps and handholds of proper size, spacing and incline where necessary to assist climbing
- Closed risers shall be placed at all steps
- Equipment shall have all moving parts constructed of materials that minimize the potential for impact injuries
- Equipment shall have handrails, raised edges and other barriers where necessary to minimize the potential for falls
- Equipment shall have vandal-proof connectors that cannot be loosened or unfastened without special tools
- Equipment shall permit easy access by adults for maintenance and emergencies
- Equipment shall provide more than one means of access and exit
- Equipment shall be designed to support the maximum possible load able to be imposed on the apparatus
- Equipment shall be designed to be permanently anchored in place
- Equipment shall be constructed of non-rusting and nontoxic materials and paints
- Equipment shall be constructed of materials that will remain durable in an outdoor environment
- All main (in-ground) support posts shall be powder coated aluminum

- Equipment shall not be constructed of wood or contain wooden components
- There shall be no tether balls or benches (or other seating) placed inside either the playground area or outdoor fitness equipment area
- If in the professional judgment of the District's Risk Management staff, a risk issue is raised regarding any equipment or surfacing, the final decision will be made by the District's Risk Management Certified Playground Safety Inspector (CPSI)
- A "Certificate of Completion" from the Building Department for permitted work is required
- No new playground package will be issued a final approval letter until the "Certificate of Completion" is received by Risk Management
- There shall be no walls, grates, drains, valves, or any other possible obstructions within a 6' perimeter of any playground unless protected by a 6' high (black vinyl) 9 Ga. fence, or one that matches existing chain link 6' high fences
- Access - All playgrounds shall be ADA compliant including having code compliant sidewalks to the ADA surfacing
- Equipment repairs, revisions or replacements by the vendor shall require prior approval from Risk Management

#### **5b) Curbs for Playgrounds:**

- **PIP surfacing:** Installer shall provide and install 4 inch wide x 12 inch deep new concrete curb at playground perimeter, with cut-outs for drainage. Installer shall submit a proposed curb detail for approval for monolithic slab installation
- **Artificial turf** - Installer shall provide and install 6 inch wide x 12 inch deep new concrete curb at playground perimeter, saw cut every 10 feet. Installer shall submit a proposed curb detail for approval for monolithic slab installation

**5c) Fencing:** (Fencing will **not** be purchased as part of this bid. It will be provided by the District's contracted vendor for fencing. This information is included because it is part of the playground requirements)

- All Pre-K, kindergarten and ESE (ADA) playgrounds will be surrounded with a 6' high, 9 gauge black vinyl double knuckle chain link fence, or one that matches existing chain link 6' high fences
- When the playground is located inside a school's existing 6' high perimeter fence, a 4' high fence may be allowed, at the District's discretion
- Fences surrounding K-2 playgrounds are required to have one gate equipped with panic hardware if under 2500 square feet and if over 2500 square feet two gates equipped with panic hardware are required
- Fencing shall comply with ASTM standard F2049-11

**5d) Standards:** Equipment manufacturers, vendors and installers shall adhere to the following safety standards:

American Society of Testing and Materials (ASTM)  
 ADA/ABA Accessibility Guidelines  
 Consumer Product Safety Commission (CPSC)  
 International Playground Equipment Manufacturers Association (IPEMA)  
 District standards where they exceed those guidelines  
 District Master Specifications - use this link  
<http://www.palmbeachschools.org/buildingdepartment/DMS2013pdf.asp> )  
 All state, federal and local safety rules and regulations

**5e) Signs:**

- Signage for all playgrounds shall be provided and installed in compliance with ASTM standards
- Signs may also be purchased for existing playgrounds

**5f) Replacement Parts:**

- Replacement parts, whether under warranty or not, must be available in the United States or the vendor must give the District an option of delivery by Priority shipping or overnight delivery, payable by the District
- Bidder shall indicate in space provided on the Bid Summary document all manufacturers' lines they are authorized to sell parts for and the firm percentage discount of list price
- Replacement parts shall be new
- Failure to deliver parts in a timely manner may result in bidder being considered non-compliant and removed from the list of bid awarded vendors eligible to do any business under this bid

**6) Installation of Surfacing and Equipment:**

If bidding equipment only and listing multiple installers (who are also awarded contracts), it will be the responsibility of the vendor providing the equipment to determine which certified installer will do each job; however, if the installers have bid different rates, the District will only be billed the lowest rate for the installation.

**6a) The installer shall comply with the following:**

- Each day an employee of the installer shall report to the school's main office, register in the appropriate sign-in book, list the number of employees on the school site and sign out at the end of the day
- Furnish, at own expense, all supervision, equipment, machines, tools, materials, labor, transportation, and anything necessary to perform site preparation, installation of equipment and surfacing
- The School District will provide water and electricity from the point of closest hook-up only (no hoses or electrical cables will be provided)
- The School District will be responsible for sprinkler relocation when necessary
- Contractors will consider the means of egress from any playground structure and be certain that no component presents an obstruction
- Private locates shall be the responsibility of the installing contractor in order to verify all interfering private or public owned utility locates (the cost shall be billed to the District)
- Ultimately, the Installer shall be held responsible for utility repairs required as a result of construction damages
- Erect and maintain a barrier around the entire playground until it has passed inspection by the District's CPSI and been released for use
- Protect all school buildings, structures, and utilities that are underground, above ground, or on the surface from their operations which may be hazardous and/or damaging to school facilities
- Protect all personnel (school staff and installer's employees), and students or others on school campuses against hazards and/or injuries that might result from installer's work
- This shall include, but not be limited to, the erection of barricades and signs to isolate the work site and minimize the risk of injury to anyone on the school campus

- Safeguard all tools, materials, and equipment at all times, including after work hours
- Provide security for the site while surfacing is curing, drying, etc. (there shall be no cost to the District for this security)
- Not prohibit entrance or exiting from school fire lanes, doorways, gates, etc.
- Verify and be responsible for the accuracy of all field measurements
- Ensure that all work is installed straight, level, plumb and in a professional manner
- Have frequent pick-up of all rubbish, refuse, scrap materials, and debris
- Remove all rubbish, scrap, etc., from the school site
- No rubbish shall be used as fill on the school site and installer may not use the school's dumpster
- Leave the work site in a neat and orderly manner at the end of each work day
- At completion of the installation, the site shall be in a ready to use condition, free of any debris
- Repair or replace, according to local codes and School District's satisfaction, all water lines, sanitary lines, electrical lines, curbs, sidewalks, streets, parking lots, fences, grassed areas, etc., broken or damaged as a result of the installer's operations
- Restore the site to its original condition, which may include re-sodding the area affected by their work with sod of the same variety and quality as the surrounding sod
- Where no sod exists prior to installation, the installer shall restore grade to a level consistent with the surrounding grade, and provide and install sod, if requested by the District (this sod is billable)
- All finish grading and final cleanup shall be the responsibility of the vendor
- Provide a maintenance manual and repair kit for all installed playground structures/equipment, delivered to the District Maintenance Plant & Operations (MP&O), 3300 Summit Blvd, West Palm Beach, FL., clearly labeled as to the school site it is for (there shall be no cost to the District)

**6b) Installation crew:**

- Supervisor shall be CPSI certified, be on site at all times, be fluent in English, be thoroughly knowledgeable of all plans, specifications and other contract documents and have the authority to act on the installer's behalf
- For each awarded project, vendor will provide:
  - Supervisor's name and certification
  - A list of the crew
  - Confirmation that all crew has completed the District background check and has a District issued badge in compliance with the Jessica Lunsford Act
- Installation crew must be factory certified to install equipment and surfacing
- All of the installer's employees and subcontractors shall wear School District badges and fully comply with the Jessica Lunsford Act
- Comply with School Board Policies and Rules prohibiting smoking and consumption of alcohol and illegal drugs while anywhere on District property.
- All of the installer's employees shall be clean and appropriately dressed at all times, whether school is in session or not. Shirts shall be worn at all times.
- Installation crew shall only use restroom facilities as determined at the pre-construction meeting
- At no time shall anyone use student restroom facilities, including when school is not in session.

**6c) Sanitary Facilities**

- The Contractor shall provide sanitary temporary toilet buildings for the use of all workers
- All toilets shall comply with local codes and ordinances
- Toilets shall be kept supplied with toilet paper and shall have workable door fasteners
- Toilets shall be serviced no less than once weekly and shall be present in a quantity of not less than 1 per 20 workers or as otherwise required by OSHA regulation
- The toilets shall be maintained in a sanitary condition at all times

**6d) The Jessica Lunsford Act:**

- All awarded bidders who are permitted access on school grounds when students are present, who may have direct contact with any student of the District, or who may have access to or control of school funds must be fingerprinted and background checked
- Awarded bidder agrees to undergo a background check and fingerprinting if he/she is an individual who meets any of the above conditions and to require that all individuals in the organization who meet any of the conditions to submit to a Level 2 FDLE background check and FBI screening, including fingerprinting by the School District's Police Department, at the sole cost of Awarded bidder
- The report of the results will be immediately transmitted to the School District's Police Department, which shall be the sole determiner of clearance
- Awarded bidder shall not begin providing services contemplated by the Invitation to Bid until Awarded bidder receives notice of clearance by the School District and is issued School District badges
- Compliance requiring all awarded bidders to register as a visitor before entering school property and proper display of School District badges will be strictly enforced
- Neither the Board, nor its members, officers, employees, or agents, shall be liable under any legal theory for any kind of claim whatsoever for the rejection of awarded bidder (or discontinuation of awarded bidder's services) on the basis of these compliance obligations
- Awarded bidder agrees that neither the awarded bidder, nor any employee, agent or representative of the awarded bidder who has been convicted or who is currently under investigation for a crime delineated in section 435.04, Florida Statutes, will be employed in the performance of the contract
- In addition, all awarded vendor's representative who attend mandatory site visits in order to bid on a project are required to have complied with the Jessica Lunsford Act and wear their District issued badges at all meetings

**6e) Dumpsters:**

- Dumpsters and all job site trash are the responsibility of the installer
- The District representative will provide a list of recommended dumpster companies by area
- Dumpsters must be located so as not to interfere with traffic at the school site and shall be promptly removed upon completion of job
- The installer shall clean or make any necessary corrections to any area damaged by a dumpster

**7) Surfacing:** (See Items 3 & 4 on Bid Summary Document)

- Surfacing for all playgrounds shall be poured in place with the exception of some Pre-K playgrounds where the District may approve artificial turf
- Surfacing must be IPEMA certified and a copy of the certification shall be provided with each awarded proposal package
- There will be no loose fill type surfacing and no tiles
- Provide & install clean fill as needed, compacted to 2,500 PSF (compaction test to be provided by vendor) to ensure positive drainage away from playground
- Poured In Place Surfacing shall meet current ASTM standards for impact attenuation and maneuverability
- A mandatory 4 inch wide x 12 inch deep concrete perimeter curb is required for poured in place surfacing and a 6" wide X 12" deep concrete perimeter curb is required for all synthetic turf applications
- All playground and fitness trail surfacing material being bid must be approved by the District's Risk Management staff
- Product specifications, (M)SDS and samples if requested, must be provided within twenty-four hours of request

**7a) Random Testing of Surfacing:**

- A sampling of the surface material that is installed may be tested to be certain its quality and consistency matches that which was ordered
- In order to verify that the proper amount of binder is being used; a random sample will be collected by District staff and tested at an independent lab
- If it fails, the vendor agrees to provide a seal coating in 2 years or increase the length of the warranty and will reimburse the District for the testing
- If a vendor's sample fails more than twice, the District may cancel the contract without penalty. This will not relieve the vendor from warranty obligations

**7b) Surfacing – Repair, Recap and/or Replace** (See Item 15 on Bid Summary)

- Projects to repair, seal, patch, recap, and or replace surfacing will be posted on DemandStar as an RFQ and a mandatory site visit will be scheduled with bid awarded vendors
- Only awarded vendors for Item 15 on the Bid Summary will be eligible to participate in these projects
- All RFQ responses must be uploaded to DemandStar by the date and time specified for each project
- The EPDM layer will be 5/8"
- Pre and Post drop test will be performed by the District's Risk Management Certified Playground Safety Inspector (CPSI) when surfacing repairs encompass the entire area to ensure it conforms to ASTM F-1292 requirements
- Complete tear-outs of surfacing will not require a pre-test
- All materials must be IPEMA certified and documentation will be required
- Materials and installations shall comply with all current applicable codes and standards
- Vendor shall ensure the entire surface is cleaned upon completion of repairs or any work
- Upon award and receipt of a purchase order, work must be scheduled and completed in a timely manner and to the satisfaction of the District
- There will be no charge for consultation or troubleshooting on any project

**7c) Artificial turf – where fall protection is Not required:** (See Item 5 on Bid Summary Document)

- Projects will be posted on DemandStar and a mandatory site visit will be scheduled with bid awarded vendors
- Artificial turf shall comply with the current and any updated District Master Specifications
- All turf seams will be secured with Velcro **and** adhesive and the turf will be secured firmly so that it cannot be lifted in any manner
- Install per manufacturer's specifications and ensure proper drainage
- A mandatory 6" wide X 12" deep concrete perimeter curb will be used for all synthetic turf applications

**8) Fabric Shade Structures** (See Item 16 & 17 on Bid Summary)

- When funding is available during the term of this contract, projects for Fabric Shade Structures will be posted on DemandStar as an RFQ and a mandatory site visit will be scheduled with bid awarded vendors
- Only awarded vendors for this product (Item 16 & 17) on the Bid Summary will be eligible to participate in these projects
- All RFQ responses must be uploaded to DemandStar by the date and time specified for each project
- There will be no charge for consultation or troubleshooting on any project
- All quotes must provide cost for labor, materials and installation
- All free-standing shade structures must be approved by the District Building Department
- Permits and inspection are required
- Signed/sealed engineered drawings showing the structural supports/foundations meet 150 mph wind loads are required
- Engineered drawings must be prepared by a State of Florida Registered engineer
- The fee for providing engineered drawings, signed and sealed by a State of Florida registered engineer shall be stated on the Bid Summary document
- Shade structures shall be certified by a US Testing Laboratory, comply with Florida Building Code, meet wind load and comply with District Master Specs (a copy is included in this bid)
- Fabric cover shall meet the requirements of NFPA 701, Standard Methods of Fire Tests for Flame Resistant Textiles and Film. A certificate or label sewn into fabric showing compliance must be provided for each project
- Provide instruction on care of the fabric and any requirements for re-treating the fabric to maintain its fire retardant classification
- This bid does not include covered walkways, aluminum awnings or shade structures other than fabric

**9) Fitness Trails** (See Items 18 & 19 on Bid Summary Document)

- When funding is available during the term of this contract, projects for Fitness Trails will be posted on DemandStar as an RFQ and a mandatory site visit will be scheduled with bid awarded vendors
- Only awarded vendors for Items 18 & 19 on the Bid Summary will be eligible to participate in these projects
- All RFQ responses must be uploaded to DemandStar by the date and time specified for each project
- There will be no charge for consultation or troubleshooting on any project
- All quotes must provide cost for labor, materials and installation
- Fitness trail equipment shall be appropriate for the age level at the site or school
- Fitness trail equipment shall include introductory signs, station signs, exercise stations, heartbeat check guides and all components in compliance with ASTM, CPSC or ADA laws
- Signs shall not be made of wood or contain wood components
- The awarded vendor shall be responsible for ensuring any and all fitness trail surfacing, fall zones, fall protection, pathways and equipment for Palm Beach County Schools meet the safety requirements as stated in this bid document including any updates by the District, ASTM, CPSC or ADA laws regardless of how the project is funded
- Proposed Fitness Trail packages must be approved and signed off by the District's certified playground safety inspector (CPSI) and the District's Building Department if required, prior to an order being placed
- Fitness trail stations shall meet the same requirements as playground equipment and outdoor fitness equipment
- Fitness trails may have different types of ADA surfacing if approved by the District's certified playground safety inspector (CPSI)
- Bidders should submit surfacing spec sheets, test data, etc. with bid or within 24 hours of request by the purchasing agent, for review and approval of any surfacing bid for fitness trails
- The District reserves the right to utilize other bids for the purchase and installation of the fitness trail surfacing if it is deemed to be in the best interest of the District

**10) Proposals:**

- The District's Playground and Outdoor Fitness Equipment Proposal form will be used for all proposals to provide & install playgrounds and outdoor fitness equipment and surfacing
- All successful bidders will make copies of this form as needed at no cost to the District
- When a project has been awarded, the awarded vendor will prepare 5 sets of packages containing all of the following for review by the District's Risk Management Certified Playground Safety inspector (CPSI):
  - 1) Playground Proposal form
  - 2) A list of components and the price for each as listed in their catalog/price list
  - 3) 3-Dimensional drawing
    - With a 180 degree view showing the type and color of surfacing
    - State the grade level on the drawing, under the school's name
    - Show the fall/use zone measurements, height of equipment, and ADA access route
    - List the number and name of the playground components meeting ADA requirements for lower and upper level components
  - 4) 2-Dimensional drawing;
    - Shall be on 11" X 17" paper with NO font being less than 1/8"
    - List the number and name of the playground components meeting ADA requirements for lower and upper level components
    - Identify "North" on the drawing
    - Include a scale on the drawing
    - State the grade level on the drawing, under the school's name
    - An identifying symbol shall be added to indicate that a curb will surround the playgrounds (4" for poured in place)
  - 5) Architectural Site Plan (to be provided by the District facilitator) clearly indicating the location of the playground(s) or fitness trails, the ADA compliant access route and the geographical orientation
  - 6) (M)SDS forms and IPEMA (The International Playground Equipment Manufacturers Association) certification for the surfacing
  - 7) A letter of compliance from the manufacturer describing their compliance with 16 CFR Part 1303 and Section 3 Federal Hazardous Substances Act with regard to lead, and Section 8 of the Consumer Product Safety Act with regard to phthalates

**11) Process:**

- Project is identified, funded and a requisition is processed
- Request For Quotes (RFQ) is prepared and posted on DemandStar by the purchasing agent
- RFQ is only open to bid awarded vendors. Note: A vendor may be removed from the list of eligible vendors at the sole discretion of the District purchasing agent for a period of time which may include the remainder of the contract. This would prevent the vendor from participating in any project and their name will be removed from the list of Bid Awarded Vendors.
- Mandatory site visit scheduled - vendor representatives will view the site, take measurements and be given project specifications
- Any project specific questions will be addressed and published through DemandStar as an addendum
- If tree trimming or removal is required, vendor may be requested to provide a quote
- Vendors prepare a proposal and upload it to DemandStar by the due date and time
- Projects for shade structures and surfacing repairs or replacements will be awarded to the lowest bidder or as stated in the RFQ
- For new or replacement playgrounds
  - All qualified proposals are reviewed and short-listed to top 3 best meeting the needs of the school
  - The three selected will make oral presentations to school based staff
  - The staff will rank the proposers as first, second and third
  - Selection may be based on innovation of design, number of components/activities, aesthetic, play value of the equipment, etc.
  - Award tabulation will be posted on DemandStar
  - Awarded vendor will prepare five (5) packages and deliver them to the District's facility representative for review to ensure they are complete
  - District's Facility representative will deliver the packages to the Risk Management department for review and signed approval by a District CPSI
  - Within seven (7) days, the CPSI shall approve or request additional information or changes
  - If the equipment changes or anything requested affects the cost of the project, the vendor will submit five (5) revised Playground Proposal forms and five (5) sets of any other documents or drawings that have been revised
  - Approved and sign-off packages go to purchasing agent who issues a PO which is notice to begin project
- For all projects, District's facility representative will schedule pre-construction meeting with awarded vendor, installation supervisor and school representative
  - The meeting will address:
    - Schedule for deliveries and installation
    - Site access
    - Dumpster requirements
    - Sanitary facilities
    - Permitting if required
    - Vendor will provide supervisor and crew documentation (per requirements listed above)
    - Any other pertinent information

- District's facility representative shall periodically check installation process and verify that all workers on site are fully complying with all District policies, are badged and comply with the Jessica Lunsford Act
- District's facility representative verifies the job is complete
- Where required, a District CPSI will inspect the equipment and surfacing for safety and ADA compliance
- Any other issues such as quality will be addressed by the purchasing agent and the District's facility representative
- Payment will be made for both materials and installation only after successful inspection by the District's CPSI, completion of a Professional Performance Evaluation –PPE (Vendor evaluation) and receipt of Certificate of Completion
- No deposits or partial payments will be made
- New school construction (including replacement school construction)  
The above process will be followed except after award of the project, the installer shall coordinate all deliveries and work with the Construction Manager
- If the District makes any changes to the above procedures during the contract, all awarded vendors will be notified by the Purchasing Agent and shall fully comply with any revisions.

### **12) Post Bid Award Meeting**

- After award of this contract, all awarded vendors will attend a mandatory start-up meeting at the District (exact location, date & time to be determined)
- District staff involved in these types of projects will be available to review basic District guidelines and requirements
- All awarded vendors are required to have a representative attend in order to participate in projects available through this bid

### **13) Glossary of Terms**

ADA	Americans with Disabilities Act
ASTM	American Society for Testing Materials
CM	Construction Manager
CPSC	Consumer Product Safety Commission
CPSI	Certified Playground Safety Inspector
IPEMA	International Playground Equipment Manufacturers Association
MSDS	Material Safety Data Sheets
NPSI	National Playground Safety Inspector
PPE	Professional Performance Evaluation

The School District of Palm Beach County  
Project Name  
SDPBC Project No.

SECTION 13 31 00  
PLAYGROUND SHADE STRUCTURES

PART 1 GENERAL

1.1 RELATED DOCUMENTS

- A. Drawings and general provisions of the Contract, including General and Supplementary Conditions and Division 1 specification sections, apply to work in this section.

1.2 SUMMARY

- A. The shade structure contractor shall be responsible for design, engineering, fabrication, and supply of the work specified herein.
- B. The intent of this specification is to have only one manufacturer responsible for all the functions.

1.3 REFERENCES

- A. ASCE 7 – Minimum Design Loads for Buildings and other Structures
- B. ASTM A135/A135M – Standard Specification for Electric Resistance Welded Steel Pipe
- C. ASTM A500/A500M – Standard Specification for Cold Formed Welded and Seamless Carbon Steel Structural Tubing in Rounds and Shapes
- D. ASTM E84 – Standard Test Method for Surface Burning Characteristics of Building Materials
- E. NFPA 701- Standard Methods of Fire Tests for Flame Propagation of Textiles and Films
- F. FBC - Florida Building Code
- G. FFPC Florida Fire Prevention Code

1.4 SUBMITTALS

- A. Provide installed reference sites with structures for similar scope and installation engineered to the FBC requirements.
  - 1. Provide minimum of 5-references in Southeast Florida, preferably 5-years or more in age.
  - 2. Include in reference list of structure dimensions with install dates and project locations.
- B. Provide material samples and color available.
- C. Provide signed and sealed engineered drawings and structural calculations prepared by Florida licensed Engineer.
- D. Provide certification the fabric meet NFPA 701 requirements.

1.5 WARRANTY

- A. The successful bidder shall provide a one-year warranty on all labor and materials.
- B. Provide a supplemental non-prorated 10-year warranty from the manufacturer on fabric including stitching and 20-years on the structural integrity of the steel, from date of substantial completion.
- C. The warranty shall not deprive the Owner of other rights under the provisions of the Contract Documents, are in addition to, and run concurrent with, other warranties made by the Contractor under requirements.

PART 2 PRODUCTS

The School District of Palm Beach County

Project Name

SDPBC Project No.

## 2.1 GENERAL

- A. Design and manufacture the shade product to the most exacting specifications by skilled craftsmen, and certified by Professional Engineers for structural soundness of designs.
- B. Ship all shade products knocked-down, with complete assembly instructions, and ready for easy in-field installation
- C. Engineer the structures to meet or exceed the requirements of the FBC.
- D. Design to the following wind speeds:
  - 1. Frame only           Wind load of area installed per current wind map for Risk Category I
  - 2. Frame w/canopy    90 M.P.H.
- E. Material:
  - 1. All materials shall be structurally sound and appropriate for safe use.
  - 2. Ensure product durability by the use of corrosion-resistant metals such as stainless steel, and coatings such as zinc plating, galvanizing, and powder coating on steel parts, subject to the product-specific requirements.
  - 3. Use fabrics with UV-stabilizers and fire retardants for longevity and safety.
- F. Packaging: Wrap all metal posts, rafters, and beams to protect the powder coat finish during shipping.
- G. Weldments: Factory weld all tubing members using Certified Welders meeting American Welding Society (AWS) specifications and to the highest standards of quality workmanship.
  - 1. Finish the weldments with a zinc-rich galvanized coating.
  - 2. Minimize or omit field welding in the assembly of the shade products.
- H. Posts, Structural Frame Tubing, and Hardware:
  - 1. Use cold-formed and milled tubing meeting ASTM A135/A135M and ASTM A500/A500M requirements.
  - 2. Test material in accordance with ASTM E8.
  - 3. Minimum yield is 40,000 psi, minimum tensile strength of 45,000 psi on all posts.
  - 4. Pre-cut all tubing to appropriate lengths, and galvanize all outside surfaces with an exterior corrosion-resistant zinc-rich coating.
  - 5. Where required, schedule-40 support pipes of hot-dip galvanized or powder-coated black steel.
  - 6. All fastening hardware shall be stainless steel.
- I. Powder-coating Process:
  - 1. Completely clean and properly, pre-treat all powder-coated parts before coating.
  - 2. Apply powder coating electrostatically and oven-cured at 375 to 425 degrees Fahrenheit.
  - 3. Powders shall meet or exceed ASTM standards for Adhesion, Hardness, Impact, Flexibility, Overbake Resistance, and Salt Spray Resistance.
  - 4. Owner shall select color from manufacturer's palette.
- J. Design the footings per the FBC for the specified structure.
- K. Roofing:
  - 1. Design structural frames use with shade fabric.
  - 2. Attach the fabric to frame using a vinyl covered minimum diameter galvanized and clear vinyl coated cable.
  - 3. Provide zinc-plated copper cable fasteners for maximum corrosion resistance.

## 2.2 FASTENING SYSTEM

- A. Deliver the Shade Fabric complete with independent cables pre-inserted in fabric hems.
- B. Loop and clamp each cable at each end.

The School District of Palm Beach County

Project Name

SDPBC Project No.

- C. Provide a Fastening System with a factory-installed device at each roof rafter corner.
- D. The fastening device should feature a concealed mechanism.
- E. Attach cables to a hook welded to the moving sleeve, thereby distributing tension evenly over rafters and not directly onto the mechanism.
- F. Seal the rafters with no penetrations on the top side, thereby preventing water from entering.
- G. Provide a locking cap at the end of each rafter with a vandal-resistant bolt (special wrench provided by the manufacturer) to prevent unauthorized access to the fastening device mechanism.
- H. Provide a system to adjust the tension on the fabric, which staff controls with the proper tool supplied by the vendor.
- I. Provide instructional video DVD on handling the shade structure, exact procedure for removing, and re-attaching canopy using an actual shade structure in the field.

### 2.3 FABRIC

#### A. Shade Fabric:

- 1. Knitted of monofilament and tape construction high-density polyethylene with Ultra Violet (U.V.) stabilizers and flame retardant, UV-Block Factor varies by standard color offered from 91% to 99%.
- 2. Normal Thickness: 0.057 inches
- 3. Fabric Mass: Min 337 g/m<sup>2</sup>
- 4. Light Fastness: 7-8 (Blue Wool Scale)
- 5. Weather Fastness: 4-5 (Grey Scale Test)
- 6. Tear Resistance: Warp 210N Weft 276N
- 7. Breaking Force: Warp 786N Weft 1544N
- 8. Bursting Pressure: Mean 3125kPa
- 9. Bursting Force: Mean 1775N
- 10. All hems and seams are double rowlock stitched using exterior grade UV-stabilized polyethylene sewing thread.

#### B. Flammability:

- 1. Treat shade fabric with fire retardants that pass the requirements established under the NFPA 701 Test Method 2 test standards for flammability, including the accelerated water leaching protocol.
- 2. Furnish written evidence of compliance with this standard, including with accelerated water leaching protocol, with bid proposal.

## PART 3 EXECUTION

### 3.1 INSTALLATION

- A. Installations of shade structure(s) by an installer who shall comply with the manufacturer's instructions for assembly, installation, and erection, per approved drawings.
- B. The site shall be free of construction debris upon the completion of the project.

END OF SECTION

The School District of Palm Beach County

Project Name:

SDPBC Project No.:

SECTION 32 18 16.13  
ARTIFICIAL TURF PLAYGROUND PROTECTIVE SURFACING

PART 1 GENERAL

1.1 SECTION INCLUDES

- A. Requirements for installation of a protective surfacing system at play areas equipped with play equipment, the protective surfacing system shall include:
1. Synthetic turf top surface
  2. Synthetic granular material or granular rubber material in a layer below the synthetic turf, or a closed cell polyurethane foam layer below the synthetic turf.
  3. Geotextile layer between the granular material or closed cell foam and the rock layer.
  4. Properly placed rock layer below the synthetic granular material
  5. Geotextile layer between the rock layer and the sub-grade.
  6. Properly prepared soil sub-grade under the rock layer
  7. Concrete containment curb around the system
  8. Synthetic nailing strip around the interior of the curbing
  9. Provisions for removal of storm water from the system and transmission of same to the on-site storm water management system.

1.2 REGULATORY REQUIREMENTS

- A. The protective surfacing system shall provide:
1. Fall protection as required by Federal and State Statutes, Standards, Regulations, and reference materials noted herein.
  2. Accessibility as required by Federal and State Statutes, Standards, and Regulations.
  3. An integral suppression from harmful biological growth including bacterium, molds, fungi, viruses, and any other pathogenic organism.
    - a. Integral shall mean that substances are directly incorporated into the manufacture of the various system components for the purpose identified herein, as opposed to substances applied to the finished system after construction.
    - b. Integral shall alternately mean that the substance naturally resists harmful biological growth in its native, as-manufactured state.

1.3 REFERENCE DOCUMENTS

- A. Guide to ADA Accessibility: Guidelines for Play Areas (May 2001)
- B. Florida Building Code Section 423, State Requirements for Educational Facilities
- C. Florida Building Code -Accessibility
- D. ASTM F1487 - Standard Consumer Safety Performance Specification for Playground Equipment for Public Use
  1. Compliance with this standard must be third party certified by the International Play Equipment Manufacturer's Association (IPEMA)
- E. ASTM F1292 - Standard Specification for Impact Attenuation of Surface Material Within the Use Zone of Playground Equipment
  1. Compliance with this standard must be third party certified by the International Play Equipment Manufacturer's Association (IPEMA)

The School District of Palm Beach County

Project Name:

SDPBC Project No.:

- F. District Master Specifications: Section 03 30 00, Cast-in-Place Concrete and Section 33 40 00, Storm Drainage Utilities

#### 1.4 SUBMITTALS

- A. The Contractor shall furnish to the District the manufacturers' literature and data for all materials installed under this section for approval by the District prior to purchasing or installation.
  - 1. Standard submittals shall include but not be limited to:
    - a. A list of playground equipment components with catalog prices
    - b. 3-dimensional playground layout drawing
    - c. 2-dimensional playground layout drawing
  - 2. This submittal shall also include a scaled site plan that shows the limits of the protective surface system installation, the placement of play equipment within the protective surface limits, and a 12-foot wide clear area around the limits of the protective surface system.
    - a. Verify the 12-foot clear limits through site inspection and use of original Facility as built or construction documents.
  - 3. Submittals shall also include a product mock-up that shows a complete cross-section of the proposed artificial turf section, from the turf through the fall protection layer and drain rock.
    - a. The mock-up will be provided in a clear plastic container that measures 12 inches square, minimum.
    - b. The mock-up will include examples of all seams within construction materials, including the artificial turf, geotextile, and fall protection layers.

#### 1.5 RELATED DOCUMENTS

- A. General provisions of the purchase Contract as provided by others in the District.

#### 1.6 WARRANTY

- A. The system components and installation shall have a minimum one-year warranty covering 100% of all manufacturers' or installation defects.
  - 1. The Contractor providing installation shall immediately repair all defects and separately address any issues with the various component manufacturers. Uninterrupted use of the facilities is critical for proper District operations.
- B. Other individual component warranties, as required of the manufacturer, listed in Part 2.

#### 1.7 LEED COMPLIANCE

- A. The District has determined that projects shall be constructed complying with Leadership in Energy and Environmental Design (LEED) requirements as promulgated in the document titled: LEED Reference Guide for Green Building Design and Construction, For the Design, Construction and Major Renovations of Commercial and Institutional Buildings, Including Core & Shell and K-12 School Projects, 2009 Edition.
- B. The District goal is LEED Silver Certification for all major projects. Certification is not required for small projects consisting only of playground construction.
- C. At a minimum, investigate the potential LEED compliance areas as listed below for construction in accordance with this specification.
  - 1. MR Credit 4 – Recycled Content

The School District of Palm Beach County

Project Name:

SDPBC Project No.:

## 2. MR Credit 5 – Regional Materials

### PART 2 PRODUCTS

#### 2.1 General

- A. Product ASTM standard compliance must be third party certified by the International Play Equipment Manufacturer's Association (IPEMA).
- B. Rock or natural granular mineral materials shall be obtained from virgin sources and not be from recycled construction materials. All rock or natural granular materials shall be free of metallic or sharp edged glass-like materials.
- C. All manufactured materials shall be completely free of lead or lead compounds.

#### 2.2 SYNTHETIC TURF

- A. The synthetic turf shall be Endura Ultra RSIFLTK2-PB or equal. The required properties are:
  - 1. Pile weight – 43 oz. / sq. yd
  - 2. Face yarn type – Polyethylene monofilament with textured nylon mono thatch layer
  - 3. Yarn count – Primary, 5000/4; Secondary, 4200/8
  - 4. Pile height (tufted) – 1-3/4 inch (pre-finished)
  - 5. Color – Verde
  - 6. Construction – Broadloom tufted, dual yarn, same row
  - 7. Tufting gauge – 3/8 inch
  - 8. Primary backing – 6.0 oz/sq yd polypropylene, polyester, and fiber backing
  - 9. Secondary backing – 50 oz/sq yd urethane
  - 10. Tertiary backing – 3.5 oz/sq yd geotextile fleece
  - 11. Total product weight – 103 oz/sq yd plus/minus 2 oz/sq yd
  - 12. Finished roll width – 15 feet
  - 13. Finished roll length – up to 240 feet
  - 14. Anti-microbial yard – 50% by weight
- B. The turf shall be rated by independent testing from a nationally certified testing agency as complying with a minimum drop height of 12-feet in accordance with ASTM F1292.
- C. The turf shall be rated by an independent testing from a nationally certified testing agency as complying with accessibility in accordance with ASTM F1951.

#### 2.3 SYNTHETIC GRANULAR MATERIAL / RUBBER GRANULAR MATERIAL

- A. The synthetic granular material or rubber granular material shall be GTR SOFT-COVER or a similar product manufactured specifically for playground applications.
  - 1. The granular product shall be completely steel-free and sized between 3/8 and 1/8 inch in size.
    - a. The granular product may be produced from used automobile tires.
  - 2. A six-inch thick layer of the granular product shall be rated by independent testing from a nationally certified testing agency as complying with a minimum drop height of 12 feet in accordance with ASTM F1292.

#### 2.4 CLOSED CELL POLYURETHANE FOAM PAD

The School District of Palm Beach County

Project Name:

SDPBC Project No.:

- A. The pad shall be Polygreen Foam Playground Pad as manufactured by United Sustainable Surfaces of America, or pre-approved equal.
  - 1. The pad made from 100% recycled, non-contaminated post-industrial cross-link closed-cell polyethylene foam.
  - 2. The proposed layer thickness of the foam product shall be rated by independent testing from a nationally certified testing agency (IPEMA) as complying with a minimum drop height of 12 feet in accordance with ASTM F 1292.

## 2.5 GEOTEXTILE

- A. Geotextile shall be Mirafi S600 nonwoven polypropylene material as manufactured by TenCate Geosynthetics North America, or a pre-approved equal. The required material properties are:
  - 1. Grab tensile strength (ASTM D4632) – 160 pounds (ultimate) at 50% elongation.
  - 2. Trapezoidal tear strength (ASTM D4533) – 65 pounds.
  - 3. CBR puncture strength (ASTM D6241) – 450 pounds.
  - 4. UV resistance after 500 hours (ASTM D4355) – 80% strength.
  - 5. Permittivity (ASTM D4491) – 1.5 sec<sup>-1</sup>
  - 6. Flow Rate (ASTM D4491) – 110 gal/min/sq ft

## 2.6 ROCK LAYER

- A. The rock layer shall be prepared using FDOT number 57 or number 4 stone.
  - 1. Minimum layer thickness shall be four inches.
  - 2. Rock layer shall be mechanically tamped to ensure minimal settlement and maintenance of uniform layer thickness and surface slope after construction.

## 2.7 COMPACTED SUBGRADE

- A. The compacted sub-grade density shall be at least 95% of T-99.
  - 1. The minimum layer thickness shall be six inches.

## 2.8 CONCRETE CURBING

- A. The concrete curbing shall be manufactured using a design mix that will produce a minimum 28-day compressive strength of 3,000 psi.

## 2.9 SYNTHETIC NAILING STRIP

- A. The synthetic nailing strip shall be manufactured from recycled plastic containers.
  - 1. Use Poly-tuf HDPE Dimensional Plastic Lumber or equivalent product.
    - a. Size shall be equal to dimensional 2x4 lumber.
  - 2. Allow spacing between sections of plastic lumber to account for the relatively large coefficient of thermal expansion.

## 2.10 FASTENERS

- A. All fasteners shall be manufactured using stainless steel or another material with similar corrosion and natural bacteriological resistance.
  - 1. Fasteners shall include nails, staples, bolts, screws, nuts, washers and other similar manufactured objects.

The School District of Palm Beach County

Project Name:

SDPBC Project No.:

- a. Tapcon self-tapping stainless steel concrete anchors or equivalent.
- b. Rapid or Arrow 304 stainless steel staples for fastening synthetic turf to nailer strip.

### PART 3 EXECUTION

#### 3.1 GENERAL

- A. Provide a fall protection assembly as generally shown in Exhibit 1, which appears at the end of this section.

#### 3.2 SEAMS

- A. All turf material seams, which are field fabricated between individual rolls of turf material, shall be made using Velcro and glue or a similar process that produces a full strength seam between rolls.
- B. All turf material seams around equipment supports shall be completely sealed to the support and have no open spaces or other defects that form an attractive nuisance for students to pull that seam apart beginning at the defect.
  1. All seams at equipment supports shall be uniform in appearance.
  2. Seams at supports shall comply with Exhibit 2, which appears at the end of this section.

#### 3.3 FASTENING

- A. Fasten synthetic wood nailing strip to concrete curbing using stainless steel self-tapping fasteners.
  1. Use fastener spacing as needed to meet anticipated working loads imparted from the synthetic turf. Confirm working loads with turf manufacturer or provide fastener spacing such that the turf will tear before the fasteners will pull from the concrete.
- B. Fasten synthetic turf to the synthetic wood nailing strip using stainless steel staples.
  1. Staple spacing as recommended by the turf manufacturer or calculated to exceed the turf strength as noted above.
  2. The turf edge treatment shall be as specified by the turf manufacturer.
- C. Fasteners shall be attached to concrete 14 or more days after the concrete has been placed.

#### 3.4 CONCRETE PLACEMENT

- A. Place concrete in accordance with DMS 03 30 00.
  1. Control joints will be placed at five foot intervals, maximum longitudinal spacing and will be saw cut, minimum 6 inch depth, joint shall be made within 24 to 60 hours after concrete placement.
  2. Place all expansion joints at one side of all corners and at 50 foot maximum longitudinal spacing.

#### 3.5 PLAY EQUIPMENT FOUNDATIONS

- A. Play equipment foundations shall be prepared and placed in accordance with the play equipment manufacturer's requirements.
  1. Where foundations require use of cast-in-place concrete, the concrete and reinforcing steel shall comply with the specifications provided herein.

The School District of Palm Beach County

Project Name:

SDPBC Project No.:

### 3.6 PERIODIC INSPECTION

- A. Periodic inspection of construction will be provided by the SDPBC at the following points:
  - 1. When formwork and reinforcing steel has been placed and assembly is ready to receive concrete.
  - 2. When subgrade has been compacted, play equipment foundations have been placed, and synthetic nailer has been attached to the concrete curbing.
- B. All inspection comments must be resolved and re-inspection may be required.

### 3.7 SITE RESTORATION

- A. The Work area shall be completely restored to the sole satisfaction of the District without additional payment to the Contractor.
  - 1. All construction equipment, materials, supplies, temporary supports and other appurtenant items shall be completely removed from the school site.
  - 2. All grassed areas and landscaping shall be restored to pre-construction conditions unless otherwise specified by the District.

### 3.8 FINAL INSPECTION

- A. A final inspection shall be performed by the District's Department of Risk Management. A Certified Playground Inspector (CPI) will observe the completed project.
  - 1. All final inspection comments shall be resolved to the sole satisfaction of the District CPI without additional compensation.
  - 2. The Contractor may, from time to time, request informal inspections by the CPI to verify that the general intent of the project documents is being met. CPI inspections shall not replace the required Building Department inspections.

*(NOTE – EXHIBIT 1 AND EXHIBIT 2 APPEAR ON THE FOLLOWING PAGES)*

The School District of Palm Beach County

Project Name:

SDPBC Project No.:

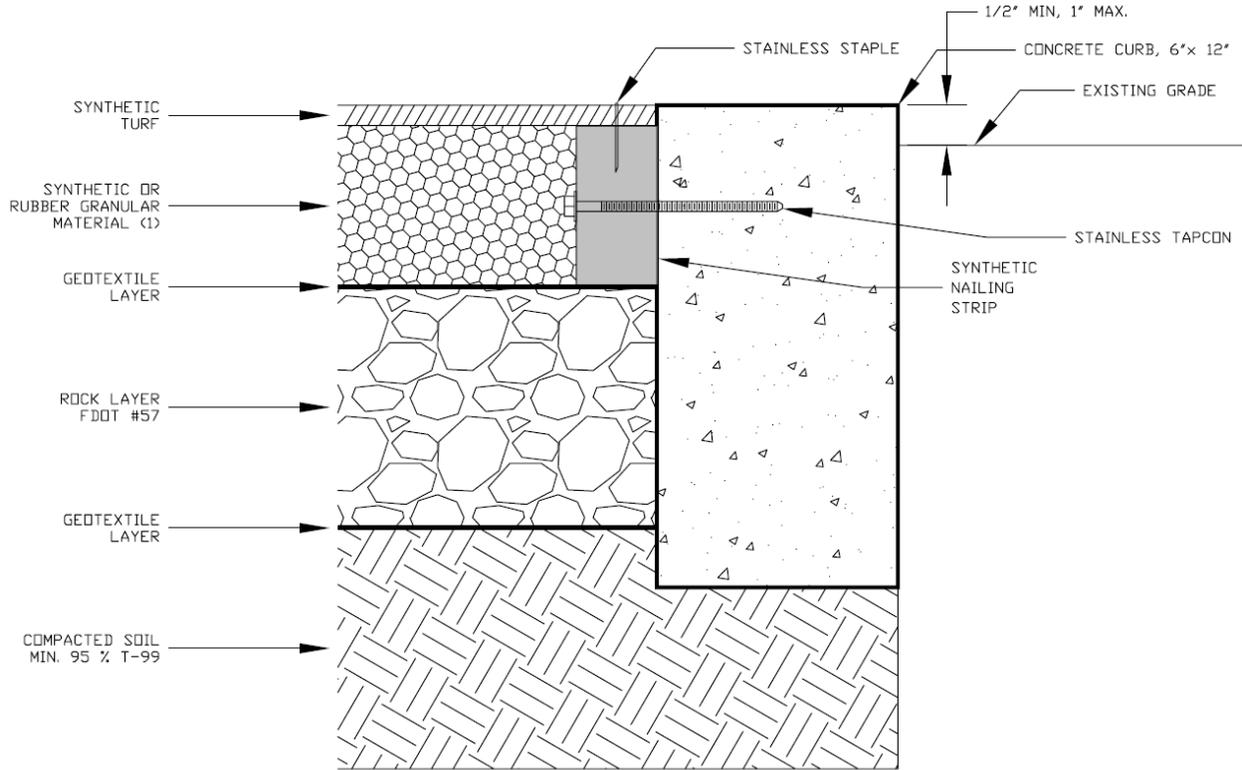

(1) CONTRACTOR MAY SUBSTITUTE MANUFACTURED PADDING MATERIAL PER SPECIFICATION PARAGRAPH 2.4

EXHIBIT 1

The School District of Palm Beach County

Project Name:

SDPBC Project No.:

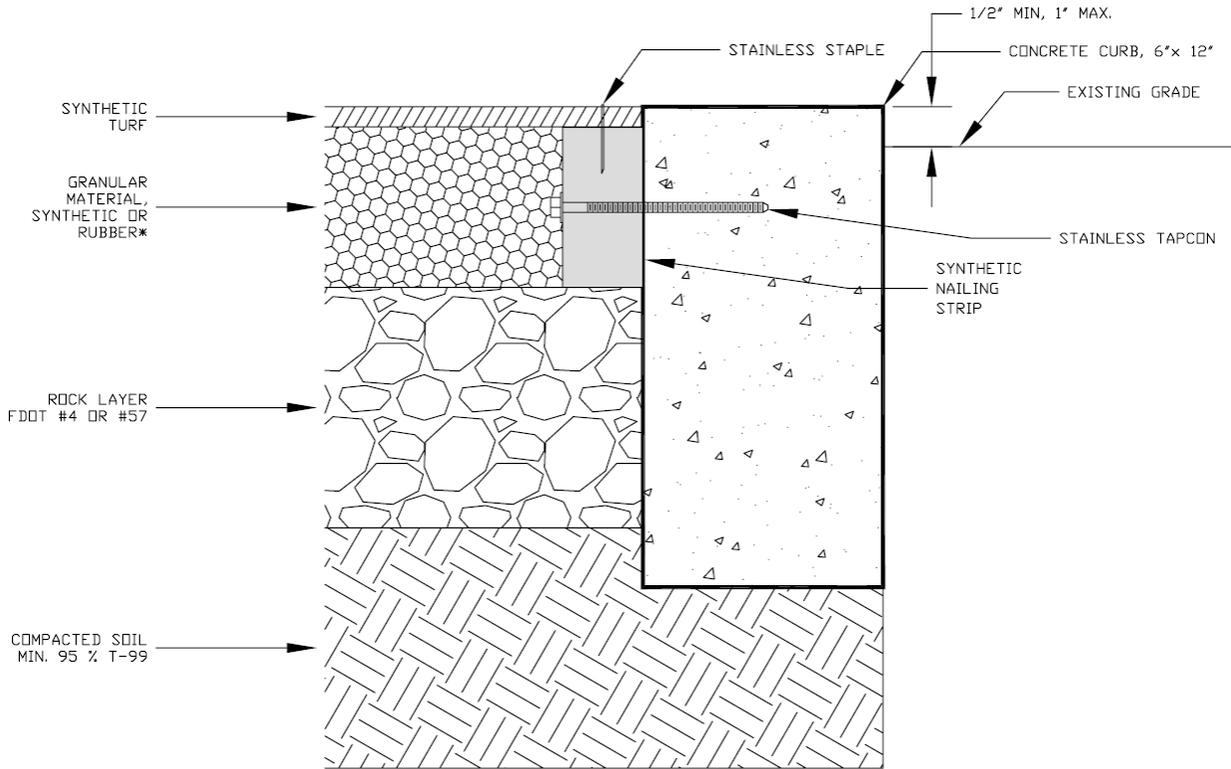

\* CONTRACTOR MAY SUBSTITUTE MANUFACTURED PADDING MATERIAL PER SPECIFICATION PARAGRAPH 2.2.B.

EXHIBIT 1

The School District of Palm Beach County

Project Name:

SDPBC Project No.:

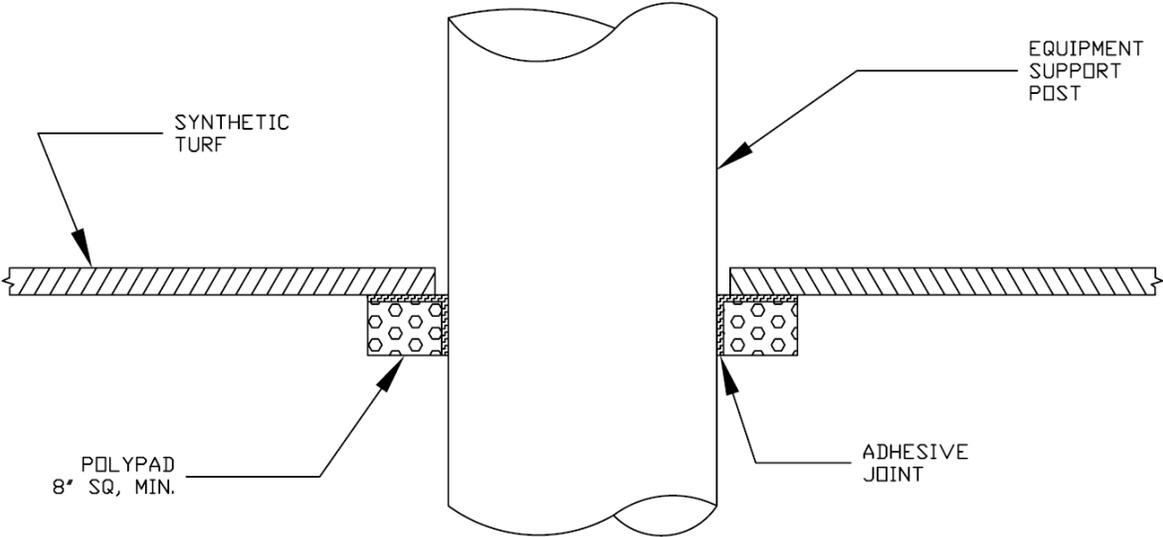

NOTES:

- 1. POLYPAD SHALL BE A POLYETHYLENE PAD BLENDED WITH SOME RECYCLED POLYOLEFIN MATERIAL, 1 INCH THICK. THE PAD MATERIAL SHALL HAVE A MINIMUM TEAR RESISTANCE OF 35 POUNDS PER INCH, DETERMINED IN ACCORDANCE WITH ASTM D3575. THE PAD SHALL BE COATED WITH A SUITABLE BINDER SO THE ADHESIVE WILL BOND THE PAD TO THE OTHER MATERIALS.
- 2. ADHESIVE SHALL BE LOCTITE PL 400.
- 3. EQUIVALENT MATERIALS MAY BE PROVIDED AND WILL BE SUBJECTED TO A FIELD PERFORMANCE TEST TO VERIFY EQUIVALENCY. MATERIALS THAT FAIL THE FIELD TEST WILL BE COMPLETELY REPLACED AT NO ADDITIONAL COST TO THE DISTRICT.

EXHIBIT 2

END OF SECTION

SCHOOL DISTRICT OF PALM BEACH COUNTY  
PURCHASING DEPARTMENT

May 20, 2015

ADDENDUM NO. 1

INVITATION TO BID NO. 15C – 32B

TITLE: TERM CONTRACT FOR PLAYGROUND EQUIPMENT, OUTDOOR FITNESS EQUIPMENT, SURFACING, FITNESS TRAILS AND FABRIC SHADE STRUCTURES

RETURN DATE: May 27, 2015 - 2:00 P.M. EST

This addendum modifies the above listed Invitation to Bid as follows:

Add to Read:

The Beneficial Interest and Disclosure of Ownership Affidavit was omitted from the original bid packet documents. This document has now been uploaded to Demandstar, please download this document and include in your bid packet submittal.

  
\_\_\_\_\_  
Morris Simpson, Purchasing Agent

  
\_\_\_\_\_  
Genell McMann, Purchasing Manager

Posting of Conditions/Specifications

This Addendum will be posted for review by interested parties, at DemandStar.com on the date of the Addendum electronic mailing and will remain posted for a period of 72 hours. Failure to file a protest on any changes to the specifications contained in the Addendum within the time prescribed in section 120.57 (3) Florida Statutes, will constitute a waiver of proceedings under Chapter 120 Florida Statutes, and applicable School Board rules, regulations and policies.

Any person who files an action protesting the specifications contained in this Addendum, pursuant to Section 120.57(3)(b), Florida Statutes shall post with the Purchasing Department, at the time of filing the formal written protest, a bond secured

by an acceptable surety company in Florida payable to the School Board of Palm Beach County in an amount equal to 1 percent (1%) of the total estimated contract value, but not less than \$500 nor more than \$5,000. Bond shall be conditioned upon the payment of all costs that may be adjudged against the protester in the administrative hearing in which the action is brought and in any subsequent appellate court proceeding. In lieu of a bond, a cashier's check, certified bank check, bank certified company check or money order will be acceptable form of security. If, after completion of the administrative hearing process and any appellate court proceedings, the Board prevails, it shall recover all costs and charges included in the final order of judgment, including charges by the Division of Administrative Hearings. Upon payment of such costs and charges by the protester, the protest security shall be returned.



THE SCHOOL DISTRICT OF PALM BEACH COUNTY  
**Beneficial Interest and Disclosure of Ownership Affidavit**

Bid No. 15C-32B Project No./ Title Playground Equipment, Outdoor Fitness Equipment, Surfacing, Fitness Trails, and Fabric Shade Structures

Corporate Name \_\_\_\_\_ Tax FEIN No. \_\_\_\_\_

Before me, the undersigned authority, personally appeared, \_\_\_\_\_, ("Corporate Representative") this \_\_\_\_\_ day of \_\_\_\_\_, 20 \_\_, who, first being duly sworn, as required by law, subject to the penalties prescribed for perjury, deposes and says:

- 1) Corporate Representative has read the contents of this Affidavit, has actual knowledge of the facts contained herein, and states that the facts contained herein are true, correct, and complete.
- 2) The following is a list of every "person" (as defined in Section 1.01(3), Florida Statutes to include individuals, children firms, associates, joint adventures, partnerships, estates, trusts, business trusts, syndicates, fiduciaries, corporations and all other groups and combinations) holding 5% or more of the beneficial interest in the disclosing entity: (If more space is needed, attach separate sheet)

A. Persons or corporate entities owning 5% or more:

Name	Address	Percentage

B. Persons or corporate entities who hold by proxy the voting power of 5% or more:

Name	Address	Percentage

C. Stock held for others and for whom held:

1. Name / 2. From Whom Held	Address	Percentage
1. _____		
2. _____		
1. _____		
2. _____		
1. _____		
2. _____		

CORPORATE REPRESENTATIVE

By: \_\_\_\_\_

**SWORN TO** and subscribed before me this \_\_\_\_\_ day of \_\_\_\_\_, 20 \_\_, by \_\_\_\_\_ Such person(s) (Notary Public must check applicable box).

is/are personally known to me.  produced a current driver license(s).  produced \_\_\_\_\_ as identification.

(NOTARY PUBLIC SEAL)

\_\_\_\_\_  
Notary Public

\_\_\_\_\_  
(Print, Type or Stamp Name of Notary Public)

**THE SCHOOL DISTRICT OF PALM BEACH COUNTY  
PURCHASING DEPARTMENT  
3300 Forest Hill Boulevard, Suite A-323  
West Palm Beach, FL 33406-5813**

**INVITATION TO BID  
15C-32B  
Bidder Acknowledgement**

**Vendor Name:**

**Vendor Mailing Address:**

**E-Mail Address:**

**Area Code / Telephone Number:**

**Toll-Free Telephone Number:**

**Fax Number:**

**Web Address:**

**FEID No. or SS #:**

**Delivery calendar days after receipt of order:**

**ANTI-COLLUSION**

By electronically submitting your bid, the bidder certifies that they have not divulged, discussed or compared their bid with other bidders and have not colluded with any other bidder or parties to a bid whatever. No premiums, rebates or gratuities permitted either with, prior to, or after any delivery of material. Any such violation will result in the cancellation and/or return of materials (as applicable) and the removal from the bid lists for the School District of Palm Beach County, Florida and I hereby certify that I have read and understand the requirements of this Invitation to Bid and that I am duly authorized to execute this offer document and any contract(s) and/or other transaction by award of this bid.

**BID CERTIFICATION**

I further certify that I have read the entire contents of this Invitation to Bid document and agree to full, complete and unconditional acceptance of the contents of this Invitation to Bid and all appendices and the contents of any Addendum released hereto. I further certify that by virtue of executing and returning this Bidder Acknowledgement Form, I am submitting the following information as this company's response.

**Name of Representative Submitting Bid :**

**Title of Company Representative:**

**Date:**

### 15C-32B – Bid Summary

<b>Item 1</b>	<b>Playground Equipment And Outdoor Fitness Equipment</b> <u>Firm Percentage Discount</u> <ul style="list-style-type: none"> <li>Will be deducted from the catalog list prices</li> <li>Bidders must bid a single fixed percentage discount, ex. 12% is acceptable; 11.075% is not</li> <li>The District will accept a discount of 0%.</li> </ul> <u>Freight Charges:</u> <ul style="list-style-type: none"> <li>All freight charges are to be prepaid by successful bidders and added to the invoice</li> <li>The School District will only pay actual freight charges</li> <li>It is further agreed by all vendors signing this bid proposal that title to all items ordered, remain with the vendor until received and accepted by the School District</li> <li>Vendor is required to file all claims for damages/shortages etc.</li> </ul>	
	<b>List the Playground Equipment Manufacturer(s) and the Outdoor Fitness Equipment Manufacturer(s) you represent</b>	<b>Fixed % Percentage Discount off List Price</b>
<b>Item 2.</b>	<b>Installation of Playground and Outdoor Fitness Equipment</b>	<b>Fixed Percentage</b>
	Cost will be based on a firm fixed percentage of the equipment cost (the total after discount has been taken but before freight has been added)	
<p><b>NOTE:</b>                  If bidding to only supply Playground and/or Outdoor Fitness Equipment,                  • you must list your certified installer below                      <b>AND</b>                  • Your certified installer must submit a bid for installation                      <b>AND</b>                  • Your certified installer must be awarded a contract for installation                  in order for you to be awarded to provide playground and/or outdoor fitness equipment</p>		
<b>Playground and Outdoor Fitness Equipment Installer's Company Name (if other than self):</b>		

<b>Item 3.</b>	<b>Poured In Place (PIP) Surfacing for Playgrounds and Outdoor Fitness Equipment</b>						
	<ul style="list-style-type: none"> <li>• Poured In Place (PIP) surfacing must be IPEMA Certified &amp; ADA compliant</li> <li>• Price must be stated per square foot and price must include all materials, adhesives or sub-bases</li> </ul>						
<b>List Manufacturer:</b>							
Critical Fall Height	3'	4'	5'	6'	7'	8'	10'
<b>3a)</b>							
Size	<b>Cost Per Sq Ft</b>	<b>Cost Per Sq Ft</b>	<b>Cost Per Sq Ft</b>	<b>Cost Per Sq Ft</b>	<b>Cost Per Sq Ft</b>	<b>Cost Per Sq Ft</b>	<b>Cost Per Sq Ft</b>
Up to 1,000 Sq Ft							
1,000 to 3,000 Sq Ft							
Over 3,000 Sq Ft							
<b>3b) Installation of PIP surfacing charge if it is not included in the prices above</b>						\$ _____ per Sq Ft	

<b>Item 4.</b>	<b>Artificial Turf installed on a playground (with fall protection)</b>						
	<ul style="list-style-type: none"> <li>• Must be IPEMA certified and ADA compliant</li> <li>• Price stated must be per square foot and price must include all materials, adhesives, etc.</li> </ul>						
<b>List Manufacturer:</b>							
Critical Fall Height	3'	4'	5'	6'	7'	8'	10'
<b>4a) Cost Per Sq Ft</b>							
Size	<b>Cost Per Sq Ft</b>	<b>Cost Per Sq Ft</b>	<b>Cost Per Sq Ft</b>	<b>Cost Per Sq Ft</b>	<b>Cost Per Sq Ft</b>	<b>Cost Per Sq Ft</b>	<b>Cost Per Sq Ft</b>
Up to 1,000 Sq Ft							
1,000 to 3,000 Sq Ft							
Over 3,000 Sq Ft							
<b>4b) Installation of Artificial Turf charge if it is not included in the prices above</b>						\$ _____ per Sq Ft	

<b>Item 5.</b>	<b>Artificial Turf – Provide and install where fall protection is NOT required</b>						
<b>List Manufacturer:</b>							
<b>5a)</b>	Cost Per Sq Ft	Cost Per Sq Ft	Cost Per Sq Ft	Cost Per Sq Ft	Cost Per Sq Ft	Cost Per Sq Ft	Cost Per Sq Ft
Size							
Up to 1,000 Sq Ft							
1,000 to 3,000 Sq Ft							
Over 3,000 Sq Ft							
<b>5b) Installation of Artificial Turf <u>Without</u> fall protection fee if installation is not included in the prices above</b>						\$ _____ per Sq Ft	

<b>Item 6.</b>	<b>Engineered Wood Fiber</b> Must comply with ASTM and be IPEMA certified Quotes will be requested when needed <b>Indicate if you can provide (Yes or No)</b>	___ Yes or ___ No
<b>List the Manufacturer:</b>		

<b><u>Site Preparation:</u></b>		
<ul style="list-style-type: none"> <li>All bidders for installation must complete this section in order to be awarded as the pool of pre-qualified vendors for all projects under this bid</li> <li>Provide firm prices for the following line items</li> <li>Prices must be submitted in the same unit of measure as listed below:</li> </ul>		
<b>Item 7.</b>	Dig-out/ Excavation Price must include removal and disposal	\$_____ per sq. ft.
<b>Item 8.</b>	Sand, clean & suitable for playgrounds Price must include delivery and placement	\$_____ per cubic yard
<b>Item 9.</b>	Clean Fill Delivered and graded	\$_____ per sq. ft.
<b>Item 10.</b>	Concrete – provide and install All concrete shall comply with DMS & FI. Building Code Includes concrete for sidewalks There shall be no additional fee for getting the concrete to the site	
<b>10a.</b>	4" Wide X 12" Deep for PIP surfacing	\$_____ per sq. ft.
<b>10b.</b>	6" Wide X 12" Deep for artificial turf	\$_____ per sq. ft.
<b>Item 11.</b>	Recycled playcurb borders Provide and install	\$_____ per linear ft.
<b>Item 12.</b>	Aluminum ADA handrails Provide and install	\$_____ per linear ft.
<b>Item 13.</b>	Provide Utility Locates	\$_____ each
<b>Item 14.</b>	Provide signed sealed engineered drawings	\$_____ per job

<b><u>Additional Site Preparation Items:</u></b>	
<p>Vendors may be required to provide quotations for optional items such as, but not limited to:</p> <ul style="list-style-type: none"> <li>removal and/or relocation of existing playground equipment</li> <li>replacement parts for playground components</li> <li>tree trimming or removal</li> <li>excavation/demucking for sites where rock or muck is found</li> <li>provide and lay sod in area surrounding playground where sand was (sod replacement for site restoration shall be done at no charge to the District)</li> </ul>	

<b>Item 15</b>	<p><b><u>Repair, Recap and/or Replace Playground Surfacing</u></b>                  Bidder wishes to be in the pool of pre-qualified vendors and be eligible to respond to Request For Quotes (RFQ) for projects to Repair, Recap and/or Replace Playground Surfacing</p> <p style="text-align: center;"><b>Mark an "X" in the space provided</b></p>	<p>___ YES</p>
----------------	---	----------------

<b>Item 16</b>	<p><b><u>Fabric Shade Structures :</u></b>                  This will establish a pool of pre-qualified vendors to furnish and install fabric shade structures as requested in accordance with the terms, specifications, District Master Specs and conditions set forth in this bid</p> <p><b><i>To be in the pool of pre-qualified vendors and be eligible to respond to Request For Quotes (RFQ) for Fabric Shade Structures, you must mark an "X" in the box by "YES"</i></b></p>	
----------------	---	--

NOTE:  
 If bidding to only supply Shade Structures

- you must list your certified installer below

**AND**

- Your certified installer must submit a bid for installation

**AND**

- Your certified installer must be awarded a contract to install this item in order for you to be awarded for this item

<b>Item 16</b>	<b><u>Provide Shade Structures</u></b>	___ YES	___ NO
----------------	--	---------	--------

<b>Manufacturer:</b>	
<b>Installer if other than self:</b>	

<b>Item 17.</b> <b><u>Install Shade Structure</u></b>	___ YES	___ NO
--	---------	--------

<p><b>Item 18. <u>Provide Fitness Trails (equipment/stations &amp; surfacing)</u></b></p> <p>This will establish a pool of pre-qualified vendors to furnish and install Fitness Trails as requested in accordance with the terms, specifications and conditions set forth in this bid and all applicable codes and standards.</p> <p><b><i>To be in the pool of pre-qualified vendors and be eligible to respond to Request For Quotes (RFQ) for Fitness Trails, you must mark an "X" in the box by "YES"</i></b></p>		
<p>NOTE: If bidding to only supply Fitness Trail Equipment/Stations,</p> <ul style="list-style-type: none"> <li>• you must list your certified installer below</li> </ul> <p style="text-align: center;"><b>AND</b></p> <ul style="list-style-type: none"> <li>• Your certified installer must submit a bid for installation</li> </ul> <p style="text-align: center;"><b>AND</b></p> <ul style="list-style-type: none"> <li>• Your certified installer must be awarded a contract for the installation in order for you to be awarded to provide Fitness Trail Equipment/Stations</li> </ul>		
<b>Item 18</b>	<b>Provide Fitness Trail Equipment</b>	<input type="checkbox"/> YES <input type="checkbox"/> NO
<b>Manufacturer:</b>		
<b>Installer if other than self:</b>		
<b>Item 19.</b>	<b><u>Install Fitness Trails and Surfacing</u></b>	<input type="checkbox"/> YES <input type="checkbox"/> NO

<b>Item 20. Replacement Parts for Playground or outdoor fitness equipment and supplies such as sealer for poured in place surfacing:</b> List the Playground Equipment Manufacturer(s) and the Outdoor Fitness Equipment Manufacturer(s) you are authorized to sell replacement parts or supplies for and provide a firm percentage discount to be taken off list price or mark "Yes" to provide quotes if you cannot give a single fixed discount off list price (Refer to Bid Specifications)	<b>Fixed Percentage Discount off List Price</b>	<b>Cannot give firm discount but will provide quotes when requested (Mark "Yes")</b>
Delivery Business Days After Receipt of Order (ARO):	_____ business days	
Address of facility where parts will be shipped from: _____		

<b>Item 21</b>	<b><u>Recoat existing PVC playground equipment decks</u></b> Provide on-site service to restore/renew decks that are worn and/or have coating that is peeling Includes cleaning, priming and recoating in compliance with all applicable standards and codes Bidder wishes to be in the pool of pre-qualified vendors and be eligible to respond to Request For Quotes (RFQ) for single jobs or larger projects to <b>Mark an "X" in the space provided</b>	____ YES
----------------	---	----------

<b>Vendor Name:</b>	
---------------------	--

**This form must be downloaded, completed and uploaded to DemandStar with your bid response**

**Bid 15C-32B**

**AREA REPRESENTATIVE**

Please list the contact for this bid

Vendor Name:	
Area Representative:	
Email Address:	
Cell Phone Number:	
Office Number (With extension)	

**This form must be downloaded, completed and uploaded to DemandStar with your bid response**

SCHOOL DISTRICT OF PALM BEACH COUNTY  
PURCHASING DEPARTMENT

DEBARMENT CERTIFICATION

CERTIFICATION REGARDING DEBARMENT, SUSPENSION,  
INELIGIBILITY AND VOLUNTARY EXCLUSION  
LOWER TIER COVERED TRANSACTIONS

This certification is required by the regulations implementing Executive Order 12549, Debarment and Suspension, 7 CFR Part 3017, Section 3017.510, Participants' responsibilities. The regulations were published as Part IV of the January 30, 1989, Federal Register (pages 4722-4733). Copies of the regulations may be obtained by contacting the Department of Agriculture agency with which this transaction originated. (Before Completing Certification, Read Instructions on Following Page)

- (1) The prospective lower tier participant certifies, by submission of this proposal, that neither it nor its principals is presently debarred, suspended, proposed for debarment, declared ineligible, or voluntarily excluded from participation in this transaction by an Federal department or agency.
- (2) Where the prospective lower tier participant is unable to certify to any of the statements in this certification, such prospective participants shall attach an explanation to this proposal.

Organization Name: \_\_\_\_\_

Solicitation Number or Project Name: Bid 15C-32B \_\_\_\_\_

Name of Authorized Representative: \_\_\_\_\_

Title of Representative: \_\_\_\_\_

Date: \_\_\_\_\_

**INSTRUCTION CERTIFICATIONS**

1. By electronic submission of this form the prospective lower tier participant is providing the certification set out on the reverse side in accordance with these instructions.
2. The certification in this clause is a material representation of fact upon reliance was placed when this transaction was entered into. If it is later determined that the prospective lower tier participant knowingly rendered an erroneous certification, in addition to other remedies available to the Federal Government, the department or agency with which this transaction originated may pursue available remedies, including suspension and/or debarment.
3. The prospective lower tier participant shall provide immediate written notice to the person to which this proposal is submitted if at any time the prospective lower tier participant learns that its certification was erroneous when submitted or has become erroneous by reason of changed circumstances.
4. The terms "covered transaction," "debarred," "suspended," "ineligible," "lower tier covered transaction," "participant," "person," "primary covered transaction," "principal," "proposal," "voluntarily excluded," as used in this clause, have the meanings set out in the Definitions and Coverage section so rules implementing Executive Order 12549. You may contact the person to which this proposal is submitted for assistance in obtaining a copy of those regulations.
5. The prospective lower tier participant agrees by submitting this form that, should the proposed covered transaction be entered into, it shall not knowingly enter into any lower tier covered transaction with a person who is debarred, suspended, declared ineligible, or voluntarily excluded from participation in this covered transaction, unless authorized by the department or agency with which this transaction originated.
6. The prospective lower tier participant further agrees by submitting this form that it will include this clause titled, "Certification Regarding Debarment, Suspension, Ineligibility and Voluntary Exclusion - Lower Tier Covered Transactions," without modification, in all lower tier covered transactions and in all solicitations for lower tier covered transactions.
7. A participant in a covered transaction may rely upon a certification of a prospective participant in a lower tier covered transaction that it is not debarred, suspended, ineligible, or voluntarily excluded from the covered transaction, unless it knows that the certification is erroneous. A participant may decide the method and frequency by which it determines the eligibility of its principals. Each participant may, but is not required to, check the Non-procurement List.
8. Nothing contained in the foregoing shall be construed to require establishment of a system of records in order to render in good faith the certification required by this clause. The knowledge and information of a participant is not required to exceed that which is normally possessed by a prudent person in the ordinary course of business dealings.
9. Except for transactions authorized under paragraph 5 of these instructions, if a participant in covered transaction knowingly enters into a lower tier covered transaction with a person who is suspended, debarred, ineligible, or voluntarily excluded from participation in this transaction, in addition to other remedies available to the Federal Government, the department or agency with which this transaction originated may pursue available remedies, including suspension and/or debarment.

SCHOOL DISTRICT OF PALM BEACH COUNTY  
PURCHASING DEPARTMENT

**EARLY PAYMENT TERMS**

<b>BID NAME/NUMBER:</b> _____ <b>VENDOR NAME:</b> _____
--

If vendor chooses not to participate in Early Payment Terms, please acknowledge by placing N/A here → \_\_\_\_\_.

<b>EARLY PAYMENT:</b> Specify terms and discount for early payment. Check which terms you will be willing to provide for the duration of this contract to the School District.
0.5% 10 net 30 *
0.75% 5 net 30 *

\* Upon receipt of invoice by the School District of Palm Beach County Accounts Payable Department.

**Note:** Updating to these terms will affect all of your District payments. If you choose to revise these terms at a later date, the terms will affect all of your payments from the District.

**PROPOSER'S STATEMENT OF PRINCIPAL PLACE OF BUSINESS**  
*(Must be completed & submitted with each competitive solicitation)*

Name of Proposer: \_\_\_\_\_

Identify the state in which the Proposer has its principal place of business: \_\_\_\_\_

Proceed as follow: **IF** your principal place of business above is located within the State of Florida, the Proposer may sign below and attach to your solicitation. No further action is required. **IF** your principal place of business is outside of the State of Florida the following must be completed by an attorney and returned with your solicitation. Failure to comply shall be considered to be non-responsive to this solicitation.

**OPINION OF OUT-OF-STATE BIDDER'S ATTORNEY ON BIDDING PREFERENCES**

*(To be completed by the Attorney for an Out-of-State Proposer)*

**NOTICE:** Section 287.084(2), Fla. Stat., provides that "a vendor whose principal place of business is outside this state must accompany any written bid, proposal, or reply documents with a written opinion of an attorney at law licensed to practice law in that foreign state, as to the preferences, if any or none, granted by the law of that state [or political subdivision thereof] to its own business entities whose principal places of business are in that foreign state in the letting of any or all public contracts." See also: Section 287.084(1), Fla. Stat.

**LEGAL OPINION ABOUT STATE BIDDING PREFERENCES**

*(Please Select One)*

\_\_\_\_\_ The Proposer's principal place of business is in the State of \_\_\_\_\_ and it is my legal opinion that the laws of that state **do not grant a preference** in the letting of any or all public contracts to business entities whose principal places of business are in that state.

\_\_\_\_\_ The Proposer's principal place of business is in the State of \_\_\_\_\_ and it is my legal opinion that the laws of that state **grant the following preference(s)** in the letting of any or all public contracts to business entities whose principal places of business are in that state: [Please describe applicable preference(s) and identify applicable state law(s)]:

\_\_\_\_\_  
\_\_\_\_\_  
\_\_\_\_\_

**LEGAL OPINION ABOUT POLITICAL SUBDIVISION BIDDING PREFERENCES**

*(Please Select One)*

\_\_\_\_\_ The Proposer's principal place of business is in the political subdivision of \_\_\_\_\_ and it is my legal opinion that the laws of that political subdivision **do not grant a preference** in the letting of any or all public contracts to business entities whose principal places of business are in that political subdivision.

\_\_\_\_\_ The Proposer's principal place of business is in the political subdivision of \_\_\_\_\_ and the laws of that political subdivision **grant the following preference(s)** in the letting of any or all public contracts to business entities whose principal places of business are in that political subdivision: [Please describe applicable preference(s) and identify applicable authority granting the preference(s)]:

\_\_\_\_\_  
\_\_\_\_\_  
\_\_\_\_\_

Signature of out-of-state Proposer's attorney: \_\_\_\_\_

Printed name of out-of-state Proposer's attorney: \_\_\_\_\_

Address of out-of-state bidder's attorney: \_\_\_\_\_

\_\_\_\_\_  
\_\_\_\_\_

Telephone Number of out-of-state bidder's attorney: (\_\_\_\_\_) \_\_\_\_\_ - \_\_\_\_\_

Email address of out-of-state bidder's attorney: \_\_\_\_\_

Attorney's states of bar admission: \_\_\_\_\_

Proposer's Printed Name: \_\_\_\_\_ Signature \_\_\_\_\_

Company Name: \_\_\_\_\_

SCHOOL DISTRICT OF PALM BEACH COUNTY  
PURCHASING DEPARTMENT

**Bid 15C-32B- REFERENCES**

**Vendor Name:** \_\_\_\_\_

This information will be used in the evaluation of this bid.

- Complete the information below
- Notify each reference that we will be contacting them by email and their response will be used in evaluating your company
- School District or Governmental agencies are preferred references
- References shall not be for work performed more than 3 years ago
- You may not list the School District of Palm Beach County as more than one reference

State the type of work you did for each reference from this list of options (list all that apply):

- Provided playground equipment**
- Installed playground or outdoor fitness equipment**
- Provided & installed PIP surfacing**
- Provided & installed artificial turf**
- Provided fabric shade structure**
- Installed fabric shade structure**
- Provided fitness trails**
- Installed fitness trails**

**Reference 1**

<b>School District, Governmental Agency or Company:</b>	
<b>Contact Person:</b>	
<b>Email:</b>	
<b>Phone #:</b>	
<b>Type of work (choose from list above)</b>	
<b>Date work was completed</b>	

**Reference 2**

<b>School District, Governmental Agency or Company:</b>	
<b>Contact Person:</b>	
<b>Email:</b>	
<b>Phone #:</b>	
<b>Type of work (choose from list above)</b>	
<b>Date work was completed</b>	

**Reference 3**

<b>School District, Governmental Agency or Company:</b>	
<b>Contact Person:</b>	
<b>Email:</b>	
<b>Phone #:</b>	
<b>Type of work (choose from list above)</b>	
<b>Date work was completed</b>	

**Reference 4**

<b>School District, Governmental Agency or Company:</b>	
<b>Contact Person:</b>	
<b>Email:</b>	
<b>Phone #:</b>	
<b>Type of work (choose from list above)</b>	
<b>Date work was completed</b>	

**Reference 5**

<b>School District, Governmental Agency or Company:</b>	
<b>Contact Person:</b>	
<b>Email:</b>	
<b>Phone #:</b>	
<b>Type of work (choose from list above)</b>	
<b>Date work was completed</b>	

**This form must be downloaded, completed and uploaded to DemandStar with your bid response**



**THE SCHOOL DISTRICT OF PALM BEACH COUNTY  
Drug-Free Workplace Certification**

Preference must be given to vendors submitting a certification with their bid/proposal certifying they have a drug-free workplace in accordance with Section 287.087, Florida Statutes. This requirement affects all public entities of the State and becomes effective January 1, 1991. The special condition is as follows:

**IDENTICAL TIE BIDS** - Preference shall be given to businesses with drug-free workplace programs. Whenever two or more bids which are equal with respect to price, quality, and service are received by the State or by any political subdivision for the procurement of commodities or contractual services, a bid received from a business that certifies that it has implemented a drug-free workplace program shall be given preference in the award process. Established procedures for processing tie bids will be followed if none of the tied vendors have a drug-free workplace program, a business shall:

- 1) Publish a statement notifying employees that the unlawful manufacture, distribution, dispensing, possession, or use of a controlled substance is prohibited in the workplace and specifying the actions that will be taken against employees for violations of such prohibition.
- 2) Inform employees about the dangers of drug abuse in the workplace, the business's policy of maintaining a drug-free workplace, any available drug counseling, rehabilitation, and employee assistance programs, and the penalties that may be imposed upon employees for drug abuse violations.
- 3) Give each employee engaged in providing the commodities or contractual services that are under bid a copy of the statement specified in subsection (1).
- 4) In the statement specified in subsection (1), notify the employees that, as a condition of working on the commodities or contractual services that are under bid, the employee will abide by the terms of the statement and will notify the employer of any conviction of, or plea of guilty or nolo contendere to, any violation of chapter 893 or of any controlled substance law of the United States or any state, for a violation occurring in the workplace no later than five (5) days after such conviction.
- 5) Impose a sanction on, or require the satisfactory participation in a drug abuse assistance or rehabilitation program if such is available in the employee's community, by any employee who is so convicted.
- 6) Make a good faith effort to continue to maintain a drug-free workplace through implementation of this section.

As the person authorized to sign the statement, I certify that this firm complies fully with the above requirements.

\_\_\_\_\_  
VENDOR'S SIGNATURE

\_\_\_\_\_  
DATE

\_\_\_\_\_  
COMPANYNAME

**Must be executed and returned with attached bid at time of bid opening to be considered.**

**School District of Palm Beach County**  
**MINORITY CERTIFICATION INFORMATION**

**Bid 15C-32B**

\* Check here if N/A: \_\_\_\_\_

Form **must be submitted** with your bid response to **Demandstar.com**

<p>Minority Certification applications are available through the Minority Business Enterprise located at:</p> <p style="padding-left: 40px;">Office of Diversity in Business Practices          School District of Palm Beach County          3300 Forest Hill Boulevard, Suite A-106          West Palm Beach, FL 33406-5871          Phone: (561) 434-8508  <a href="http://www.palmbeachschools.org/mwbe/">http://www.palmbeachschools.org/mwbe/</a></p>								
<p><b>Are you a minority vendor certified by:</b> (Check if appropriate)</p> <p style="padding-left: 40px;">Palm Beach County School District _____</p> <p style="padding-left: 40px;">State of Florida _____</p> <p>If yes, expiration date _____</p> <p>Minority Classification _____</p>								
<p>If you are not a certified minority vendor and intend to sub-contract with a certified minority firm(s), please list the vendors and the estimated dollar value below:</p> <table style="width: 100%; border-collapse: collapse;"> <thead> <tr> <th style="text-align: left; border-bottom: 1px solid black;"><u>Vendor</u></th> <th style="text-align: left; border-bottom: 1px solid black;"><u>Estimated Dollar Value</u></th> </tr> </thead> <tbody> <tr> <td style="border-bottom: 1px solid black;">_____</td> <td style="border-bottom: 1px solid black;">\$ _____</td> </tr> <tr> <td style="border-bottom: 1px solid black;">_____</td> <td style="border-bottom: 1px solid black;">\$ _____</td> </tr> <tr> <td style="border-bottom: 1px solid black;">_____</td> <td style="border-bottom: 1px solid black;">\$ _____</td> </tr> </tbody> </table>	<u>Vendor</u>	<u>Estimated Dollar Value</u>	_____	\$ _____	_____	\$ _____	_____	\$ _____
<u>Vendor</u>	<u>Estimated Dollar Value</u>							
_____	\$ _____							
_____	\$ _____							
_____	\$ _____							

Reminder: **Download all documents, complete them and save as a single PDF document and re-upload them to DemandStar.**

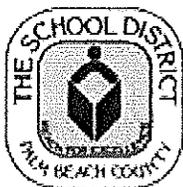

THE SCHOOL DISTRICT OF PALM BEACH COUNTY  
OFFICE OF DIVERSITY IN BUSINESS PRACTICES

# Participation Letter of Intent

Minority/Women Business Enterprise (M/WBE)     Small Business Enterprise (SBE)

Submit completed form to the Senior Project Administrator (SPA). Direct all questions to (561) 434-8508.  
**Form must be submitted to Demandstar.com**

BID/RFP or Project Name \_\_\_\_\_

BID/RFP or Project # \_\_\_\_\_

Name of Bidder/Construction Manager \_\_\_\_\_

The undersigned intends to perform work with the above project as (check one):

- Individual       Partnership       Corporation       Joint Venture\*

*\*If a joint venture, attach letterhead or other documentation proving relationship.*

The undersigned intends to perform work with the above project as (check one):

- Subcontractor       Subconsultant       Manufacturer       Supplier

The undersigned is:  Certified with the School District of Palm Beach County M/WBE Coordinator

Certified with the State of Florida, Department of General Services (Provisional)

The undersigned is: (MWBE must check one in column 1 and column 2; Column 2. completed by both MWBE or SBE; Column 3 completed by MWBE or SBE if applicable)

**Column 1 (MWBE ONLY)**

**Column 2 (MWBE ONLY)**

**Column 3**

- African American     Native American       Female       Physically Impaired  
 Asian American       American               Male  
 Hispanic American

**PARTICIPATION** The undersigned intends to perform the following work in connection with the above project:

Item No.	Division No.	Contract (Trade) Items (Description/Division)	Amount

If the undersigned intends to sub-contract any portion of this subcontract to a non-certified M/WBE or SBE subcontractor, the amount of any such subcontract must be stated \$ \_\_\_\_\_

Name of M/WBE or SBE Subcontracting Firm \_\_\_\_\_

Name and Position (type or print) \_\_\_\_\_

**INTERNAL USE ONLY - ROUTING DISPOSITION**  
All executed originals of the form must be submitted to the  
Office of Diversity in Business Practices  
3300 Forest Hill Blvd., A-106, West Palm Beach, FL 33406-5813

Signature \_\_\_\_\_

Date \_\_\_\_\_

HOOE DISTRICT OF PALM BEACH COUNTY  
**onsultant, Subcontractor &  
 for Participation Services**

1. PROJECT NAME \_\_\_\_\_ 2. PROJECT NUMBER \_\_\_\_\_ 3. PHASE (Precon, Demo, Const) \_\_\_\_\_ 4. TOTAL BID OR CM SERVI \_\_\_\_\_

**\* GMP SUMMARY AMOUNTS (Pre-construction phase fee + Construction phase fee + C**  
 Subject to Agreement with the Construction Manager, the Subcontractor firms (minority & i  
 below will participate in this project for the Contract (Trade) Items and the dollar amounts s

WBE  SBE  Check One:  Subconsultant  Subcontractor  Vendor

CONTRACTOR / SUBCONSULTANT / VENDOR NAME	BUDGET (Est. Cost)	CONTRACT AMOUNT	DESCRIPTION	MWBE or SBE (Yes or No)	AMOUNT
				<input type="radio"/> Yes <input type="radio"/> No	
				<input type="radio"/> Yes <input type="radio"/> No	
				<input type="radio"/> Yes <input type="radio"/> No	
				<input type="radio"/> Yes <input type="radio"/> No	
				<input type="radio"/> Yes <input type="radio"/> No	
				<input type="radio"/> Yes <input type="radio"/> No	
				<input type="radio"/> Yes <input type="radio"/> No	
				<input type="radio"/> Yes <input type="radio"/> No	
				<input type="radio"/> Yes <input type="radio"/> No	
				<input type="radio"/> Yes <input type="radio"/> No	
				<input type="radio"/> Yes <input type="radio"/> No	
				<input type="radio"/> Yes <input type="radio"/> No	
				<input type="radio"/> Yes <input type="radio"/> No	
				<input type="radio"/> Yes <input type="radio"/> No	
				<input type="radio"/> Yes <input type="radio"/> No	
				<input type="radio"/> Yes <input type="radio"/> No	
				<input type="radio"/> Yes <input type="radio"/> No	
				<input type="radio"/> Yes <input type="radio"/> No	

**SUBTOTAL (this page only)>** \_\_\_\_\_

**TOTAL SBE/MWBE Services Participation** \_\_\_\_\_

**TOTAL Non-MWBE/SBE Participation** \_\_\_\_\_

**TOTAL Percentage of Total Bid (Alternates & Change Orders)** \_\_\_\_\_

ATTACHMENT A

ented as Certified MWBEs/SBEs are certified according to requirements established in the Proposal &  
 A copy of the certification and signed Letter of Intent must be attached for each MWBE/SBE. List must  
 ivity firms.



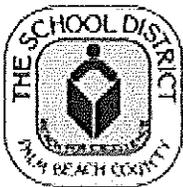

THE SCHOOL DISTRICT OF PALM BEACH COUNTY  
OFFICE OF DIVERSITY IN BUSINESS PRACTICES

# Participation Letter of Intent

Minority/Women Business Enterprise (M/WBE)    Small Business Enterprise (SBE)

Submit completed form to the Senior Project Administrator (SPA). Direct all questions to (561) 434-8508.  
**Form must be submitted to Demandstar.com**

BID/RFP or Project Name \_\_\_\_\_

BID/RFP or Project # \_\_\_\_\_

Name of Bidder/Construction Manager \_\_\_\_\_

The undersigned intends to perform work with the above project as (check one):

- Individual    Partnership    Corporation    Joint Venture\*

*\* If a joint venture, attach letterhead or other documentation proving relationship.*

The undersigned intends to perform work with the above project as (check one):

- Subcontractor    Subconsultant    Manufacturer    Supplier

The undersigned is:  Certified with the School District of Palm Beach County M/WBE Coordinator

Certified with the State of Florida, Department of General Services (Provisional)

The undersigned is: (MWBE must check one in column 1 and column 2; Column 2. completed by both MWBE or SBE; Column 3 completed by MWBE or SBE if applicable)

**Column 1 (MWBE ONLY)**

**Column 2 (MWBE ONLY)**

**Column 3**

- African American    Native American    Female    Physically Impaired  
 Asian American    American    Male  
 Hispanic American

**PARTICIPATION** The undersigned intends to perform the following work in connection with the above project:

Item No.	Division No.	Contract (Trade) Items (Description/Division)	Amount

If the undersigned intends to sub-contract any portion of this subcontract to a non-certified M/WBE or SBE subcontractor, the amount of any such subcontract must be stated \$ \_\_\_\_\_

Name of M/WBE or SBE Subcontracting Firm \_\_\_\_\_

Name and Position (type or print) \_\_\_\_\_

**INTERNAL USE ONLY - ROUTING DISPOSITION**  
All executed originals of the form must be submitted to the  
Office of Diversity in Business Practices  
3300 Forest Hill Blvd., A-106, West Palm Beach, FL 33406-5813

\_\_\_\_\_  
Signature

\_\_\_\_\_  
Date

**THE SCHOOL DISTRICT OF PALM BEACH COUNTY  
PURCHASING DEPARTMENT  
3300 Forest Hill Boulevard, Suite A-323  
West Palm Beach, FL 33406-5813**

**INVITATION TO BID  
15C-32B  
Bidder Acknowledgement**

**Vendor Name:** Superior Park Systems, Inc.

**Vendor Mailing Address:**

1418 Scott Street, Hollywood, FL 33020

**E-Mail Address:** Mitch@superiorparksystems.com

**Area Code / Telephone Number:** 954-445-7000

**Toll-Free Telephone Number:**

**Fax Number:** 954-921-9663

**Web Address:**

**FEID No. or SS #:** 52-2220662

**Delivery 30 - 45 calendar days after receipt of order:**

**ANTI-COLLUSION**

By electronically submitting your bid, the bidder certifies that they have not divulged, discussed or compared their bid with other bidders and have not colluded with any other bidder or parties to a bid whatever. No premiums, rebates or gratuities permitted either with, prior to, or after any delivery of material. Any such violation will result in the cancellation and/or return of materials (as applicable) and the removal from the bid lists for the School District of Palm Beach County, Florida and I hereby certify that I have read and understand the requirements of this Invitation to Bid and that I am duly authorized to execute this offer document and any contract(s) and/or other transaction by award of this bid.

**BID CERTIFICATION**

I further certify that I have read the entire contents of this Invitation to Bid document and agree to full, complete and unconditional acceptance of the contents of this Invitation to Bid and all appendices and the contents of any Addendum released hereto. I further certify that by virtue of executing and returning this Bidder Acknowledgement Form, I am submitting the following information as this company's response.

Name of Representative Submitting Bid : Mitch Leitner

Title of Company Representative: President

Date: 5/26/2015

## 15C-32B – Bid Summary

<b>Item 1</b>	<b>Playground Equipment And Outdoor Fitness Equipment</b>	
	<u>Firm Percentage Discount</u> <ul style="list-style-type: none"> <li>• Will be deducted from the catalog list prices</li> <li>• Bidders must bid a single fixed percentage discount, ex. 12% is acceptable; 11.075% is not</li> <li>• The District will accept a discount of 0%.</li> </ul> <u>Freight Charges:</u> <ul style="list-style-type: none"> <li>• All freight charges are to be prepaid by successful bidders and added to the invoice</li> <li>• The School District will only pay actual freight charges</li> <li>• It is further agreed by all vendors signing this bid proposal that title to all items ordered, remain with the vendor until received and accepted by the School District</li> <li>• Vendor is required to file all claims for damages/shortages etc.</li> </ul>	
	<b>List the Playground Equipment Manufacturer(s) and the Outdoor Fitness Equipment Manufacturer(s) you represent</b>	<b>Fixed % Percentage Discount off List Price</b>
	Xccent Outdoor Fitness Equipment	0%
	Xccent Outdoor Playground Equipment	0%
	Recreation Creations Playground & Fitness Equipment	5%
	Kidstuff Playsystems Playground Equipment	5%
	Kidstuff Playsystems Fitness Equipment	5%
<b>Item 2.</b>	<b>Installation of Playground and Outdoor Fitness Equipment</b>	<b>Fixed Percentage</b>
	Cost will be based on a firm fixed percentage of the equipment cost (the total after discount has been taken but before freight has been added)	<b>75%</b>
<p>NOTE:</p> <p>If bidding to only supply Playground and/or Outdoor Fitness Equipment,</p> <ul style="list-style-type: none"> <li>• you must list your certified installer below</li> </ul> <p style="text-align: center;"><b>AND</b></p> <ul style="list-style-type: none"> <li>• Your certified installer must submit a bid for installation</li> </ul> <p style="text-align: center;"><b>AND</b></p> <ul style="list-style-type: none"> <li>• Your certified installer must be awarded a contract for installation in order for you to be awarded to provide playground and/or outdoor fitness equipment</li> </ul>		
<b>Playground and Outdoor Fitness Equipment Installer's Company Name (if other than self):</b>		<b>N/A</b>

<b>Item 3.</b>	<b>Poured In Place (PIP) Surfacing for Playgrounds and Outdoor Fitness Equipment</b>						
	<ul style="list-style-type: none"> <li>• Poured In Place (PIP) surfacing must be IPEMA Certified &amp; ADA compliant</li> <li>• Price must be stated per square foot and price must include all materials, adhesives or sub-bases</li> </ul>						
<b>List Manufacturer:</b>	Southeast Surfacing & Recreation, LLC						
Critical Fall Height	3'	4'	5'	6'	7'	8'	10'
<b>3a)</b>							
Size	<b>Cost Per Sq Ft</b>	<b>Cost Per Sq Ft</b>	<b>Cost Per Sq Ft</b>	<b>Cost Per Sq Ft</b>	<b>Cost Per Sq Ft</b>	<b>Cost Per Sq Ft</b>	<b>Cost Per Sq Ft</b>
Up to 1,000 Sq Ft	\$16.75	\$16.75	\$16.75	\$16.75	\$16.75	\$16.75	\$16.75
1,000 to 3,000 Sq Ft	\$16.75	\$16.75	\$16.75	\$16.75	\$16.75	\$16.75	\$16.75
Over 3,000 Sq Ft	\$16.75	\$16.75	\$16.75	\$16.75	\$16.75	\$16.75	\$16.75
<b>3b) Installation of PIP surfacing charge if it is not included in the prices above</b>						\$ <u>N/A</u> per Sq Ft	

<b>Item 4.</b>	<b>Artificial Turf installed on a playground (with fall protection)</b>						
	<ul style="list-style-type: none"> <li>• Must be IPEMA certified and ADA compliant</li> <li>• Price stated must be per square foot and price must include all materials, adhesives, etc.</li> </ul>						
<b>List Manufacturer:</b>	Forever Lawn, Inc.						
Critical Fall Height	3'	4'	5'	6'	7'	8'	10'
<b>4a) Cost Per Sq Ft</b>							
Size	<b>Cost Per Sq Ft</b>	<b>Cost Per Sq Ft</b>	<b>Cost Per Sq Ft</b>	<b>Cost Per Sq Ft</b>	<b>Cost Per Sq Ft</b>	<b>Cost Per Sq Ft</b>	<b>Cost Per Sq Ft</b>
Up to 1,000 Sq Ft	\$16.75	\$16.75	\$16.75	\$16.75	\$16.75	\$16.75	\$16.75
1,000 to 3,000 Sq Ft	\$16.75	\$16.75	\$16.75	\$16.75	\$16.75	\$16.75	\$16.75
Over 3,000 Sq Ft	\$16.75	\$16.75	\$16.75	\$16.75	\$16.75	\$16.75	\$16.75
<b>4b) Installation of Artificial Turf charge if it is not included in the prices above</b>						\$ <u>N/A</u> per Sq Ft	

<b>Item 5.</b>	<b>Artificial Turf – Provide and install where fall protection is NOT required</b>						
<b>List Manufacturer:</b>	Forever Lawn, Inc.						
<b>5a)</b>	Cost Per	Cost Per	Cost Per	Cost Per	Cost Per	Cost Per	Cost Per Sq
Size	Sq Ft	Sq Ft	Sq Ft	Sq Ft	Sq Ft	Sq Ft	Ft
Up to 1,000 Sq Ft	\$15.95	\$15.95	\$15.95	\$15.95	\$15.95	\$15.95	\$15.95
1,000 to 3,000 Sq Ft	\$15.95	\$15.95	\$15.95	\$15.95	\$15.95	\$15.95	\$15.95
Over 3,000 Sq Ft	\$15.95	\$15.95	\$15.95	\$15.95	\$15.95	\$15.95	\$15.95
<b>5b)</b>	<b>Installation of Artificial Turf <u>Without</u> fall protection fee if installation is not included in the prices above</b>						\$ <u>N/A</u> per Sq Ft

<b>Item 6.</b>	<b>Engineered Wood Fiber</b> Must comply with ASTM and be IPEMA certified Quotes will be requested when needed <b>Indicate if you can provide (Yes or No)</b>	<u>X</u> Yes or ___ No
<b>List the Manufacturer:</b>		Irvine Wood Recovery

<b><u>Site Preparation:</u></b>		
<ul style="list-style-type: none"> <li>• All bidders for installation must complete this section in order to be awarded as the pool of pre-qualified vendors for all projects under this bid</li> <li>• Provide firm prices for the following line items</li> <li>• Prices must be submitted in the same unit of measure as listed below:</li> </ul>		
<b>Item 7.</b>	Dig-out/ Excavation Price must include removal and disposal	\$ <u> 2.50 </u> per sq. ft.
<b>Item 8.</b>	Sand, clean & suitable for playgrounds Price must include delivery and placement	\$ <u> 40.00 </u> per cubic yard
<b>Item 9.</b>	Clean Fill Delivered and graded	\$ <u> 28.60 </u> per sq. ft.
<b>Item 10.</b>	Concrete – provide and install All concrete shall comply with DMS & Fl. Building Code Includes concrete for sidewalks There shall be no additional fee for getting the concrete to the site	
<b>10a.</b>	4" Wide X 12" Deep for PIP surfacing	\$ <u> 94.00 </u> per sq. ft.
<b>10b.</b>	6" Wide X 12" Deep for artificial turf	\$ <u> 72.00 </u> per sq. ft.
<b>Item 11.</b>	Recycled playcurb borders Provide and install	\$ <u> 39.00 </u> per linear ft.
<b>Item 12.</b>	Aluminum ADA handrails Provide and install	\$ <u> 39.00 </u> per linear ft.
<b>Item 13.</b>	Provide Utility Locates	\$ <u> 550.00 </u> each
<b>Item 14.</b>	Provide signed sealed engineered drawings	\$ <u> 2995.00 </u> per job

<b><u>Additional Site Preparation Items:</u></b>
<p>Vendors may be required to provide quotations for optional items such as, but not limited to:</p> <ul style="list-style-type: none"> <li>• removal and/or relocation of existing playground equipment</li> <li>• replacement parts for playground components</li> <li>• tree trimming or removal</li> <li>• excavation/demucking for sites where rock or muck is found</li> <li>• provide and lay sod in area surrounding playground where sand was (sod replacement for site restoration shall be done at no charge to the District)</li> </ul>

<p><b>Item 15</b></p>	<p><b><u>Repair, Recap and/or Replace Playground Surfacing</u></b>          Bidder wishes to be in the pool of pre-qualified vendors and be eligible to respond to Request For Quotes (RFQ) for projects to Repair, Recap and/or Replace Playground Surfacing</p> <p style="text-align: center;"><b>Mark an "X" in the space provided</b></p>	<p style="text-align: center;"><u> X </u> YES</p>
-----------------------	---	---

<p><b>Item 16</b></p>	<p><b><u>Fabric Shade Structures :</u></b>          This will establish a pool of pre-qualified vendors to furnish and install fabric shade structures as requested in accordance with the terms, specifications, District Master Specs and conditions set forth in this bid</p> <p><b><i>To be in the pool of pre-qualified vendors and be eligible to respond to Request For Quotes (RFQ) for Fabric Shade Structures, you must mark an "X" in the box by "YES"</i></b></p>
-----------------------	---

NOTE:

If bidding to only supply Shade Structures

- you must list your certified installer below
- AND**
- Your certified installer must submit a bid for installation
- AND**
- Your certified installer must be awarded a contract to install this item in order for you to be awarded for this item

<p><b>Item 16</b></p>	<p style="text-align: center;"><b><u>Provide Shade Structures</u></b></p>	<p style="text-align: center;"><u> X </u> YES</p>	<p style="text-align: center;"><u>   </u> NO</p>
-----------------------	---	---	--

<p><b>Manufacturer:</b></p>	<p style="text-align: center;">Shade Systems, Inc.</p>
-----------------------------	--

<p><b>Installer if other than self:</b></p>	
---	--

<p><b>Item 17.</b></p> <p><b><u>Install Shade Structure</u></b></p>	<p style="text-align: center;"><u> X </u> YES</p>	<p style="text-align: center;"><u>   </u> NO</p>
---	---	--

<p><b>Item 18. <u>Provide Fitness Trails (equipment/stations &amp; surfacing)</u></b></p> <p>This will establish a pool of pre-qualified vendors to furnish and install Fitness Trails as requested in accordance with the terms, specifications and conditions set forth in this bid and all applicable codes and standards.</p> <p><b><i>To be in the pool of pre-qualified vendors and be eligible to respond to Request For Quotes (RFQ) for Fitness Trails, you must mark an "X" in the box by "YES"</i></b></p>		
<p>NOTE:</p> <p>If bidding to only supply Fitness Trail Equipment/Stations,</p> <ul style="list-style-type: none"> <li>• you must list your certified installer below</li> </ul> <p style="text-align: center;"><b>AND</b></p> <ul style="list-style-type: none"> <li>• Your certified installer must submit a bid for installation</li> </ul> <p style="text-align: center;"><b>AND</b></p> <ul style="list-style-type: none"> <li>• Your certified installer must be awarded a contract for the installation in order for you to be awarded to provide Fitness Trail Equipment/Stations</li> </ul>		
<b>Item 18</b>	<b>Provide Fitness Trail Equipment</b>	<input checked="" type="checkbox"/> YES <input type="checkbox"/> NO
<b>Manufacturer:</b>	Xccent Fitness Equipment, Recreation Creations, and Kidstuff Fitness	
<b>Installer if other than self:</b>		
<b>Item 19.</b>	<b><u>Install Fitness Trails and Surfacing</u></b>	<input checked="" type="checkbox"/> YES <input type="checkbox"/> NO

<p><b>Item 20. Replacement Parts for Playground or outdoor fitness equipment and supplies such as sealer for poured in place surfacing:</b>                  List the Playground Equipment Manufacturer(s) and the Outdoor Fitness Equipment Manufacturer(s) you are authorized to sell replacement parts or supplies for and provide a firm percentage discount to be taken off list price or mark "Yes" to provide quotes if you cannot give a single fixed discount off list price (Refer to Bid Specifications)</p>	<p><b>Fixed Percentage Discount off List Price</b></p>	<p><b>Cannot give firm discount but will provide quotes when requested (Mark "Yes")</b></p>
<p>Xccent Playground Equipment</p>	<p>5%</p>	
<p>Xccent Fitness Equipment</p>	<p>5%</p>	
<p>Recreation Creation Fitness Equipment</p>	<p>5%</p>	
<p>Recreation Creation Playground Equipment</p>	<p>5%</p>	
<p>Southeast Surfacing &amp; Recreation - Sealer &amp; All Other Supplies Associated with PIP Rubber</p>	<p>5%</p>	
<p>Delivery Business Days After Receipt of Order (ARO):</p>	<p>30 - 45 business days</p>	
<p>Address of facility where parts will be shipped from:                  1418 Scott Street, Hollywood, FL 33020</p>		

<p><b>Item 21</b></p>	<p><b><u>Recoat existing PVC playground equipment decks</u></b>                  Provide on-site service to restore/renew decks that are worn and/or have coating that is peeling                  Includes cleaning, priming and recoating in compliance with all applicable standards and codes                  Bidder wishes to be in the pool of pre-qualified vendors and be eligible to respond to Request For Quotes (RFQ) for single jobs or larger projects to  <b>Mark an "X" in the space provided</b></p>	<p><u> X </u> YES</p>
-----------------------	--	-----------------------

<p><b>Vendor Name:</b></p>	<p>Superior Park Systems, Inc.</p>
----------------------------	------------------------------------

**This form must be downloaded, completed and uploaded to DemandStar with your bid response**

SCHOOL DISTRICT OF PALM BEACH COUNTY  
PURCHASING DEPARTMENT

**Bid 15C-32B- REFERENCES**

**Vendor Name:** Superior Park Systems, Inc.

This information will be used in the evaluation of this bid.

- Complete the information below
- Notify each reference that we will be contacting them by email and their response will be used in evaluating your company
- School District or Governmental agencies are preferred references
- References shall not be for work performed more than 3 years ago
- You may not list the School District of Palm Beach County as more than one reference

State the type of work you did for each reference from this list of options (list all that apply):

- Provided playground equipment**
- Installed playground or outdoor fitness equipment**
- Provided & installed PIP surfacing**
- Provided & installed artificial turf**
- Provided fabric shade structure**
- Installed fabric shade structure**
- Provided fitness trails**
- Installed fitness trails**

<b>Reference 1</b>	
<b>School District, Governmental Agency or Company:</b>	City of West Park
<b>Contact Person:</b>	Cesar Garcia
<b>Email:</b>	Cgarcia@cityofwestpark.org
<b>Phone #:</b>	954-822-1829
<b>Type of work (choose from list above)</b>	Provided playground equipment Installed playground or outdoor fitness equipment Provided & installed artificial turf Provided fabric shade structure Installed fabric shade structure Provided fitness trails Installed fitness trails
<b>Date work was completed</b>	February 2013 - May 2015

**Reference 2**

<b>School District, Governmental Agency or Company:</b>	City of Lauderhill
<b>Contact Person:</b>	Scott Newton
<b>Email:</b>	Snewton@lauderhill-fl.gov
<b>Phone #:</b>	954-232-8691
<b>Type of work (choose from list above)</b>	<p>Provided playground equipment          Installed playground or outdoor fitness equipment          Provided &amp; installed artificial turf          Provided fabric shade structure</p>
<b>Date work was completed</b>	October 2012 - March 2015

**Reference 3**

<b>School District, Governmental Agency or Company:</b>	City of North Miami
<b>Contact Person:</b>	Derrick Corker
<b>Email:</b>	dcorker@northmiamigl.gov
<b>Phone #:</b>	954-288-5586
<b>Type of work (choose from list above)</b>	<p>Provided playground equipment          Installed playground or outdoor fitness equipment          Provided &amp; installed PIP surfacing          Provided &amp; installed artificial turf          Provided fabric shade structure          Installed fabric shade structure          Provided fitness trails          Installed fitness trails</p>
<b>Date work was completed</b>	October 2014 - May 2015

**Reference 4**

<b>School District, Governmental Agency or Company:</b>	City of Homestead
<b>Contact Person:</b>	Dennis Maytan
<b>Email:</b>	dmaytan@cityofhomestead.com
<b>Phone #:</b>	305-216-7533
<b>Type of work (choose from list above)</b>	<p>Provided playground equipment          Installed playground or outdoor fitness equipment          Provided &amp; installed artificial turf          Provided fabric shade structure          Installed fabric shade structure</p>
<b>Date work was completed</b>	October 2012 - February 2014

**Reference 5**

<b>School District, Governmental Agency or Company:</b>	City of Weston
<b>Contact Person:</b>	Don Decker
<b>Email:</b>	ddecker@westonfl.org
<b>Phone #:</b>	954-389-4321
<b>Type of work (choose from list above)</b>	Provided playground equipment Installed playground or outdoor fitness equipment Provided & installed PIP surfacing Provided & installed artificial turf Provided fabric shade structure Installed fabric shade structure
<b>Date work was completed</b>	November 2012 - February 2015

**This form must be downloaded, completed and uploaded to DemandStar with your bid response**

## SCHOOL DISTRICT OF PALM BEACH COUNTY

## PURCHASING DEPARTMENT

**DEBARMENT CERTIFICATION****CERTIFICATION REGARDING DEBARMENT, SUSPENSION,  
INELIGIBILITY AND VOLUNTARY EXCLUSION  
LOWER TIER COVERED TRANSACTIONS**

This certification is required by the regulations implementing Executive Order 12549, Debarment and Suspension, 7 CFR Part 3017, Section 3017.510, Participants' responsibilities. The regulations were published as Part IV of the January 30, 1989, Federal Register (pages 4722-4733). Copies of the regulations may be obtained by contacting the Department of Agriculture agency with which this transaction originated. (Before Completing Certification, Read Instructions on Following Page)

- (1) The prospective lower tier participant certifies, by submission of this proposal, that neither it nor its principals is presently debarred, suspended, proposed for debarment, declared ineligible, or voluntarily excluded from participation in this transaction by an Federal department or agency.
- (2) Where the prospective lower tier participant is unable to certify to any of the statements in this certification, such prospective participants shall attach an explanation to this proposal.

Organization Name: Superior Park Systems, Inc.

Solicitation Number or Project Name: Bid 15C-32B

Name of Authorized Representative: Mitch Leitner

Title of Representative: President

Date: 5/26/2015

**INSTRUCTION CERTIFICATIONS**

1. By electronic submission of this form the prospective lower tier participant is providing the certification set out on the reverse side in accordance with these instructions.
2. The certification in this clause is a material representation of fact upon reliance was placed when this transaction was entered into. If it is later determined that the prospective lower tier participant knowingly rendered an erroneous certification, in addition to other remedies available to the Federal Government, the department or agency with which this transaction originated may pursue available remedies, including suspension and/or debarment.
3. The prospective lower tier participant shall provide immediate written notice to the person to which this proposal is submitted if at any time the prospective lower tier participant learns that its certification was erroneous when submitted or has become erroneous by reason of changed circumstances.
4. The terms "covered transaction," "debarred," "suspended," "ineligible," "lower tier covered transaction," "participant," "person," "primary covered transaction," "principal," "proposal," "voluntarily excluded," as used in this clause, have the meanings set out in the Definitions and Coverage section so rules implementing Executive Order 12549. You may contact the person to which this proposal is submitted for assistance in obtaining a copy of those regulations.
5. The prospective lower tier participant agrees by submitting this form that, should the proposed covered transaction be entered into, it shall not knowingly enter into any lower tier covered transaction with a person who is debarred, suspended, declared ineligible, or voluntarily excluded from participation in this covered transaction, unless authorized by the department or agency with which this transaction originated.
6. The prospective lower tier participant further agrees by submitting this form that it will include this clause titled, "Certification Regarding Debarment, Suspension, Ineligibility and Voluntary Exclusion - Lower Tier Covered Transactions," without modification, in all lower tier covered transactions and in all solicitations for lower tier covered transactions.
7. A participant in a covered transaction may rely upon a certification of a prospective participant in a lower tier covered transaction that it is not debarred, suspended, ineligible, or voluntarily excluded from the covered transaction, unless it knows that the certification is erroneous. A participant may decide the method and frequency by which it determines the eligibility of its principals. Each participant may, but is not required to, check the Non-procurement List.
8. Nothing contained in the foregoing shall be construed to require establishment of a system of records in order to render in good faith the certification required by this clause. The knowledge and information of a participant is not required to exceed that which is normally possessed by a prudent person in the ordinary course of business dealings.
9. Except for transactions authorized under paragraph 5 of these instructions, if a participant in covered transaction knowingly enters into a lower tier covered transaction with a person who is suspended, debarred, ineligible, or voluntarily excluded from participation in this transaction, in addition to other remedies available to the Federal Government, the department or agency with which this transaction originated may pursue available remedies, including suspension and/or debarment.

SCHOOL DISTRICT OF PALM BEACH COUNTY  
PURCHASING DEPARTMENT

**EARLY PAYMENT TERMS**

<p><b>BID NAME/NUMBER:</b> <u>15C-32B</u></p> <p><b>VENDOR NAME:</b> <u>Superior Park Systems, Inc.</u></p>
---

If vendor chooses not to participate in Early Payment Terms, please acknowledge by placing N/A here → N/A.

<p><b>EARLY PAYMENT:</b> Specify terms and discount for early payment. Check which terms you will be willing to provide for the duration of this contract to the School District.</p>
<p><input type="radio"/> 0.5% 10 net 30 *</p>
<p><input type="radio"/> 0.75% 5 net 30 *</p>

\* Upon receipt of invoice by the School District of Palm Beach County Accounts Payable Department.

**Note:** Updating to these terms will affect all of your District payments. If you choose to revise these terms at a later date, the terms will affect all of your payments from the District.

**School District of Palm Beach County**  
**MINORITY CERTIFICATION INFORMATION**

**Bid 15C-32B**

\* Check here if N/A:   N/A  

Form **must be submitted** with your bid response to **Demandstar.com**

Minority Certification applications are available through the Minority Business Enterprise located at: Office of Diversity in Business Practices School District of Palm Beach County 3300 Forest Hill Boulevard, Suite A-106 West Palm Beach, FL 33406-5871 Phone: (561) 434-8508 <a href="http://www.palmbeachschools.org/mwbe/">http://www.palmbeachschools.org/mwbe/</a>	
<b>Are you a minority vendor certified by:</b> (Check if appropriate) Palm Beach County School District _____ State of Florida _____ If yes, expiration date _____ Minority Classification _____	
If you are not a certified minority vendor and intend to sub-contract with a certified minority firm(s), please list the vendors and the estimated dollar value below:	
<b><u>Vendor</u></b>	<b><u>Estimated Dollar Value</u></b>
_____	\$ _____
_____	\$ _____
_____	\$ _____

Reminder: *Download all documents, complete them and **save as a single PDF document** and re-upload them to DemandStar.*



**THE SCHOOL DISTRICT OF PALM BEACH COUNTY**  
**Drug-Free Workplace Certification**

Preference must be given to vendors submitting a certification with their bid/proposal certifying they have a drug-free workplace in accordance with Section 287.087, Florida Statutes. This requirement affects all public entities of the State and becomes effective January 1, 1991. The special condition is as follows:

**IDENTICAL TIE BIDS** - Preference shall be given to businesses with drug-free workplace programs. Whenever two or more bids which are equal with respect to price, quality, and service are received by the State or by any political subdivision for the procurement of commodities or contractual services, a bid received from a business that certifies that it has implemented a drug-free workplace program shall be given preference in the award process. Established procedures for processing tie bids will be followed if none of the tied vendors have a drug-free workplace program, a business shall:

- 1) Publish a statement notifying employees that the unlawful manufacture, distribution, dispensing, possession, or use of a controlled substance is prohibited in the workplace and specifying the actions that will be taken against employees for violations of such prohibition.
- 2) Inform employees about the dangers of drug abuse in the workplace, the business's policy of maintaining a drug-free workplace, any available drug counseling, rehabilitation, and employee assistance programs, and the penalties that may be imposed upon employees for drug abuse violations.
- 3) Give each employee engaged in providing the commodities or contractual services that are under bid a copy of the statement specified in subsection (1).
- 4) In the statement specified in subsection (1), notify the employees that, as a condition of working on the commodities or contractual services that are under bid, the employee will abide by the terms of the statement and will notify the employer of any conviction of, or plea of guilty or nolo contendere to, any violation of chapter 893 or of any controlled substance law of the United States or any state, for a violation occurring in the workplace no later than five (5) days after such conviction.
- 5) Impose a sanction on, or require the satisfactory participation in a drug abuse assistance or rehabilitation program if such is available in the employee's community, by any employee who is so convicted.
- 6) Make a good faith effort to continue to maintain a drug-free workplace through implementation of this section.

As the person authorized to sign the statement, I certify that this firm complies fully with the above requirements.

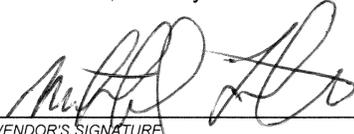
  
 \_\_\_\_\_  
 VENDOR'S SIGNATURE

5/26/2015

DATE

Superior Park Systems, Inc.

COMPANYNAME

**Must be executed and returned with attached bid at time of bid opening to be considered.**

**PROPOSER'S STATEMENT OF PRINCIPAL PLACE OF BUSINESS**  
*(Must be completed & submitted with each competitive solicitation)*

Name of Proposer: Superior Park Systems, Inc.

Identify the state in which the Proposer has its principal place of business: Florida

Proceed as follow: **IF** your principal place of business above is located within the State of Florida, the Proposer may sign below and attach to your solicitation. No further action is required. **IF** your principal place of business is outside of the State of Florida the following must be completed by an attorney and returned with your solicitation. Failure to comply shall be considered to be non-responsive to this solicitation.

**OPINION OF OUT-OF-STATE BIDDER'S ATTORNEY ON BIDDING PREFERENCES**  
*(To be completed by the Attorney for an Out-of-State Proposer)*

**NOTICE:** Section 287.084(2), Fla. Stat., provides that "a vendor whose principal place of business is outside this state must accompany any written bid, proposal, or reply documents with a written opinion of an attorney at law licensed to practice law in that foreign state, as to the preferences, if any or none, granted by the law of that state [or political subdivision thereof] to its own business entities whose principal places of business are in that foreign state in the letting of any or all public contracts." See also: Section 287.084(1), Fla. Stat.

**LEGAL OPINION ABOUT STATE BIDDING PREFERENCES**  
*(Please Select One)*

\_\_\_\_\_ The Proposer's principal place of business is in the State of \_\_\_\_\_ and it is my legal opinion that the laws of that state **do not grant a preference** in the letting of any or all public contracts to business entities whose principal places of business are in that state.

\_\_\_\_\_ The Proposer's principal place of business is in the State of \_\_\_\_\_ and it is my legal opinion that the laws of that state **grant the following preference(s)** in the letting of any or all public contracts to business entities whose principal places of business are in that state: [Please describe applicable preference(s) and identify applicable state law(s)]:

\_\_\_\_\_  
\_\_\_\_\_  
\_\_\_\_\_

**LEGAL OPINION ABOUT POLITICAL SUBDIVISION BIDDING PREFERENCES**  
*(Please Select One)*

\_\_\_\_\_ The Proposer's principal place of business is in the political subdivision of \_\_\_\_\_ and it is my legal opinion that the laws of that political subdivision **do not grant a preference** in the letting of any or all public contracts to business entities whose principal places of business are in that political subdivision.

\_\_\_\_\_ The Proposer's principal place of business is in the political subdivision of \_\_\_\_\_ and the laws of that political subdivision **grant the following preference(s)** in the letting of any or all public contracts to business entities whose principal places of business are in that political subdivision: [Please describe applicable preference(s) and identify applicable authority granting the preference(s)]:

\_\_\_\_\_  
\_\_\_\_\_  
\_\_\_\_\_

Signature of out-of-state Proposer's attorney: \_\_\_\_\_

Printed name of out-of-state Proposer's attorney: \_\_\_\_\_

Address of out-of-state bidder's attorney: \_\_\_\_\_

Telephone Number of out-of-state bidder's attorney: (\_\_\_\_) \_\_\_\_ - \_\_\_\_\_

Email address of out-of-state bidder's attorney: \_\_\_\_\_

Attorney's states of bar admission: \_\_\_\_\_

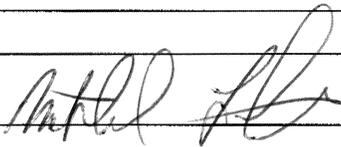
Proposer's Printed Name: Mitch Leitner Signature 

Company Name: Superior Park Systems, Inc.

**Bid 15C-32B**

**AREA REPRESENTATIVE**

Please list the contact for this bid

Vendor Name:	Superior Park Systems, Inc.
Area Representative:	Mitch Leitner
Email Address:	Mitch@superiorparksystems.com
Cell Phone Number:	954-445-7000
Office Number (With extension)	954-920-3352

**This form must be downloaded, completed and uploaded to DemandStar with your bid response**



THE SCHOOL DISTRICT OF PALM BEACH COUNTY  
**Beneficial Interest and Disclosure of Ownership Affidavit**

Bid No. 15C-32B Project No./ Title Playground Equipment, Outdoor Fitness Equipment, Surfacing, Fitness Trails, and Fabric Shade Structures

Corporate Name Superior Park Systems, Inc. Tax FEIN No. 52-2220662

Before me, the undersigned authority, personally appeared, Mitch Leitner, ("Corporate Representative") this 26 day of May, 2015, who, first being duly sworn, as required by law, subject to the penalties prescribed for perjury, deposes and says:

- 1) Corporate Representative has read the contents of this Affidavit, has actual knowledge of the facts contained herein, and states that the facts contained herein are true, correct, and complete.
- 2) The following is a list of every "person" (as defined in Section 1.01(3), Florida Statutes to include individuals, children firms, associates, joint adventures, partnerships, estates, trusts, business trusts, syndicates, fiduciaries, corporations and all other groups and combinations) holding 5% or more of the beneficial interest in the disclosing entity: (If more space is needed, attach separate sheet)

A. Persons or corporate entities owning 5% or more:

Name	Address	Percentage
Mitch Leitner	1418 Scott Street, Hollywood, FL 33020	100%

B. Persons or corporate entities who hold by proxy the voting power of 5% or more:

Name	Address	Percentage
Mitch Leitner	1418 Scott Street, Hollywood, FL 33020	100%

C. Stock held for others and for whom held:

1. Name / 2. From Whom Held	Address	Percentage
1. None	N/A	N/A
2.		
1.		
2.		
1.		
2.		

CORPORATE REPRESENTATIVE

By: Mitch Leitner

SWORN TO and subscribed before me this 27<sup>th</sup> day of May, 2015, by Mitch Leitner 6356-557-67-083-0 Such person(s) (Notary Public must check applicable box).

is/are personally known to me.  produced a current driver license(s).  produced \_\_\_\_\_ as identification.

(NOTARY PUBLIC SEAL)



**Stephanie Michelle Verrier**  
 COMMISSION # FF194554  
 EXPIRES: February 1, 2019  
 WWW.AARONNOTARY.COM

Notary Public  
Stephanie Verrier  
 (Print, Type or Stamp Name of Notary Public)

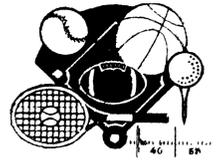

# SUPERIOR PARK SYSTEMS, INC.

"A CERTIFIED LOCAL MBE/SBE OWNED BUSINESS #22214"  
"For All of Your Parks and Recreational Needs"

May 26, 2015

---

## Organization Profile

**Name of the Organization:** Superior Park Systems, Inc.

**Address:** 1418 Scott Street, Hollywood, FL 33004

**Contact:** Mitch Leitner, President

**E-Mail:** [Mitch@superiorparksystems.com](mailto:Mitch@superiorparksystems.com)

**Contact Phone:** 954-445-7000

**Years In Business:** 15 Years

**Number of Locations:** 1 Location

**Company Vision Statement:** The mission of Superior Park Systems, Inc. is to provide quality play equipment, facilities and services to meet the physical educational and extracurricular activity needs of students at all levels of our public school system at the lowest cost possible and best warranty available.

**Succinct History:** Superior Park Systems, Inc was formed in March 2000 and has since grown to be one of the largest playground and fitness equipment suppliers for South Florida. We have a diverse portfolio of cities, areas of expertise and knowledge of playground and fitness equipment. Our passion has always been to provide the best possible service and equipment at an affordable price with an outstanding warranty.

---

**Mobile (954) 445-7000 Office (954) 920-3352 Fax (954) 921-9563**  
**1418 Scott St. Hollywood, FL 33020**  
**E-Mail - [mitch@superiorparksystems.com](mailto:mitch@superiorparksystems.com)**



CITY OF HOLLYWOOD  
TREASURY SERVICES DIVISION  
LOCAL BUSINESS TAX RECEIPTING  
2600 HOLLYWOOD BLVD, ROOM 103  
HOLLYWOOD, FL 33020

SUPERIOR PARK SYSTEMS  
1418 SCOTT ST  
HOLLYWOOD FL 33020

4752 21145



**CITY OF HOLLYWOOD LOCAL BUSINESS TAX RECEIPT**

PRINT DATE: 9/15/14

THIS IS YOUR LOCAL BUSINESS TAX RECEIPT. PLEASE DETACH AND POST IN A CONSPICUOUS PLACE AT THE BUSINESS LOCATION. PLEASE DO NOT REMIT ANY PAYMENT. **THIS IS NOT A BILL.**

<b>Business Name:</b>	SUPERIOR PARK SYSTEMS
<b>Business Location:</b>	1418 SCOTT ST
<b>Business Class:</b>	OFFICE
<b>Tax Basis:</b>	1 WORKER (OWNER)
<b>Receipt Number:</b>	15 00042291
<b>Receipt Year:</b>	10/01/14
<b>Expiration Date:</b>	09/30/15

<b>NEW CHARGES:</b> (Itemized Below)	61.00
Base Fee	61.00
Additional Charges:	
	.00
	.00

**Comments:**

<b>TOTAL NEW CHARGES:</b>	61.00
<b>Penalty Amount:</b>	.00
<b>Previous Balance Due:</b>	.00
<b>TOTAL AMOUNT PAID:</b>	61.00

PURSUANT TO STATE LAW, THE LOCAL BUSINESS TAX IS LEVIED ON THE PRIVILEGE OF DOING BUSINESS WITHIN A CITY'S LIMITS, AND IS NON-REGULATORY IN NATURE. ISSUANCE OF A LOCAL BUSINESS TAX RECEIPT BY THE CITY OF HOLLYWOOD DOES NOT MEAN THAT THE CITY HAS DETERMINED THAT THE EXISTING OR PROPOSED USE OF A LOCATION IS LAWFUL. ISSUANCE OF A LOCAL BUSINESS TAX RECEIPT DOES NOT LEGALIZE OR CONDONE THE NATURE OF THE BUSINESS BEING CONDUCTED IF CONTRARY TO ANY LOCAL, STATE OR FEDERAL LAWS OR REGULATIONS.

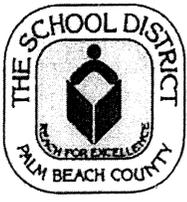

THE SCHOOL DISTRICT  
OF PALM BEACH COUNTY, FLORIDA

SHARON SWAN  
DIRECTOR

MICHAEL J. BURKE  
CHIEF OPERATING OFFICER

Purchasing Department  
3300 Forest Hill Boulevard, Suite A-323  
West Palm Beach, FL 33406-5813  
Phone: (561) 434-8214 Fax: (561) 963-3823  
[www.palmbeachschools.org/purchasing](http://www.palmbeachschools.org/purchasing)

August 25, 2015

Superior Park Systems, Inc.  
Mr. Mitch Leitner, President  
1418 Scott Street  
Hollywood, FL 33020  
[mitch@superiorparksystems.com](mailto:mitch@superiorparksystems.com)

Subject: Letter of Agreement  
Bid Number: 15C-32B  
Title: Term Contract for Playground Equipment, Outdoor Fitness Equipment, Surfacing, Fitness Trails and Fabric Shade Structures  
Contract Term: August 20, 2015 through August 19, 2020

Dear Mr. Leitner:

This is to advise you that the School District of Palm Beach County, Florida, has accepted your offer to furnish playground equipment, outdoor equipment, surfacing, fitness trails and fabric shade structures. This acceptance is subject to compliance with bid specifications, terms and conditions, all pertinent laws of the State of Florida and instructions as determined by the General Counsel for the School District.

A Certificate of Insurance as per special condition "S", "Insurance Requirements" must be emailed to [insurancecertificate@palmbeachschools.org](mailto:insurancecertificate@palmbeachschools.org), or faxed to 561-963-3823 within seven (7) days of this notification. Your insurance company is required to have the **School Board of Palm Beach County, Florida, NAMED AS AN ADDITIONAL INSURED**. No work shall commence until we receive the Certificate of Insurance and it must reference the above Bid Number. Please be sure to advise your insurance carrier.

Purchase orders may be issued to cover the playground equipment, outdoor equipment, surfacing, fitness trails and fabric shade structures as the need arises and will be your notification to proceed with fulfilling the School District's request. Shipment without proper authorization may result in nonpayment.

If you have any questions, please do not hesitate to call my office at **561-434-8310**. Thank you for your bid and we are looking forward to doing business with you and your company.

Sincerely,

Sharon Swan, C.P.M., Director  
Purchasing Department

CC: bid file  
Karen Adducci, Purchasing Agent

---

The School District of Palm Beach County, Florida  
A Top-Rated District by the Florida Department of Education Since 2005  
*An Equal Education Opportunity Provider and Employer*